

# Lt665R

6.0 Megapixel, High Sensitivity, CCD  
Camera with High-Speed USB 3.0



## High Resolution, Low Noise CCD Imaging

The Lt665R is Lumenera's latest innovative, high performance USB 3.0 CCD camera based on the solid design of the Lt365R. Easy to use, the Lt665R builds on leading edge EXview HAD II technology to deliver high quality imaging and high sensitivity in a compact camera rich in features. Low noise electronics ensure clear and sharp images rendering details with amazing accuracy. Its superior responsiveness position it as a good choice for Near-Infrared (NIR) imaging. This industrial-grade camera is ideally suited for a variety of applications including ophthalmology, traffic, tolling, surveillance, high-speed inspection and machine vision. A scientific-grade variant is available for the most demanding life science applications. The Lt665R can also be customized to suit OEM designs.

## High Quality Images at High Speed

The Lt665R was created for speed using the latest USB 3.0 technology to deliver the fastest image delivery possible from the Sony ICX694 sensor at its highest resolution. Image captures can be synchronized using either a hardware or software trigger. FPGA-enabled performance, complemented by 128 MB of onboard memory for frame buffering, ensures dependable and reliable image delivery even in the most demanding machine vision systems. Unlike some competitive cameras, the Lt665R buffer technology delivers all frames at full speed and max resolution without introducing latency.

## Plug-and-Play with No Framegrabber

The compact, robust design of this camera, measuring 43 x 43 x 65 mm, allows for easy integration into tight spaces and systems. The locking USB 3.0 cabling and digital interface ensure a simple plug-and-play installation. No framegrabber is required. Simplified I/O cabling is provided through a locking Hirose connector supporting external power input along with 1 optically isolated output, 1 optically isolated input and 2 configurable I/O ports.

## Maximize Camera Performance Within Your Own Application

The Lumenera Camera SDK provides a full suite of features and functions that allow you to maximize the camera's performance within your own vision application with minimal work. The SDK is compatible with all of our USB and GigE-based cameras. Microsoft DirectX/DirectShow, Windows API and .NET API interfaces are provided, allowing you the choice of application development environments from C/C++ to VB.NET or C#.NET. Over 50 sample applications, associated source code and comprehensive documentation included.

## Superior Technical Assistance Center

All Lumenera cameras, SDK and API are supported by an experienced team of technical support and imaging experts widely acclaimed in the industry. We understand your imaging needs and are here to help you get the most out of your camera.

## Features

- Industry leading Sony EXview HAD II sensor technology
- Fastest USB 3.0 camera using the ICX694 sensor: 27 fps at full resolution
- Color or monochrome CCD sensor with 1" optical format providing a resolution of 2752 x 2192 using 4.54 x 4.54  $\mu\text{m}$  pixels
- High-speed USB 3.0 interface for fastest image delivery and simplified connectivity
- Compact, robust form factor measuring 43 x 43 x 65 mm with 4 mounting points on all 4 sides and 1 tripod (1/4"-20) mount
- Locking industrial micro USB and Hirose GPIO connector for power and control of peripherals and synchronization of lighting
- 4 GPIO: 1 optically isolated output, 1 optically isolated input and 2 configurable I/O ports
- 128 MB RAM frame buffer
- Simplified cabling – video and full camera control over a single locking micro USB 3.0 cable
- Region of Interest (ROI) option to provide higher frame rates
- Selectable 8 or 14-bit pixel data
- Selectable tap readout to match sensor performance to your application
- Multiple data rates supported, each optimized for lowest noise performance
- FCC Class B, CE Certified
- DirectShow compatible
- Software compatible with Windows 8, 7, XP, Vista, 32 and 64-bit operating systems
- Complete Windows and Linux SDKs available
- Four (4) year warranty



Color Quantum Efficiency Curves

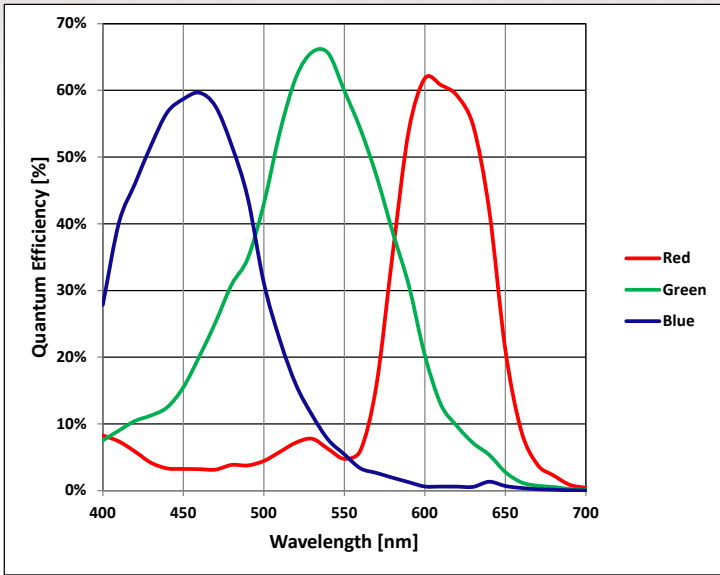

Monochrome Quantum Efficiency Curve

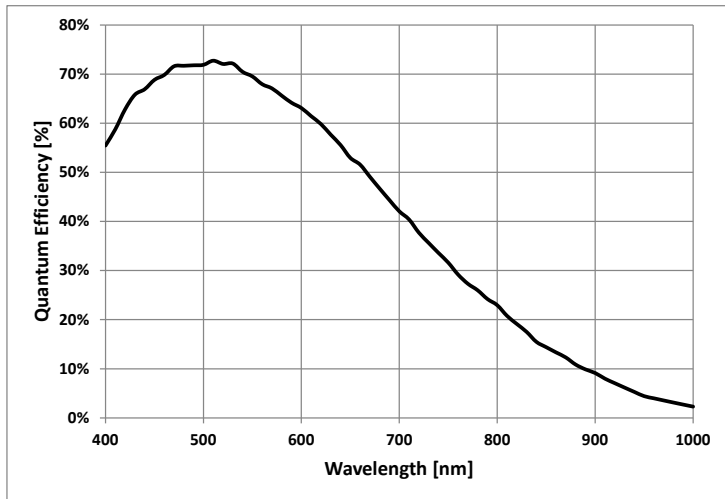

Sensor Specifications	
Image Sensor	Sony ICX694, CCD, color or monochrome
Optical Format	1"
Active Area	Diagonal 15.99 mm
Pixel Size	4.54 x 4.54 µm
Resolution	2752 x 2192 pixels
Region of Interest Control	Any multiple of 16 x 16 (quad tap mode)
Camera Specifications	
Max Frame Rate	27 fps at 2752 x 2192, 46 fps with 2x2 binning
Bit Depth	8 or 14-bit
Binning Modes	2 x 2, 4 x 4, 8 x 8 (3 x 3 mono only)
Exposure Control	Manual and automatic control
Exposure Range	3 µs to 71 min (snapshot) 31 µs to 1.79 s (video)
Gain Control	Manual and automatic control
Gain Range	0.8 to 56 x
White Balance	Manual and automatic control
Trigger Modes	Hardware and software triggerable
Camera Characteristics	
Sensitivity	Mono: 5.2 DN/(nJ/cm <sup>2</sup> ), Color: 4.3 DN/(nJ/cm <sup>2</sup> ) (Global and channel gains at unity)
Dynamic Range	68.8 dB
Full Well Capacity	16,500 e-
Quantum Efficiency	73% (Mono), 66% (Color)
Read Noise	6 e- (Quad-Tap Mode)
Dark Current Noise	<1 e-/s (at 22 °C ambient, 41 °C internal)
Mechanical Specifications	
Data Interface	USB 3.0, micro locking connector
General Purpose I/O	Locking Hirose MXR-8R-8SA(71)
Lens Mount	C-Mount
Dimensions	43 x 43 x 65 mm
Mass	175 g
Operating Temperature	0 to 50 °C
Storage Temperature	-30 to 70 °C
Operating Humidity	5 to 95 %, non-condensing
Shock / Vibration	50 G shock / 5 G (2 to 200 Hz) vibration
Camera Software	
Operating Systems	Windows XP, Windows Vista, Windows 7, Windows 8, 32 and 64-bit operating systems
Software Interfaces	DirectShow
Power and Emissions	
Power Consumption	6.0 W
Power Requirement	USB Y cable or, La2000PK or La2000PIOK power kit to provide 5 V DC, 1.5 A, power through GPIO
Emissions Compliances	FCC Class B, CE Certified
Hazardous Materials	RoHS, WEEE Compliant
Warranty	Four (4) year
Ordering Options	
Lt665RM	6.0 MP Monochrome Camera
Lt665RC	6.0 MP Color Camera
La2000PK	Power Supply via GPIO connector (power only)
La2000PIOK	Power Supply with GPIO cable (leads + power)
LuCAMSW-DVD	DVD with user application software, camera device drivers and documentation
LuSDK	Software Developer's Kit (Web Download)
Customization Options	
-SCI	Scientific grade
-WOIR	Plain glass within lens mount



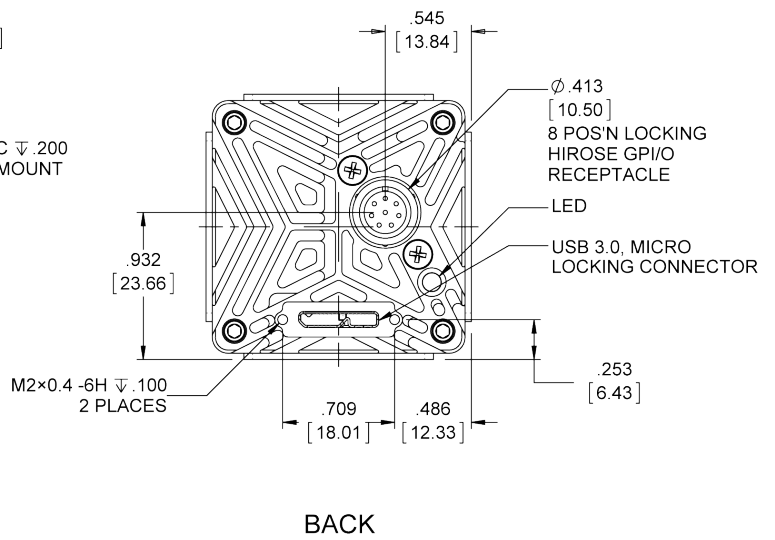
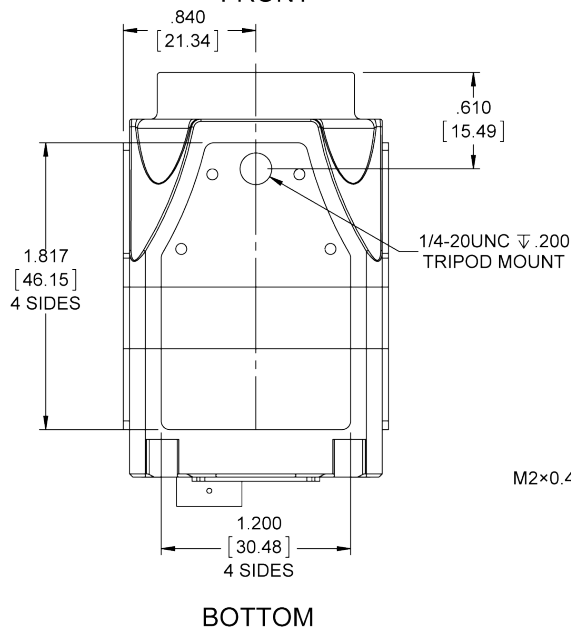
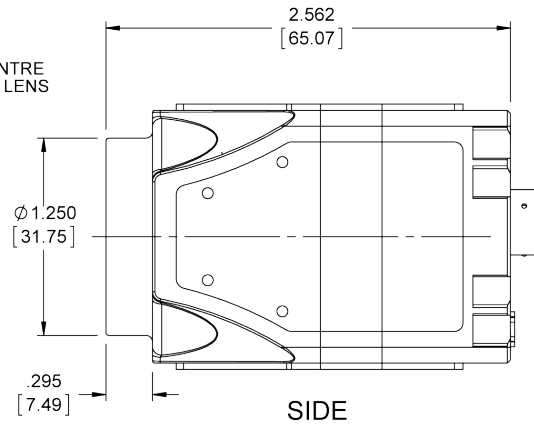
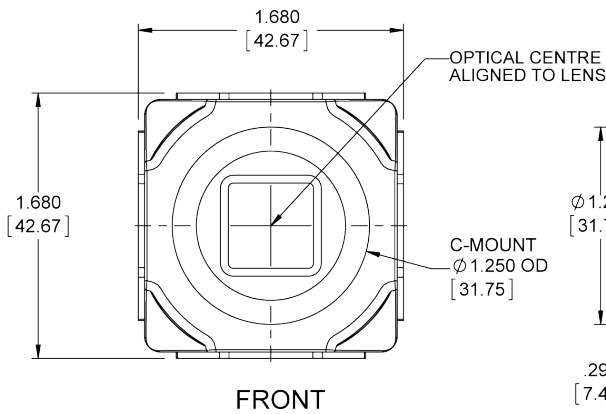
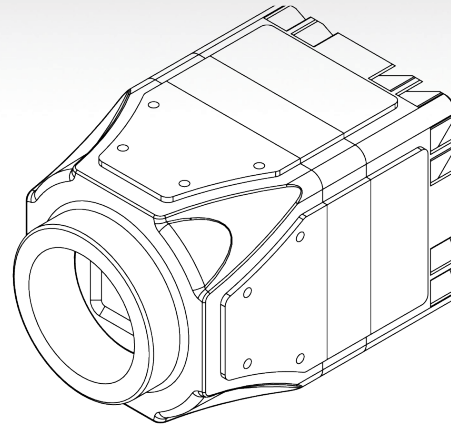
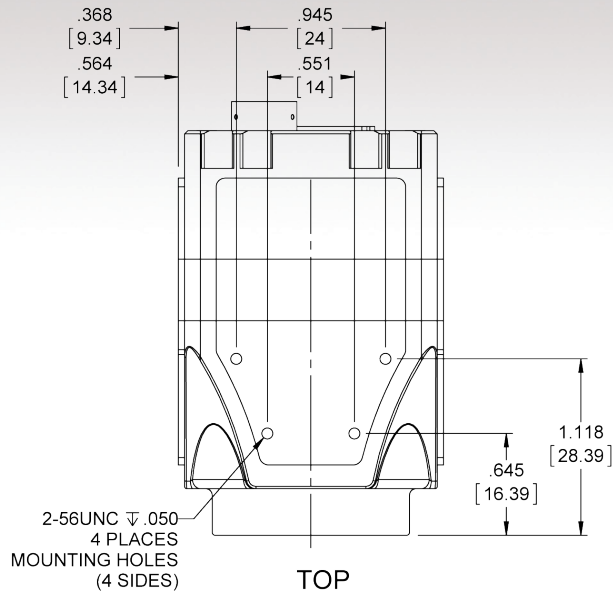

ALL DIMENSIONS DISPLAYED AS INCHES (MM)

