

VC series

User Manual

English

VC-12MX-M/C 330 F

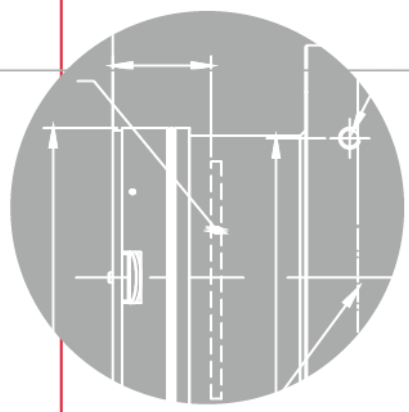

VIEWWORKS

Revision History

Version	Date	Description
1.0	2017-04-10	Initial Release
1.1	2018-10-31	Changed the model name (VC-12MX2-M/C 330 → VC-12MX-M/C 330 F)
1.2	2019-10-23	Changed the frame rates
1.3	2020-09-18	<ul style="list-style-type: none">• Applied new CI• Added the Reverse X feature
1.4	2022-04-20	<ul style="list-style-type: none">• Added the High Dynamic Range feature

Contents

1	Precautions	5
2	Warranty	6
3	Compliance & Certifications	6
3.1	FCC Compliance	6
3.2	CE: DoC	6
3.3	KC	6
4	Package Components	7
5	Product Specifications	8
5.1	Overview	8
5.2	Specifications	9
5.3	Camera Block Diagram	10
5.4	Sensor Information	11
5.5	Mechanical Specification	12
6	Installation	13
6.1	Precaution to Center the Image Sensor.....	14
6.2	Precaution about Blurring Compared to Center	14
6.3	Installing Vieworks Imaging Solution.....	14
7	Camera Interface	15
7.1	General Description.....	15
7.2	CoaXPress Connector	16
7.2.1	CoaXPress DIN Connector (75 Ω 1.0/2.3 DIN Receptacle).....	16
7.3	Power Input Receptacle.....	17
7.4	Control I/O Receptacle	18
7.5	Trigger Input Circuit	19
7.6	Strobe Output Circuit	20
8	Acquisition Control	21
8.1	Overview	21
8.2	Acquisition Start/Stop Commands and Acquisition Mode.....	24
8.3	Exposure Start Trigger.....	25
8.3.1	Trigger Mode	25
8.3.2	Using a CoaXPress Trigger Signal	27
8.3.3	Using an External Trigger Signal	28
8.4	Setting the Exposure Time.....	31
8.5	Overlapping Exposure with Sensor Readout	32
8.6	Real Exposure.....	34

8.6.1	Timed Exposure Mode.....	34
8.6.2	Trigger Width Exposure Mode	35
8.7	Electronic Shutter Operation.....	36
8.7.1	Global Shutter.....	36
8.8	Maximum Allowed Frame Rate	37
8.8.1	Increasing the Maximum Allowed Frame Rate.....	37
9	Camera Features.....	38
9.1	Image Region of Interest	38
9.2	CXP Link Configuration	41
9.3	Pixel Format	42
9.4	Data ROI (Color Camera).....	43
9.5	White Balance (Color Camera).....	44
9.5.1	Balance White Auto	44
9.6	Gain and Black Level.....	45
9.7	Defective Pixel Correction	46
9.7.1	Correction Method	46
9.8	Flat Field Correction	47
9.9	High Dynamic Range.....	50
9.10	Temperature Monitor	51
9.11	Status LED	51
9.12	Test Pattern	52
9.13	Reverse X	55
9.14	Digital IO Control	56
9.15	Fan Control.....	58
9.16	Device User ID	58
9.17	Device Reset.....	58
9.18	User Set Control.....	59
9.19	Field Upgrade.....	59
10	Troubleshooting.....	60
Appendix A	Defect Pixel Map Download.....	61
Appendix B	Field Upgrade.....	63
B.1	MCU	63
B.2	FPGA	65
B.3	XML.....	66

1 Precautions

General



- Do not drop, disassemble, repair or alter the device. Doing so may damage the camera electronics and cause an electric shock.
- Do not let children touch the device without supervision.
- Stop using the device and contact the nearest dealer or manufacturer for technical assistance if liquid such as water, drinks or chemicals gets into the device.
- Do not touch the device with wet hands. Doing so may cause an electric shock.
- Make sure that the temperature of the camera does not exceed the temperature range specified in [5.2 Specifications](#). Otherwise the device may be damaged by extreme temperatures.

Installation and Maintenance



- Do not install in dusty or dirty areas - or near an air conditioner or heater to reduce the risk of damage to the device.
- Avoid installing and operating in an extreme environment where vibration, heat, humidity, dust, strong magnetic fields, explosive/corrosive mists or gases are present.
- Do not apply excessive vibration and shock to the device. This may damage the device.
- Avoid direct exposure to a high intensity light source. This may damage the image sensor.
- Do not install the device under unstable lighting conditions. Severe lighting change will affect the quality of the image produced by the device.
- Do not use solvents or thinners to clean the surface of the device. This can damage the surface finish.

Power Supply



- Applying incorrect power can damage the camera. If the voltage applied to the camera is greater or less than the camera's nominal voltage, the camera may be damaged or operate erratically. Please refer to [5.2 Specifications](#) for the camera's nominal voltage.
 - ※ Vieworks Co., Ltd. does NOT provide power supplies with the devices.
- Make sure the power is turned off before connecting the power cord to the camera. Otherwise, damage to the camera may result.

2 Warranty

Do not open the housing of the camera. The warranty becomes void if the housing is opened.
For information about the warranty, please contact your local dealer or factory representative.

3 Compliance & Certifications

3.1 FCC Compliance

This equipment has been tested and found to comply with the limits for a Class A digital device, pursuant to part 15 of the FCC Rules. These limits are designed to provide reasonable protection against harmful interference when the equipment is operated in a commercial environment. This equipment generates, uses, and can radiate radio frequency energy and, if not installed and used in accordance with the instruction manual, may cause harmful interference to radio communications. Operation of this equipment in a residential area is likely to cause harmful interference in which case the user will be required to correct the interference at his own expenses.

3.2 CE: DoC

EMC Directive 2014/30/EU
EN 55032:2012 (Class A), EN 55024:2010
Class A

3.3 KC

KCC Statement

Type	Description
Class A (Broadcasting Communication Device for Office Use)	This device obtained EMC registration for office use (Class A), and may be used in places other than home. Sellers and/or users need to take note of this.

4 Package Components

Package Components

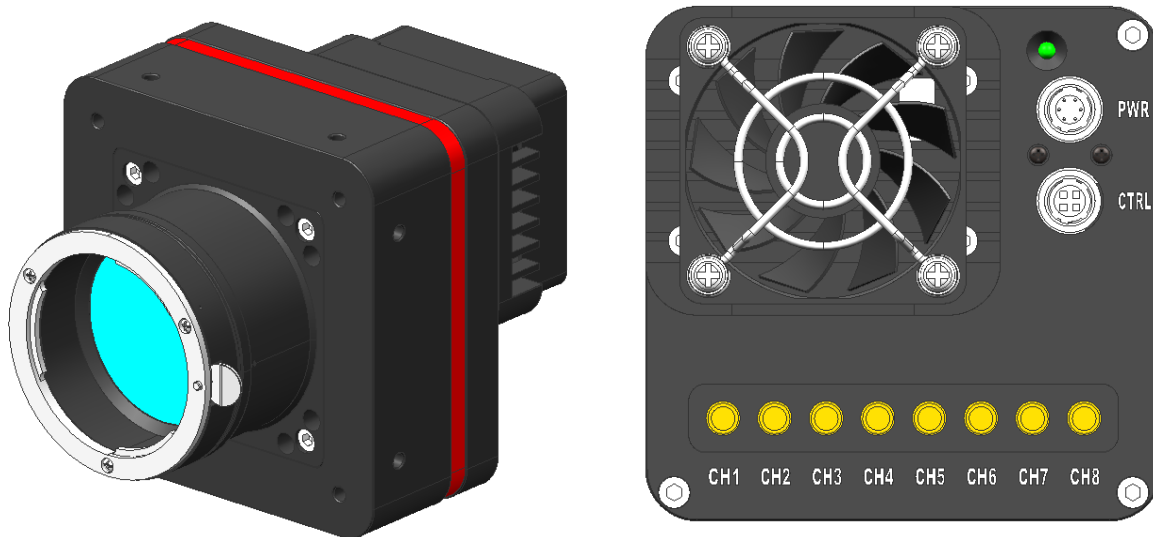

VC-12MX-330 F with a fan



M5 Set Screws for Tilt Adjustment (Provided only with F-mount camera)



- You can adjust the tilt using the M5 set screws, however it is not recommended since it is adjusted as factory default settings.
- If the tilt settings need to be adjusted inevitably, please contact your local dealer or factory representative for technical support.

5 Product Specifications

5.1 Overview

The VC-12MX-330 F camera is a new 12 megapixel camera addition to its industrial proven VC series. Equipped with the Viewworks' innovative technologies proved by world's top FPD manufacturers, this camera offers not only the fastest frame rate but also highly uniformed images. This camera support 12 megapixel resolutions with frame rate up to 335 fps (CoaXPress – 8 CH). Its CoaXPress interface supports transmitting image data at up to 25 Gbps using four coaxial cables and up to 50 Gbps using eight cables. Featured with high quality image uniformity and high resolution, this camera is ideal for demanding applications such as FPD, PCB, and semiconductor inspections.

Main Features

- High Speed 12 Megapixel CMOS Image Sensor
- Electronic Exposure Time Control (Global Shutter)
- 8 bit Output Pixel Format
- Strobe Output
- CoaXPress Interface up to 335 fps at 50 Gbps using 8 channels
- Gain/Black Level Control
- Test Pattern
- Temperature Monitor
- Field Upgrade
- Image Correction
- Flat Field Correction
- Defective Pixel Correction
- Fan Control
- VC-12MX-330 F Feature Bar



5.2 Specifications

Technical specifications for the VC-12MX-330 F camera are as follows:

VC CXP Series		VC-12MX-M/C 330 F
Active Image (H × V)		4096 × 3072
Sensor Type		CMOSIS CMV 12000
Pixel Size		5.5 μm × 5.5 μm
Sensor Size		22.5 mm × 16.9 mm (Diagonal: 28.16 mm)
Output	Mono	Mono 8
Format	Color	Bayer 8
Camera Interface		CoaXPress
Electronic Shutter		Global Shutter
Max. Frame Rate at Full Resolution		188 fps at 6.25 Gbps with 4 CH 335 fps at 6.25 Gbps with 8 CH
Dynamic Range		54 dB
Shutter Speed (1 μs step)		16 μs ~ 60 s
Partial Scan (Max. Speed)		27777 fps at 4 Lines
Black Level (1 LSB step)		0 ~ 16 LSB at 8 bit
Video Gain		1× ~ 4× (0~ 12 dB)
Exposure Mode		Free Run, Timed, Trigger Width
External Trigger		3.3 V ~ 24.0 V, 10 mA, Logical Level Input optically isolated, CoaXPress Control Port
Software Trigger		Asynchronous, Programmable via Camera API
API SDK		Viewworks Imaging Solution 7.X
Lens Mount		F-mount, Custom mount available upon request
Power	Adapter	8 ~ 30 V DC, Typ. 18 W
	PoCXP	24 V DC, Minimum of four PoCXP cables required
Environmental		Operating: 0°C ~ 40°C (Housing: 10°C ~ 50°C), Storage: -40°C ~ 70°C
Mechanical		90 mm × 90 mm × 114 mm, 745g (with F-mount)

Table 5.1 Specifications of VC-12MX-330 F

5.3 Camera Block Diagram

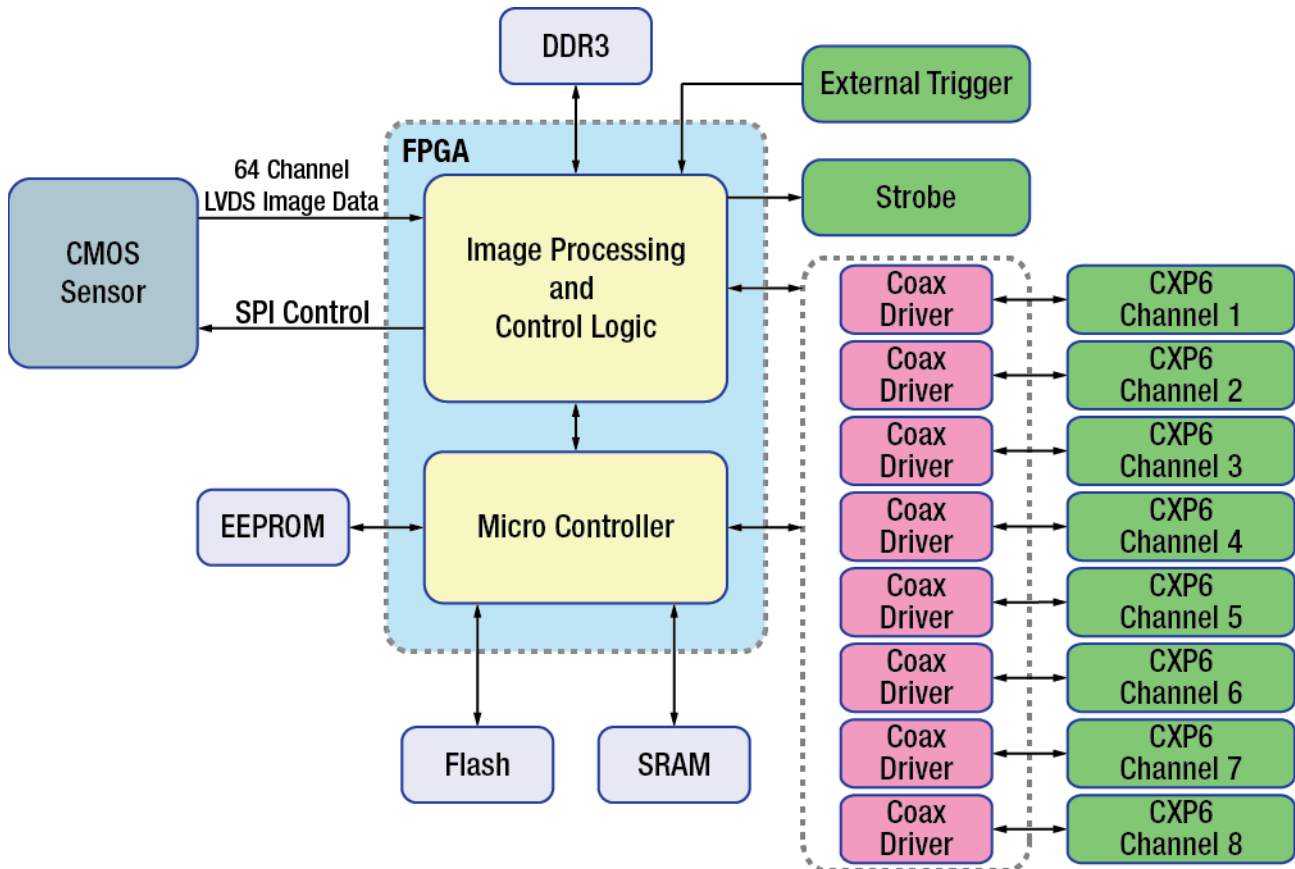

Figure 5.1 VC-12MX-330 F Block Diagram

All controls and data processing of the camera are carried out in one FPGA chip. The FPGA generally consists of a 32 bit RISC Micro-Controller and Processing & Control logic. The Micro-Controller receives commands from the user through the CoaXPress interface and then processes them. The Processing & Control Logic processes the image data received from the CMOS sensor and then transmits data through the CoaXPress interface. And also, the Processing & Control Logic controls the trigger input and strobe output signals which are sensitive to time. Furthermore, a DDR3 for the frame buffer to process images and a Flash for operating Micro-Controller are installed outside FPGA.

5.4 Sensor Information

The following graph shows the spectral response for the VC-12MX-330 F monochrome and color camera.

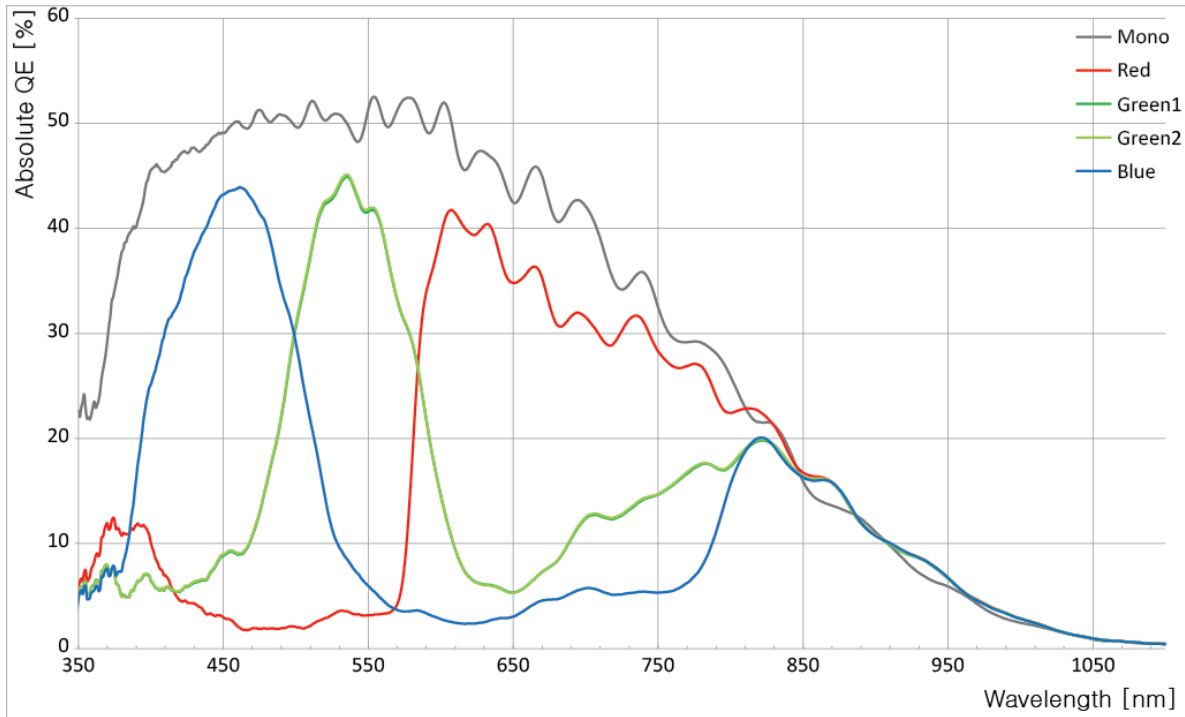

Figure 5.2 Mono and Color Spectral Response for VC-12MX-330 F

5.5 Mechanical Specification

The camera dimensions in millimeters are as shown in the following figure.

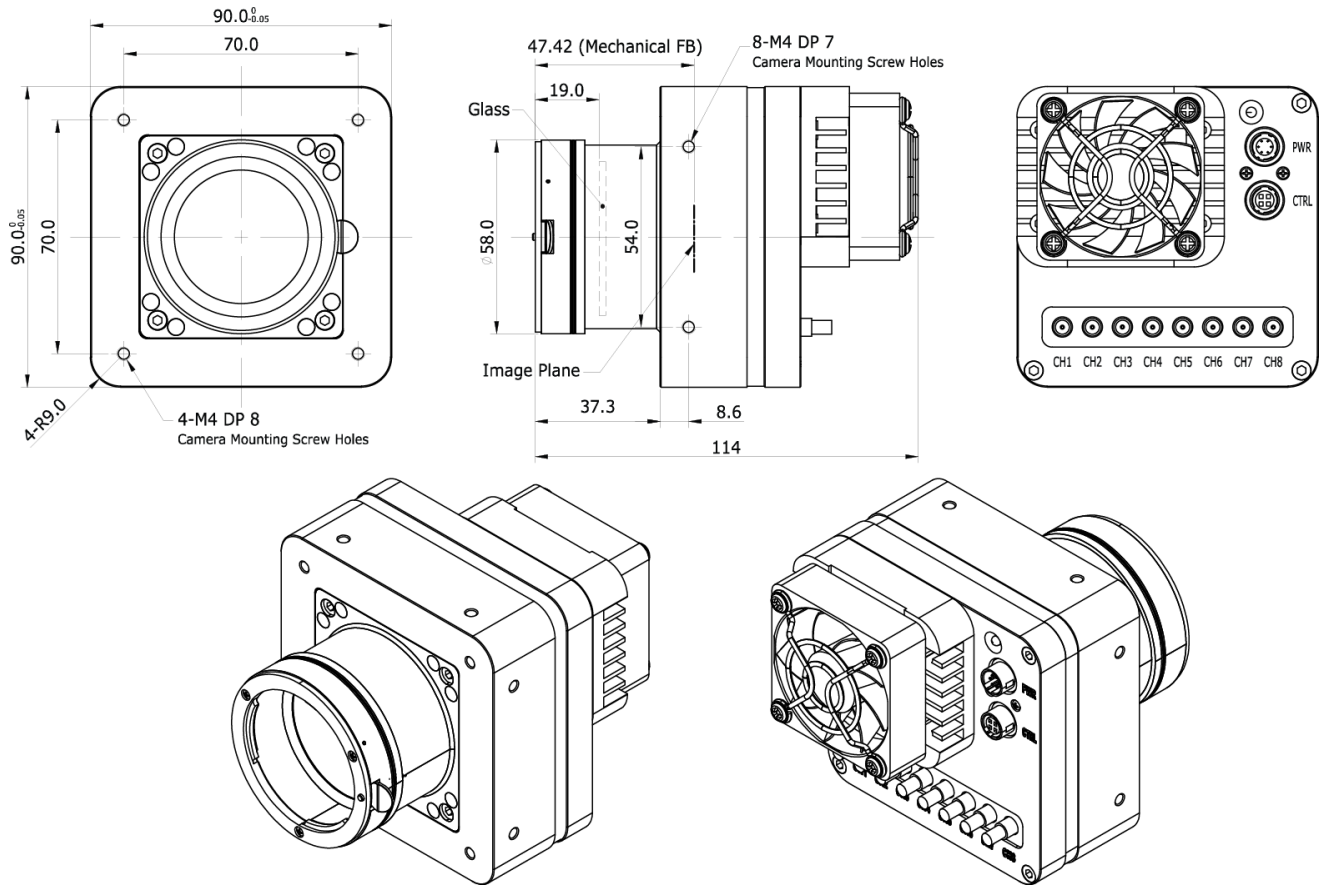

Figure 5.3 Mechanical Dimensions for VC-12MX-330 F F-mount with a fan

6 Installation

The following instructions assume that you have installed a 8 Channel CoaXPress Frame Grabber (hereinafter 'CXP Frame Grabber') in your computer including related software. Procedures below also assume that you may attempt to configure a link between a camera and CXP Frame Grabber by using eight coax cables. For more detailed information, refer to your CXP Frame Grabber User Manual. To connect the camera to your computer, follow the steps below:

1. Make sure that the power supply is not connected to the camera and your computer is turned off.
 - Go on to step 2 if you are using a power supply.
 - Go on to step 3 if you are using a Power over CoaXPress (PoCXP) Frame Grabber.
2. **If you are using a power supply:**
 - a. Plug one end of a coax cable into the CH1 of the CXP connector on the camera and the other end of the coax cable into the CH1 of the CXP Frame Grabber in your computer. Then, plug one ends of the other seven coax cables into CH2, CH3, CH4, CH5, CH6, CH7 and CH8 of the CXP connector on the camera and the other ends of the coax cables into the CH2, CH3, CH4, CH5, CH6, CH7 and CH8 of the CXP Frame Grabber respectively.
 - b. Connect the plug of the power adapter to the 6-pin power input receptacle on the camera.
 - c. Plug the power adapter into a working electrical outlet.
3. **If you are using PoCXP Frame Grabber:**
 - a. Plug one end of a coax cable into the CH1 of the CXP connector on the camera and the other end of the coax cable into the CH1 of the CXP Frame Grabber in your computer. Then, plug one ends of the other seven coax cables into CH2, CH3, CH4, CH5, CH6, CH7 and CH8 of the CXP connector on the camera and the other ends of the coax cables into the CH2, CH3, CH4, CH5, CH6, CH7 and CH8 of the CXP Frame Grabber respectively.
 - b. You must connect the CH1, CH2, CH3 and CH4 channels to power the camera via PoCXP.
4. Verify all the cable connections are secure.

Precautions for using Power over CoaXPress



To power a camera via PoCXP Frame Grabber, you must connect the CH1, CH2, CH3 and CH4 channels of the camera to their respective connectors on the CXP Frame Grabber.

6.1 Precaution to Center the Image Sensor

- Users do not need to center the image sensor as it is adjusted as factory default settings.
- When you need to adjust the center of the image sensor, please contact your local dealer or the manufacturer for technical assistance.

6.2 Precaution about Blurring Compared to Center

- Users do not need to adjust the tilt as it is adjusted as factory default settings.
- If the tilt settings need to be adjusted inevitably, please contact your local dealer or factory representative for technical support.

6.3 Installing Vieworks Imaging Solution

You can download the Vieworks Imaging Solution at <http://www.vieworks.com>. You should perform the software installation first and then the hardware installation.

7 Camera Interface

7.1 General Description

As shown in the figure below, 3 types of connectors and a status indicator LED are located on the back of VC-12MX-330 F and have the functions as follows:

- ① Status LED: displays power status and operation mode.
- ② 6 pin power input receptacle: supplies power to the camera (if PoCXP is not used).
- ③ 4 pin control receptacle: provides access to the camera's I/O lines.
- ④ CoaXPress connector: controls video data and the camera.

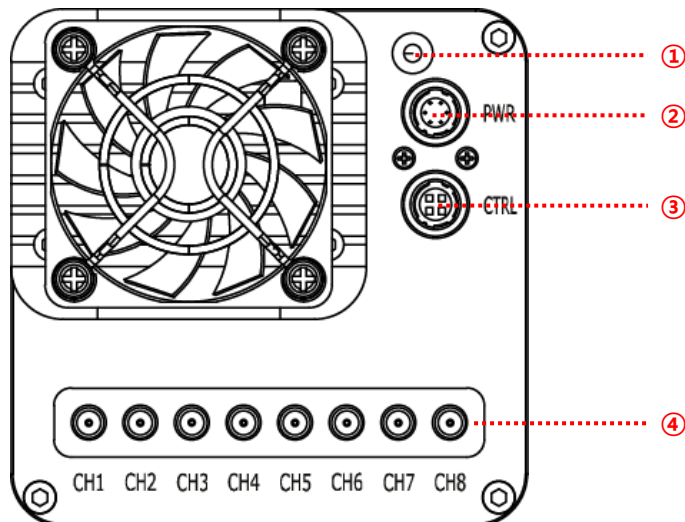

Figure 7.1 VC-12MX-330 F with DIN 1.0/2.3-type Connectors

7.2 CoaXPress Connector

CoaXPress protocol includes an automatic link detection mechanism (Plug and Play) to correctly detect the camera to the CXP Frame Grabber connection. The connection between the camera and CXP Frame Grabber uses a coax (also known as 'coaxial') cable and provides up to 6.25 Gbps bit rate per cable.

The VC-12MX-330 F camera can be powered over the cable if you are using a PoCXP enabled Frame Grabber.

7.2.1 CoaXPress DIN Connector (75 Ω 1.0/2.3 DIN Receptacle)

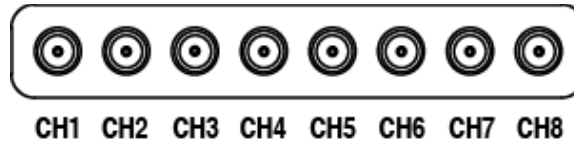

Figure 7.2 CoaXPress DIN 1.0/2.3-type Connectors

The CoaXPress connector on the VC-12MX-330 F camera complies with the CoaXPress standard and the following table shows the channel assignments.

Channel	Max. Bit Rate per Coax	Type	PoCXP Compliant
CH1	6.25 Gbps	Master Connection	Yes
CH2	6.25 Gbps	Extension Connection	Yes
CH3	6.25 Gbps	Extension Connection	Yes
CH4	6.25 Gbps	Extension Connection	Yes
CH5	6.25 Gbps	Extension Connection	No
CH6	6.25 Gbps	Extension Connection	No
CH7	6.25 Gbps	Extension Connection	No
CH8	6.25 Gbps	Extension Connection	No

Table 7.1 Channel Assignments for CoaXPress Connector



When you connect a camera to a CXP Frame Grabber using coax cables, make sure to connect the cables to their correct channels. If you connect the CH1 of the CXP connector on the camera to a channel other than CH1 of the CXP Frame Grabber, the camera may not transmit images properly or the communication between the computer and camera may fail.

7.3 Power Input Receptacle

The power input receptacle is a Hirose 6-pin connector (part # HR10A-7R-6PB). The pin assignments and configurations are as follows:

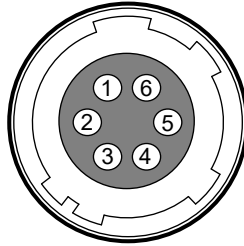

Figure 7.3 Pin Assignments for 6-pin Power Input Receptacle

Pin Number	Signal	Type	Description
1, 2, 3	+12V DC	Input	DC Power Input
4, 5, 6	DC Ground	Input	DC Ground

Table 7.2 Pin Arrangements for Power Input Receptacle



- A recommended mating connector for the Hirose 6-pin connector is the Hirose 6-pin plug (part # HR10A-7P-6S) or the equivalent.
- It is recommended that you use the power adapter, which has at least 3 A current output at 8 – 30 V voltage output (You need to purchase a power adapter separately.).

Precaution for Power Input



- Make sure the power is turned off before connecting the power cord to the camera. Otherwise, damage to the camera may result.
- If the voltage applied to the camera is greater than specified in the specifications, damage to the camera may result.

7.4 Control I/O Receptacle

The control I/O receptacle is a Hirose 4-pin connector (part # HR10A-7R-4S) and consists of an external trigger signal input and strobe output ports. The pin assignments and configurations are as follows:

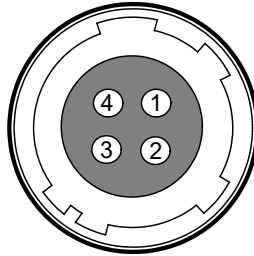

Figure 7.4 Pin Assignments for 4-pin Control I/O Receptacle

Pin Number	Signal	Type	Description
1	Trigger Input +	Input	-
2	Trigger Input -	Input	-
3	DC Ground	-	DC Ground
4	Strobe Out	Output	3.3 V TTL Output Output Resistance: 47 Ω

Table 7.3 Pin Arrangements for Control I/O Receptacle



A recommended mating connector for the Hirose 4-pin connector is the Hirose 4-pin plug (part # HR10A-7P-4P) or the equivalent.

7.5 Trigger Input Circuit

The following figures show the trigger signal input circuit of the 4-pin connector. Transmitted trigger signal is applied to the internal circuit through a photo coupler. The minimum trigger width that can be recognized by the camera is 1 μ s. If transmitted trigger signal is less than 1 μ s, the camera will ignore the trigger signal.

An external trigger circuit example is shown below.

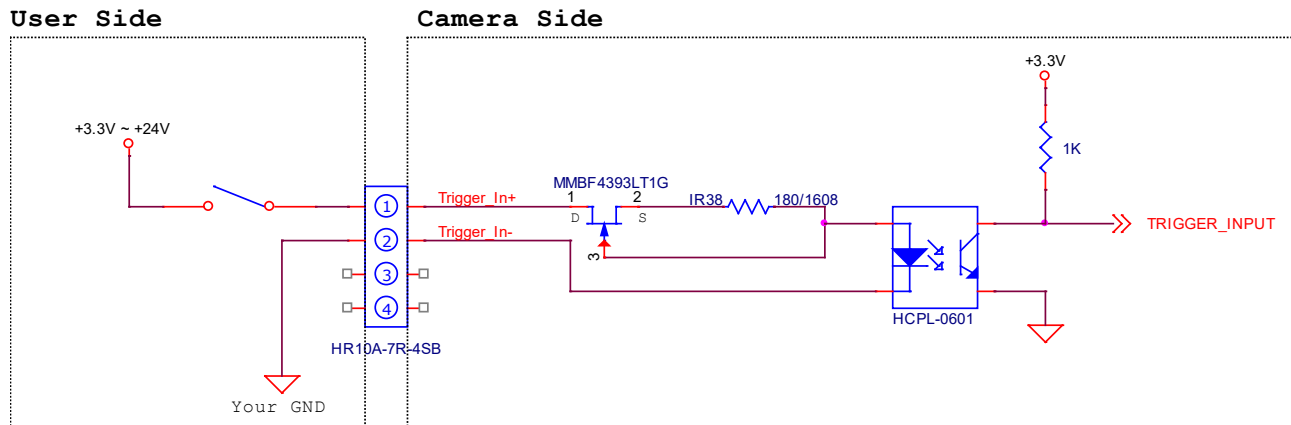

Figure 7.5 Trigger Input Schematic

7.6 Strobe Output Circuit

The strobe output signal comes out through a 3.3 V output level of TTL Driver IC. A pulse width of the signal is synchronized with an exposure (shutter) signal of the camera (refer to [9.12 Digital IO Control](#)).

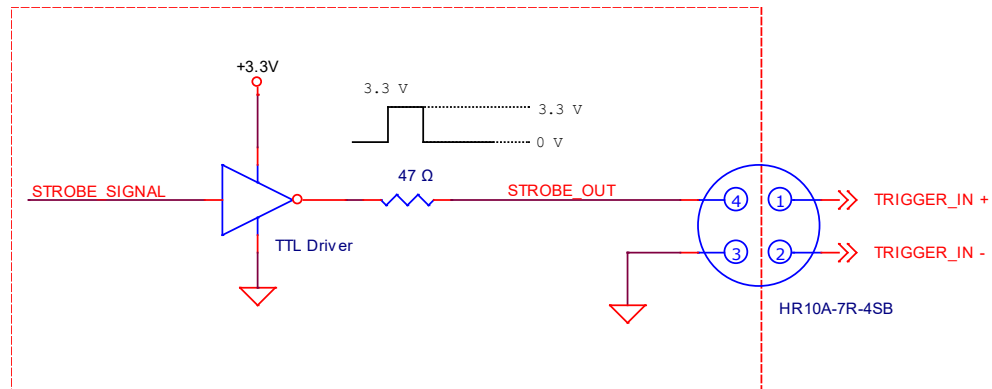

Figure 7.6 Strobe Output Schematic

8 Acquisition Control

This chapter provides detailed information about controlling image acquisition.

- Triggering image acquisition
- Setting the exposure time
- Controlling the camera's image acquisition rate
- Variation of the camera's maximum allowed image acquisition rate according to the camera settings

8.1 Overview

This section presents an overview of the elements involved with controlling the acquisition of images.

Three major elements are involved in controlling the acquisition of images:

- **Acquisition Start** and **Acquisition Stop** commands and the **Acquisition Mode** parameter
- Exposure Start trigger
- Exposure time control



When reading the explanations in the overview and in this entire chapter, keep in mind that the term **frame** is typically used to mean a single acquired image.

Acquisition Start and Stop Commands and the Acquisition Mode

The **Acquisition Start** command prepares the camera to acquire frames. The camera cannot acquire frames unless an **Acquisition Start** command has first been executed.

A parameter called the **Acquisition Mode** has a direct bearing on how the **Acquisition Start** command operates. The VC-12MX-330 F camera only support **Continuous** for the **Acquisition Mode** parameter.

If the **Acquisition Mode** parameter is set to **Continuous**, an **Acquisition Start** command does not expire after a single frame is acquired. Once an **Acquisition Start** command has been executed, you can acquire as many frames as you like. The **Acquisition Start** command will remain in effect until you execute an **Acquisition Stop** command. Once an **Acquisition Stop** command has been executed, the camera will not be able to acquire frames until a new **Acquisition Start** command is executed.

Exposure Start Trigger

Applying an exposure start trigger signal to the camera will exit the camera from the waiting for exposure start trigger acquisition status and will begin the process of exposing and reading out a frame (see Figure 8.1).

As soon as the camera is ready to accept another exposure start trigger signal, it will return to the waiting for exposure start trigger acquisition status. A new exposure start trigger signal can then be applied to the camera to begin another frame exposure.

The exposure start trigger has two modes: off and on.

If the **Trigger Mode** parameter is set to **Off**, the camera will generate all required exposure start trigger signals internally, and you do not need to apply exposure start trigger signals to the camera. The rate at which the camera will generate the signals and acquire frames will be determined by the way that you set several frame rate related parameters.

If the **Trigger Mode** parameter is set to **On**, you must trigger exposure start by applying exposure start trigger signals to the camera. Each time a trigger signal is applied, the camera will begin a frame exposure. When exposure start is being triggered in this manner, it is important that you do not attempt to trigger frames at a rate that is greater than the maximum allowed (There is a detailed explanation about the maximum allowed frame rate at the end of this chapter.). Exposure start trigger signals applied to the camera when it is not in a *waiting for exposure start trigger* acquisition status will be ignored.

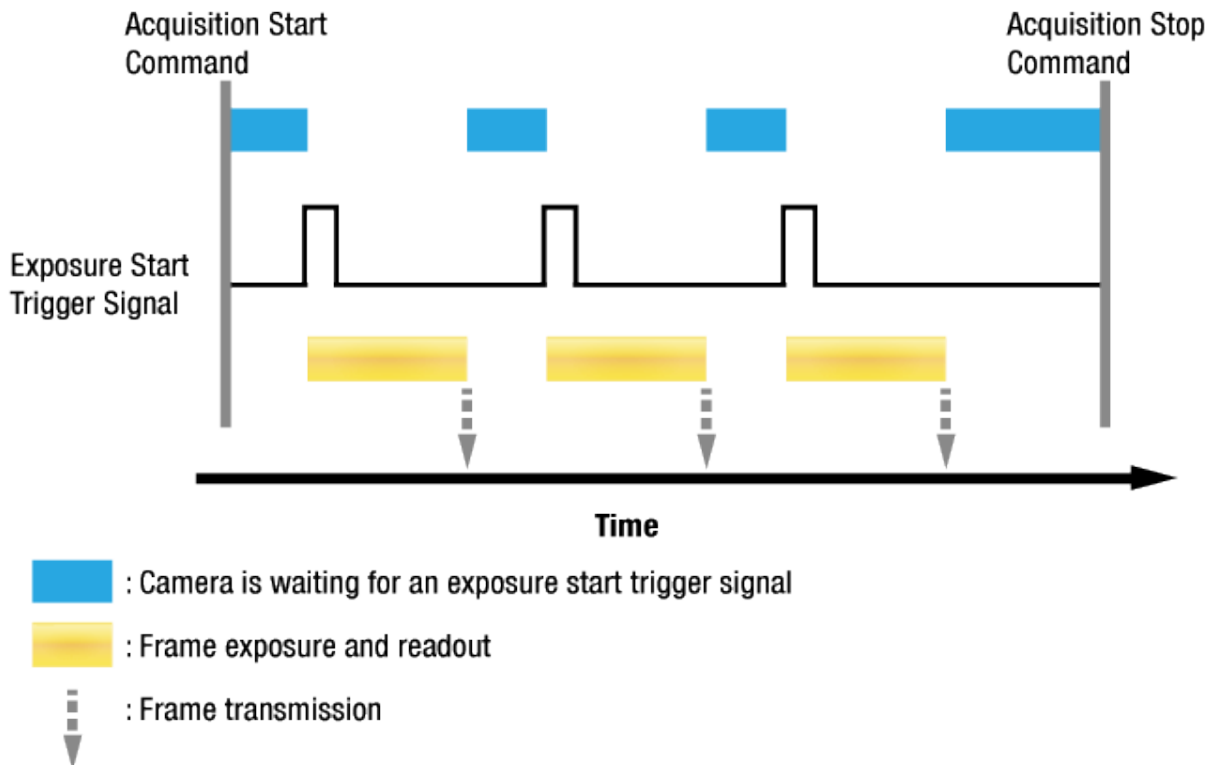

Figure 8.1 Exposure Start Triggering

Applying Trigger Signals

The paragraphs above mention "applying a trigger signal". There are two ways to apply an exposure start trigger signal to the camera: via **CXPin** or via **LineIn0** (commonly referred to as hardware).

To apply trigger signals via CH1 of the CXP Frame Grabber, you must set the **Trigger Source** parameter to **CXPin**. At that point, each time a proper CoaXPress trigger signal is applied to the camera by using the APIs provided by a CXP Frame Grabber manufacturer, the exposure start trigger signal will be applied to the camera. For more information, refer to your CXP Frame Grabber User Manual.

To apply trigger signals via hardware (external), you must set the **Trigger Source** parameter to **LineIn0**. At that point, each time a proper electrical signal is applied to the camera, an occurrence of the exposure start trigger signal will be recognized by the camera.

Exposure Time Control

When an exposure start trigger signal is applied to the camera, the camera will begin to acquire a frame.

A critical aspect of frame acquisition is how long the pixels in the camera's sensor will be exposed to light during the frame acquisition. The VC-12MX-330 F camera provides two exposure modes, **Timed** and **Trigger Width**.

With the **Timed** mode, the **Exposure Time** parameter will determine the exposure time for each frame.

With the **Trigger Width** mode, the way that you manipulate the rise and fall of the CoaXPress or external signal will determine the exposure time. The **Trigger Width** mode is especially useful if you want to change the exposure time from frame to frame.

8.2 Acquisition Start/Stop Commands and Acquisition Mode

Executing an **Acquisition Start** command prepares the camera to acquire frames. You must execute an **Acquisition Start** command before you can begin acquiring frames. Executing an **Acquisition Stop** command terminates the camera's ability to acquire frames. When the camera receives an **Acquisition Stop** command:

- If the camera is not in the process of acquiring a frame, its ability to acquire frames will be terminated immediately.
- If the camera is in the process of acquiring a frame, the frame acquisition process will be allowed to finish and the camera's ability to acquire new frames will be terminated.

The VC-12MX-330 F camera only provides the '**Continuous**' mode of operation for the **Acquisition Mode**. After an **Acquisition Start** command has been executed, exposure start can be triggered as desired. Each time an exposure start trigger is applied while the camera is in a waiting for *exposure start trigger* acquisition status, the camera will acquire and transmit a frame. The camera will retain the ability to acquire frames until an **Acquisition Stop** command is executed. Once the **Acquisition Stop** command is received, the camera will no longer be able to acquire frames.

8.3 Exposure Start Trigger

The **Trigger Selector** parameter is used to select a type of trigger and only the **Exposure Start** trigger is available on the VC-12MX-330 F camera. The Exposure Start trigger is used to begin frame acquisition. Exposure start trigger signals can be generated within the camera or may be applied externally by setting the **Trigger Source** parameter to **CXPin** or **LineIn0**. If an exposure start trigger signal is applied to the camera, the camera will begin to expose a frame.

8.3.1 Trigger Mode

The main parameter associated with the exposure start trigger is the **Trigger Mode** parameter. The **Trigger Mode** parameter for the exposure start trigger has two available settings: **Off** and **On**.

8.3.1.1 Trigger Mode = Off

When the **Trigger Mode** parameter is set to **Off**, the camera will generate all required exposure start trigger signals internally, and you do not need to apply exposure start trigger signals to the camera.

If the **Trigger Mode** parameter is set to **Off**, the camera will automatically begin generating exposure start trigger signals when it receives an **Acquisition Start** command. The camera will continue to generate exposure start trigger signals until it receives an **Acquisition Stop** command.



Free Run

When you set the **Trigger Mode** parameter to **Off**, the camera will generate all required trigger signals internally. When the camera is set this way, it will constantly acquire images without any need for triggering by the user. This use case is commonly referred to as “free run”.

The rate at which the exposure start trigger signals are generated may be determined by the camera's **Acquisition Frame Rate** parameter:

- If the parameter is set to a value less than the maximum allowed frame rate with the current camera settings, the camera will generate exposure start trigger signals at the rate specified by the parameter setting.
- If the parameter is set to a value greater than the maximum allowed frame rate with the current camera settings, the camera will generate exposure start trigger signals at the maximum allowed frame rate.

Exposure Time Control with Trigger Mode = Off

When the **Trigger Mode** parameter is set to **Off**, the exposure time for each frame acquisition is determined by the value of the camera's **Exposure Time** parameter. For more information about the **Exposure Time** parameter, see [8.4 Setting the Exposure Time](#).

8.3.1.2 Trigger Mode = On

When the **Trigger Mode** parameter is set to **On**, you must apply an exposure start trigger signal to the camera each time you want to begin a frame acquisition. The **Trigger Source** parameter specifies the source signal that will act as the exposure start trigger signal.

The available settings for the **Trigger Source** parameter are:

- **CXPIn:** You can apply an exposure start trigger signal via CH1 of the CXP Frame Grabber. For more information, refer to your CXP Frame Grabber User Manual.
- **LineIn0:** You can apply an exposure start trigger signal to the camera by injecting an externally generated electrical signal (commonly referred to as a hardware or external trigger signal) into the Control I/O receptacle on the camera. Refer to [7.5 Trigger Input Circuit](#) for more information.

If the **Trigger Source** parameter is set to **CXPIn** or **LineIn0**, you must also set the **Trigger Activation** parameter. The available settings for the **Trigger Activation** parameter are:

- **Rising Edge:** Specifies that a rising edge of the electrical signal will act as the exposure start trigger.
- **Falling Edge:** Specifies that a falling edge of the electrical signal will act as the exposure start trigger.

Exposure Time Control with Trigger Mode = On

When the **Trigger Mode** parameter is set to **On**, the exposure time for each frame acquisition can be controlled with the **Exposure Time** parameter or it can be controlled by manipulating the external trigger signal.

8.3.2 Using a CoaXPress Trigger Signal

If the **Trigger Mode** parameter is set to **On** and the **Trigger Source** parameter is set to **CXPIn**, you must apply a CoaXPress trigger signal to the camera to begin each frame acquisition. A CoaXPress trigger signal will act as the exposure start trigger signal for the camera. For more information, refer to your CXP Frame Grabber User Manual.

A rising edge or a falling edge of the CoaXPress signal can be used to trigger frame acquisition. The **Trigger Activation** parameter is used to select rising edge or falling edge triggering.

Assuming that the camera is in a waiting for *exposure start trigger* acquisition status, frame acquisition will start whenever the appropriate edge transition is received by the camera.

When the camera receives a CoaXPress trigger signal and begins exposure, it will exit the waiting for *exposure start trigger* acquisition status because at that point, it cannot react to a new exposure start trigger signal.

As soon as the camera is capable of reacting to a new exposure start trigger signal, it will automatically return to the waiting for *exposure start trigger* acquisition status.

When the camera is operating under control of a CoaXPress signal, the period of the CoaXPress trigger signal will determine the rate at which the camera is acquiring frames:

$$\frac{1}{\text{CoaXPress signal period in seconds}} = \text{Frame Rate}$$

For example, if you are operating a camera with a CoaXPress trigger signal period of 50 ms (0.05 s):

So in this case, the frame rate is 20 fps.

8.3.3 Using an External Trigger Signal

If the **Trigger Mode** parameter is set to **On** and the **Trigger Source** parameter is set to **LineIn0**, an externally generated electrical signal injected into the Control I/O Receptacle pin 1 will act as the exposure start trigger signal for the camera. This type of trigger signal is generally referred to as a hardware trigger signal.

A rising edge or a falling edge of the external signal can be used to trigger frame acquisition. The **Trigger Activation** parameter is used to select rising edge or falling edge triggering.

Assuming that the camera is in a waiting for *exposure start trigger* acquisition status, frame acquisition will start whenever the appropriate edge transition is received by the camera.

When the camera receives an external trigger signal and begins exposure, it will exit the waiting for *exposure start trigger* acquisition status because at that point, it cannot react to a new exposure start trigger signal.

As soon as the camera is capable of reacting to a new exposure start trigger signal, it will automatically return to the waiting for *exposure start trigger* acquisition status.

When the camera is operating under control of an external signal, the period of the external trigger signal will determine the rate at which the camera is acquiring frames:

$$\frac{1}{\text{External signal period in seconds}} = \text{Frame Rate}$$

For example, if you are operating a camera with an External trigger signal period of 50 ms (0.05 s):

So in this case, the frame rate is 20 fps.

8.3.3.1 Exposure Modes

If you are triggering the start of frame acquisition with an externally (CoaXPress or External) generated trigger signal, two exposure modes are available: **Timed** and **Trigger Width**.

Timed Exposure Mode

When the **Timed** mode is selected, the exposure time for each frame acquisition is determined by the value of the camera's **Exposure Time** parameter. If the camera is set for rising edge triggering, the exposure time starts when the external trigger signal rises. If the camera is set for falling edge triggering, the exposure time starts when the external trigger signal falls. Figure 8.2 illustrates timed exposure with the camera set for rising edge triggering.

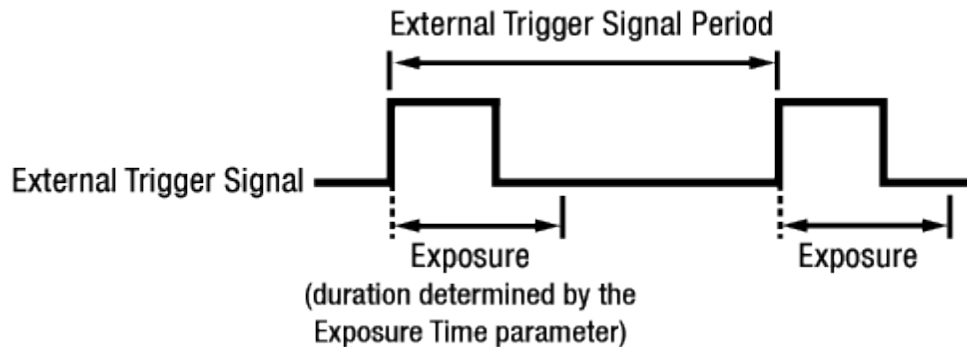

Figure 8.2 Timed Exposure Mode

Note that if you attempt to trigger a new exposure start while the previous exposure is still in progress, the trigger signal will be ignored.

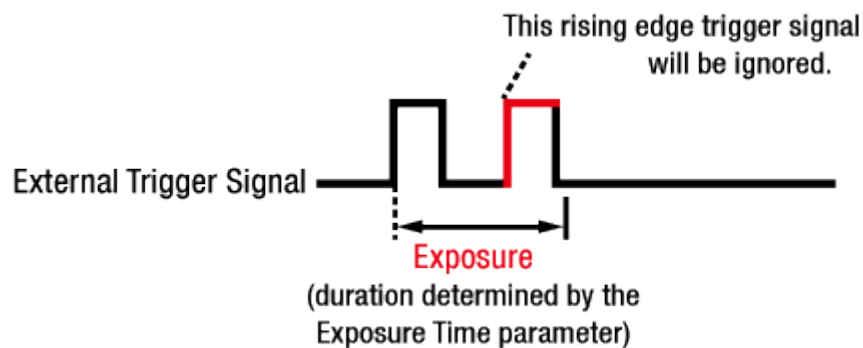

Figure 8.3 Trigger Overlapped with Timed Exposure Mode

Trigger Width Exposure Mode

When the **Trigger Width** exposure mode is selected, the length of the exposure for each frame acquisition will be directly controlled by the external trigger signal (CoaXPress or External). If the camera is set for rising edge triggering, the exposure time begins when the external trigger signal rises and continues until the external trigger signal falls. If the camera is set for falling edge triggering, the exposure time begins when the external trigger signal falls and continues until the external trigger signal rises. Figure 8.4 illustrates **Trigger Width** exposure with the camera set for rising edge triggering.

Trigger Width exposure is especially useful if you intend to vary the length of the exposure time for each frame.

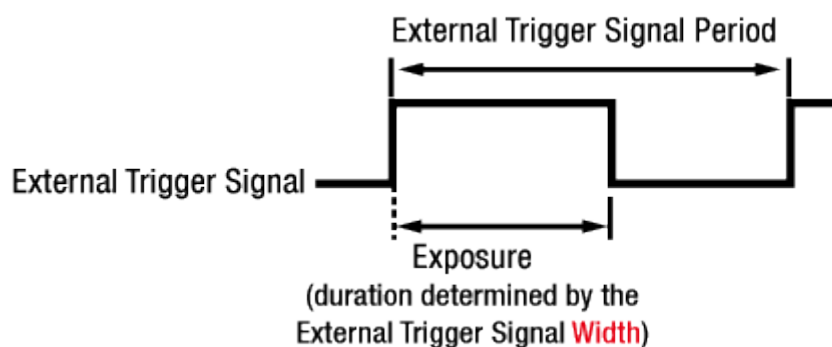

Figure 8.4 Trigger Width Exposure Mode

8.4 Setting the Exposure Time

This section describes how the exposure time can be adjusted manually by setting the value of the **Exposure Time** parameter. If you are operating the camera in any one of the following ways, you must specify an exposure time by setting the camera's **Exposure Time** parameter.

- the **Trigger Mode** is set to **Off**
- the **Trigger Mode** is set to **On** and the **Exposure Mode** is set to **Timed**.

The **Exposure Time** parameter must not be set below a minimum specified value. The **Exposure Time** parameter sets the exposure time in microseconds (μs). The minimum and maximum exposure time settings for each camera model are shown in the following table.

Camera Model	Number of Channels	Minimum Exposure Time	Maximum Exposure Time [†]
VC-12MX-330 F	4 Channels	16 μs	60,000,000 μs
	8 Channels	16 μs	60,000,000 μs

†: When the **Exposure Mode** is set to **Trigger Width**, the exposure time is controlled by the external trigger signal and has no maximum limit.

Table 8.1 Minimum and Maximum Exposure Time Setting

8.5 Overlapping Exposure with Sensor Readout

The frame acquisition process on the camera includes two distinct parts. The first part is the exposure of the pixels in the imaging sensor. Once exposure is complete, the second part of the process – readout of the pixel values from the sensor – takes place. In regard to this frame acquisition process, the VC-12MX-330 F camera basically operates with ‘overlapped’ exposure so that the exposure for a new frame can be overlapped with the sensor readout for the previous frame.

When the **Trigger Mode** parameter is set to **On**, the exposure of a new frame begins while the camera is still reading out the sensor data for the previously acquired frame. This situation is illustrated in Figure 8.5 with the **Trigger Source** parameter set to **LineIn0** and the **Exposure Mode** parameter set to **Trigger Width**.

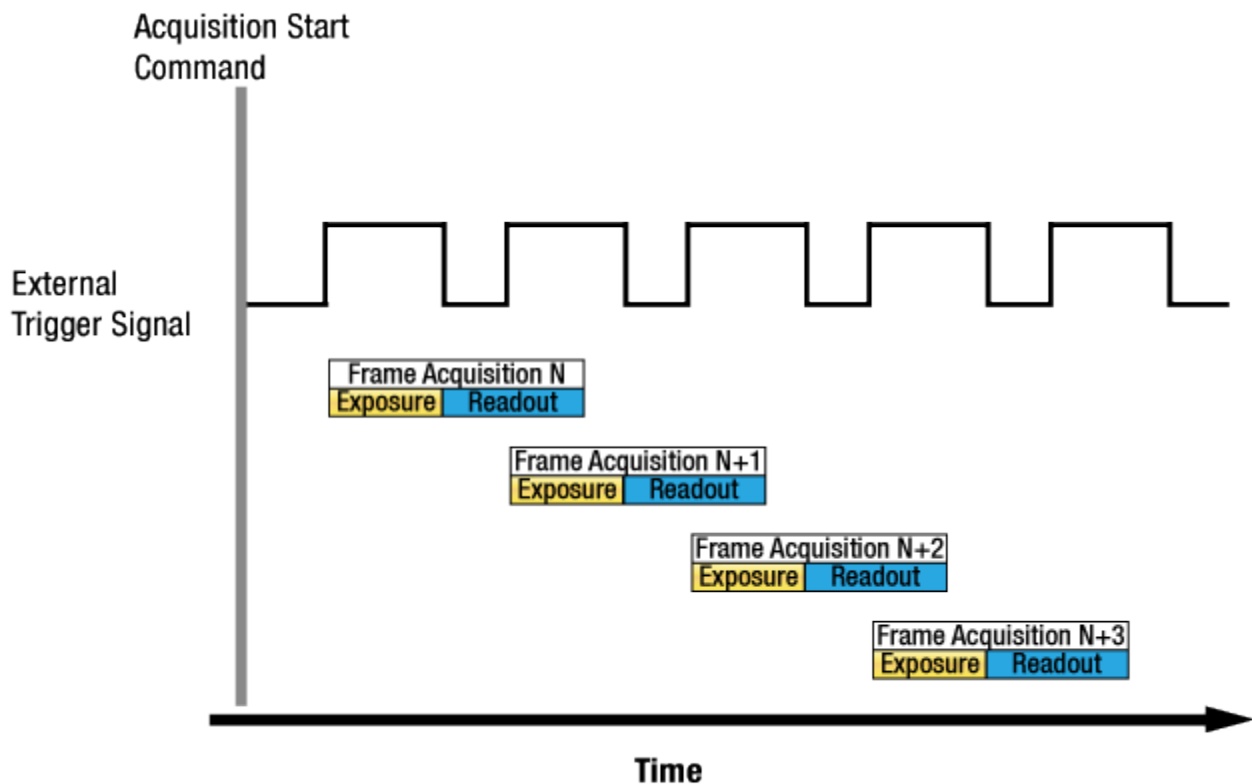

Figure 8.5 Overlapped Exposure and Readout

Determining whether your camera is operating with overlapped exposure and readout is not a matter of issuing a command or changing a setting. Rather a way that you operate the camera will determine whether the exposures and readouts are overlapped or not. If we define the “Frame Period” as the time from the start of exposure for one frame acquisition to the start of exposure for the next frame acquisition, then:

- Overlapped: $\text{Frame Period} \leq \text{Exposure Time} + \text{Readout Time}$

Guidelines for Overlapped Exposure

Since the VC-12MX-330 F camera operates with overlapped exposure, there are two important guidelines to keep in mind:

- You must not begin the exposure time for a new image acquisition while the exposure time of the previous acquisition is in progress.
- You must not end the exposure time of the current image acquisition until readout of the previously acquired image is complete.

When you are operating a camera with overlapped exposure and using an external trigger signal to trigger image acquisition, you could use the camera's Exposure Time parameter settings and timing formulas to calculate when it is safe to begin each new acquisition.

8.6 Real Exposure

8.6.1 Timed Exposure Mode

When you set the **Trigger Mode** parameter to **Off** or set the **Exposure Mode** parameter to **Timed**, the exposure time for each frame acquisition is determined by the value of the camera's **Exposure Time** parameter.

As soon as the camera detects an exposure start trigger signal, the camera will begin a frame exposure. When the exposure time ends, the pixels are being sampled and prepared for readout. This sequence is called the frame overhead time (FOT). Immediately after the FOT, the frame is read out automatically. During the FOT, an additional exposure time will be applied as an offset value shown in the figure below. This offset value varies depending on the camera's **CXP Link Configuration** parameter setting value. With the Timed exposure mode, the actual exposure time is equal to the camera's **Exposure Time** parameter setting value. This is true because the offset value is compensated on the actual exposure time automatically. The offset values and minimum allowed exposure time depending on the **CXP Link Configuration** setting are shown in the table below.

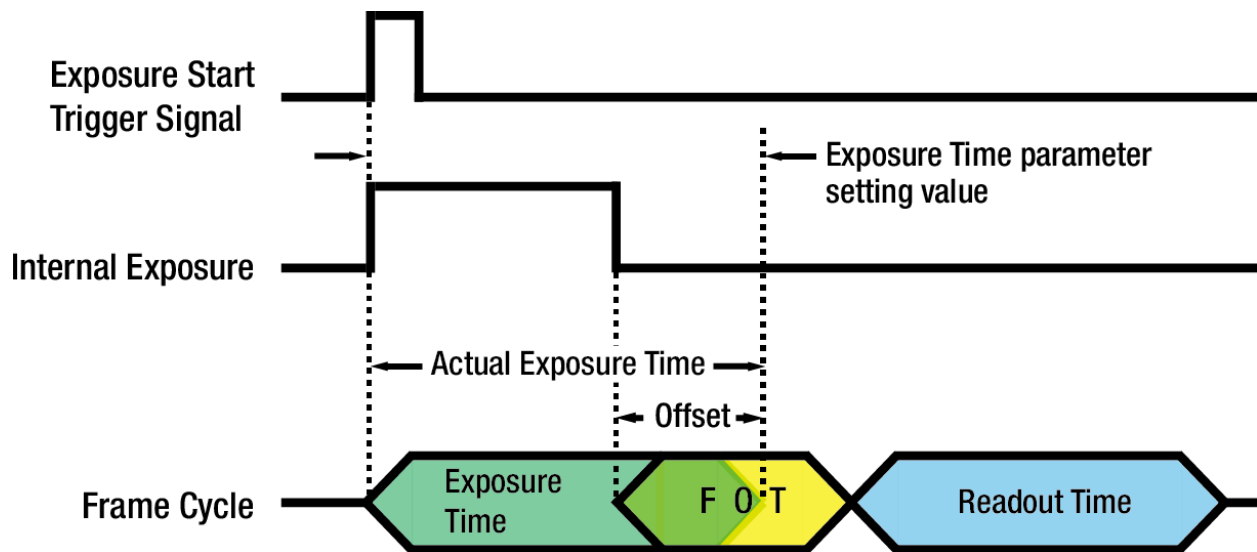

Figure 8.6 Real Exposure with Timed Exposure Mode

Camera Model	CXP Link Configuration	Offset Value	Minimum Exposure Time
VC-12MX-330 F	CXP6_X4	16 μ s	17 μ s
	CXP6_X8	16 μ s	17 μ s

Table 8.2 Offset Value and Minimum Exposure Time

8.6.2 Trigger Width Exposure Mode

When you set the **Exposure Mode** to **Trigger Width**, the exposure time is determined by the way that you manipulate the rise and fall (trigger width) of the external trigger signal. As soon as the camera detects an external trigger signal, the camera will begin a frame exposure and an additional exposure time will be applied as the offset value ([Table 8.2](#)) shown in the figure below.

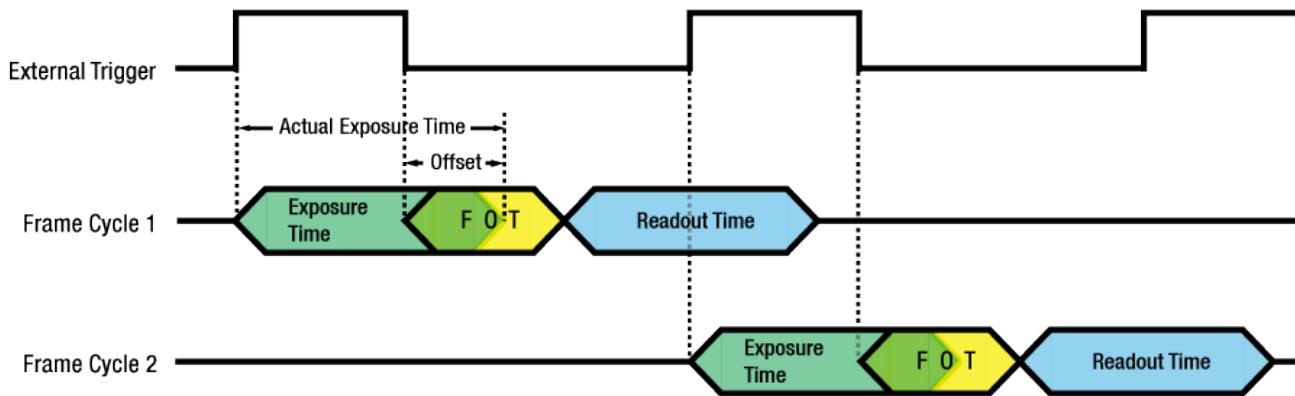

Figure 8.7 Real Exposure with Trigger Width Exposure Mode

8.7 Electronic Shutter Operation

The VC-12MX-330 F camera is equipped with an image sensor that has an electronic shutter. There are two types of electronic sensors (global and rolling). The VC-12MX-330 F camera uses sensors with global shutters.

8.7.1 Global Shutter

When an exposure start trigger signal is applied to the cameras equipped with a global shutter, exposure begins for all lines in the sensor as shown in Figure 8.8. Exposure continues for all lines in the sensor until the programmed exposure time ends or when the exposure start trigger signal ends the exposure time if the camera is using the trigger width exposure mode. At the end of the exposure time, exposure ends for all lines in the sensor. Immediately after the end of exposure, pixel data readout begins and proceeds line by line until all pixel data is read out of the sensor. A main characteristic of a global shutter is that for each frame acquisition, all of the pixels in the sensor start exposing at the same time and all end exposing at the same time. This means that image brightness tends to be more uniform over the entire area of each acquired image, and it helps to minimize problems with acquiring images of object in motion.

The cameras can provide a **Strobe Out** output signal that will go high when the exposure time for a frame acquisition begins and will go low when the exposure time ends.

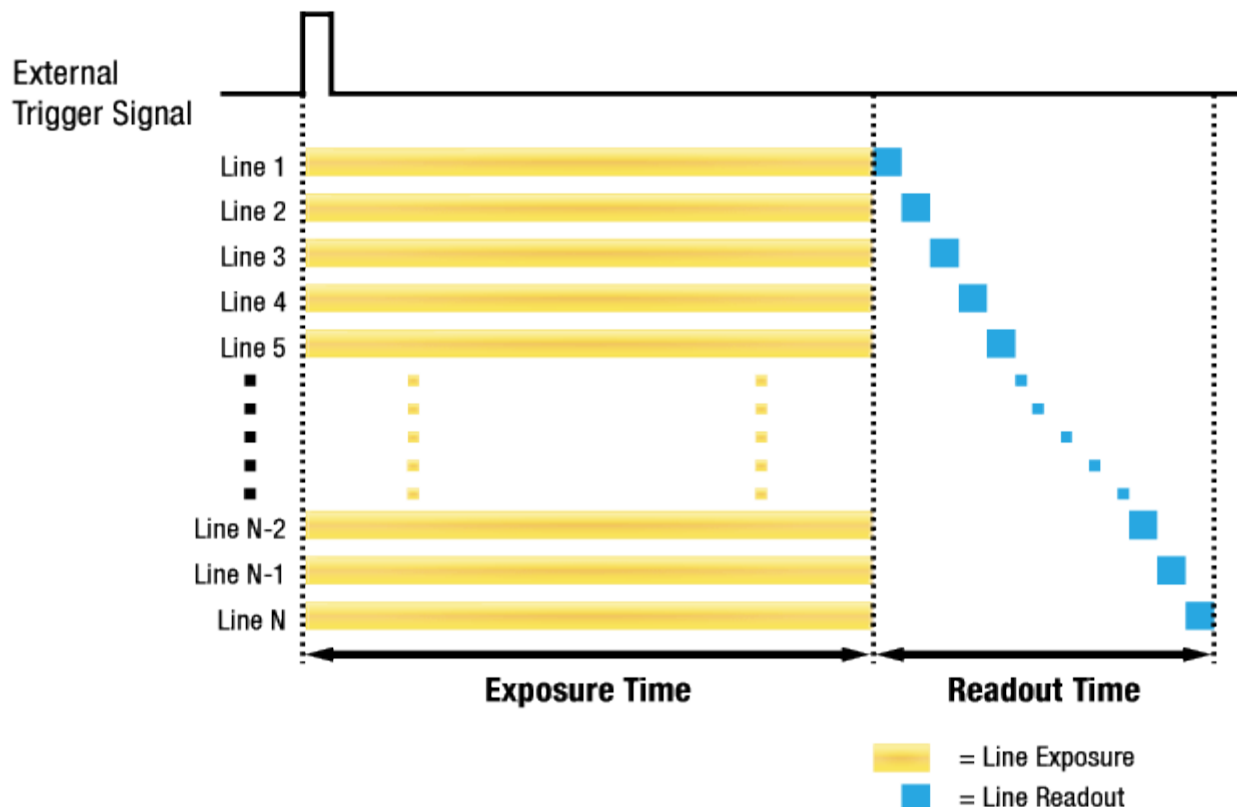

Figure 8.8 Global Shutter

8.8 Maximum Allowed Frame Rate

In general, the maximum allowed acquisition frame rate on the camera may be limited by several factors:

- The amount of time that it takes to transmit an acquired frame from the camera to your computer.
The amount of time needed to transmit a frame depends on the bandwidth assigned to the camera.
- The amount of time it takes to read an acquired frame out of the imaging sensor and into the camera's frame buffer. This time varies depending on the setting for the **Height** parameter. Frames with a smaller height take less time to read out of the sensor. The frame height is determined by the camera's **Height** settings (**Image Format Control**).
- The exposure time for acquired frames. If you use very long exposure times, you can acquire fewer frames per second.

8.8.1 Increasing the Maximum Allowed Frame Rate

You may find that you would like to acquire frames at a rate higher than the maximum allowed with the camera's current settings. In this case, you must adjust one or more of the factors that can influence the maximum allowed frame rate and then check to see if the maximum allowed frame rate has increased:

- The time that it takes to transmit a frame out of the camera is the main limiting factor on the frame rate. You can decrease the frame transmission time (and thus increase the maximum allowed frame rate) by using the ROI feature.
 - Use a smaller ROI. Decreasing the ROI means that the camera has less data to transmit and therefore the transmission time will decrease.
- If you are using normal exposure times and you are using the camera at its maximum resolution, your exposure time will not normally restrict the frame rate. However, if you are using long exposure times or small region of interest, it is possible that your exposure time is limiting the maximum allowed frame rate. If you are using a long exposure time or a small ROI, try using a shorter exposure time and see if the maximum allowed frame rate increases. You may need to compensate for a lower exposure time by using a brighter light source or increasing the opening of your lens aperture.



A very long exposure time severely limits the camera's maximum allowed frame rate.

As an example, assume that your camera is set to use a 1 second exposure time. In this case, because each frame acquisition will take at least 1 second to be completed, the camera will only be able to acquire a maximum of one frame per second.

9 Camera Features

9.1 Image Region of Interest

The Image Region of Interest (ROI) feature allows you to specify a portion of the sensor array. You can acquire only the frame data from the specified portion of the sensor array while preserving the same quality as you acquire a frame from the entire sensor array. With the ROI feature, you can achieve increased frame rates by decreasing the height of the ROI; however, decreasing the width of the ROI does not affect the frame rate. The ROI is referenced to the top left corner [origin (0, 0)] of the sensor array as follows.

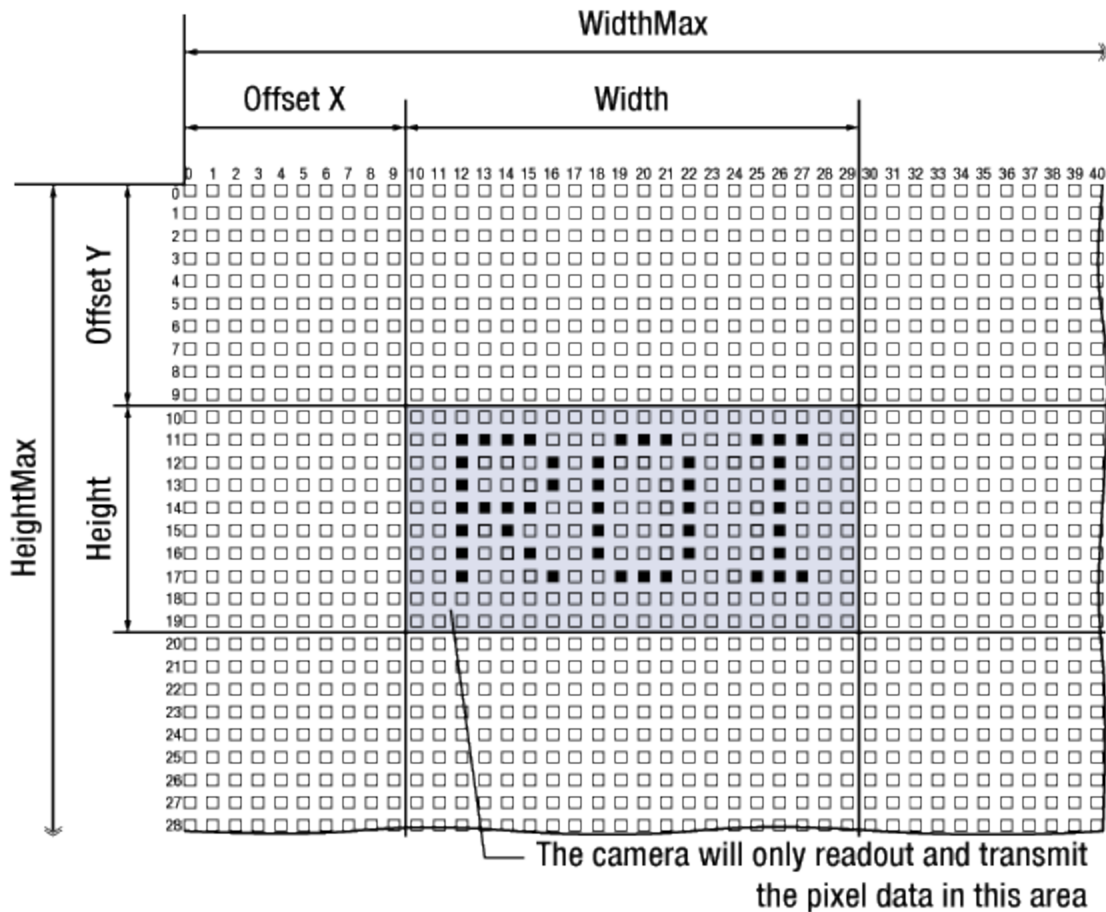

Figure 9.1 Image Region of Interest

The XML parameters related to ROI settings are as follows.

XML Parameters		Value	Description
ImageFormatControl	SensorWidth ^a	-	Effective width of the sensor
	SensorHeight ^a	-	Effective height of the sensor
	WidthMax	-	Maximum allowed width of the image with the current camera settings
	HeightMax	-	Maximum allowed height of the image with the current camera settings
	Width ^b	-	Current width of the image
	Height ^b	-	Current height of the image
	OffsetX ^c	-	Horizontal offset from the origin to the Image ROI
	OffsetY ^c	-	Vertical offset from the origin to the Image ROI

The unit for all parameters in this table is pixel

a: Read only. User cannot change the value

b: User configurable parameters for setting ROI

c: User configurable parameters for setting the origin of the ROI

Table 9.1 XML parameters related to ROI

You can change the size of ROI by setting the **Width** and **Height** parameters. And also, you can change the position of the ROI origin by setting the **Offset X** and **Offset Y** parameters.

Make sure that the **Width** + **Offset X** value is less than the **Width Max** value, and the **Height** + **Offset Y** value is less than the **Height Max** value. You must set the size of the ROI first, and then set the Offset values since the **Width** and **Height** parameters are set to its maximum value by default.

- On the **VC-12MX-330 F** camera, the **Width** parameter must be set to a multiple of 32, and the **Height** parameter must be set to a multiple of 4.

The minimum allowed setting values for the ROI Width and Height are shown below.

Camera Model	Minimum Width Settings	Minimum Height Settings
VC-12MX-330 F	256	4

Table 9.2 Minimum ROI Width and Height Settings

On the VC-12MX-330 F camera, the maximum frame rates depending on Vertical ROI changes are shown below.

ROI Size (H × V)	4 Channels	8 Channels
4096 × 4	23255 fps	27777 fps
4096 × 500	1116 fps	1953 fps
4096 × 1000	569 fps	1008 fps
4096 × 1500	382 fps	679 fps
4096 × 2000	287 fps	512 fps
4096 × 2500	230 fps	411 fps
4096 × 3072	188 fps	335 fps

Table 9.3 Maximum Frame Rates by VC-12MX-330 F ROI Changes

9.2 CXP Link Configuration

The VC-12MX-330 F camera must be connected to a CXP Frame Grabber installed in your computer via CoaXPress interface. CoaXPress interface allows you to connect a camera to a CXP Frame Grabber by using simple coax cabling and allows up to 6.25 Gbps data rate per cable. The VC-12MX-330 F camera supports one master connection and up to seven extension connections to configure a link. In compliance with the CoaXPress standard, the VC-12MX-330 F camera includes an automatic link detection mechanism to correctly detect the camera to CXP Frame Grabber connections.

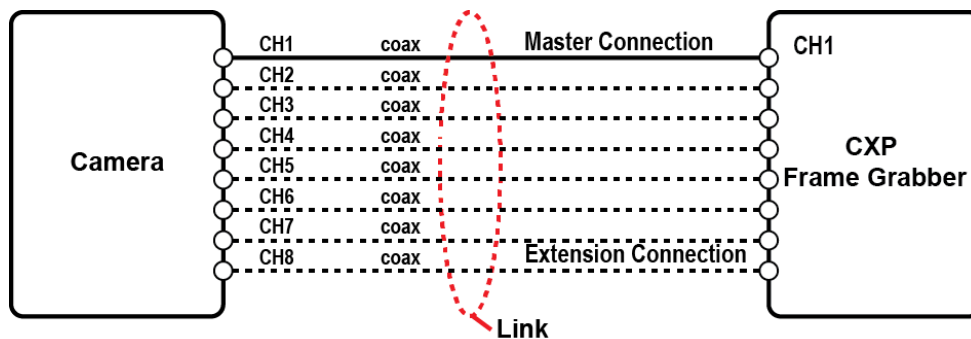

Figure 9.2 CXP Link Configuration

The XML parameters related to the link configuration between the camera and CXP Frame Grabber are located in the CoaXPress category under the Transport Layer Control as shown below.

XML Parameters		Value	Description
CoaXPress	CxpLinkConfigurationPreferredSwitch	CXP6_X4	Sets the A parameter value to CXP6_X4.
		CXP6_X8	Sets the A parameter value to CXP6_X8.
	CxpLinkConfigurationPreferred ^A	Read Only	Displays bit rate and the number of connections to be set for the link configuration between the camera and Host (Frame Grabber) while discovering devices.
	CXPLinkConfiguration	CXP6_X4 CXP6_X8	Forcefully sets bit rate and the number of connections for the link configuration. ex) CXP6_X8: Eight connections running at a maximum of CXP6 speed (6.25 Gbps)

Table 9.4 XML Parameter related to CXP Link Configuration

9.3 Pixel Format

The camera processes image data in the unit of 10 bit internally. You can determine the format (8 bits or 10 bits) of these image data transmitted from the camera by selecting a pixel format. When the camera is set for 8 bit pixel format, the 2 least significant bits will be dropped from overall 10 bits.

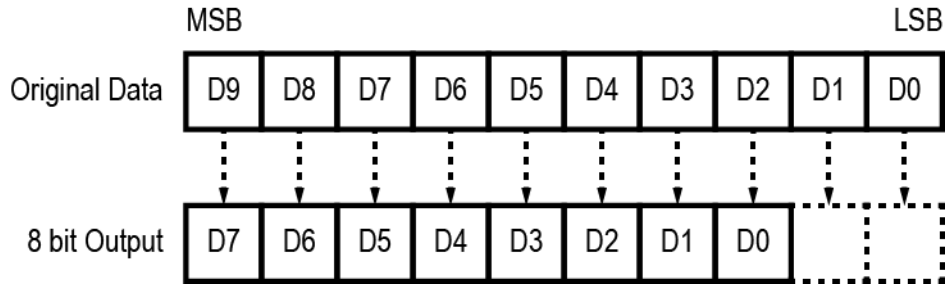

Figure 9.3 Pixel Format

The XML parameter related to the Pixel Format is as follows.

XML Parameters		Description
ImageFormatControl	PixelFormat	Sets the pixel format supported by the device.

Table 9.5 XML Parameter related to Pixel Format

The available pixel formats on the monochrome and color cameras are as follows.

Mono Sensor	Color Sensor
<ul style="list-style-type: none"> Mono 8 	<ul style="list-style-type: none"> Bayer GB 8 Bayer RG 8

Table 9.6 Pixel Format Values

9.4 Data ROI (Color Camera)

The **Balance White Auto** feature provided by the color camera uses the pixel data from a Data Region of Interest (ROI) to adjust the related parameters. The XML parameters related to Data ROI are as follows.

XML Parameters		Value	Description
DataRoiControl	RoiSelector	WhiteBalanceAuto	Selects a Data ROI used for Balance White Auto. <ul style="list-style-type: none"> Only available on color cameras
	RoiOffsetX	-	X coordinate of start point ROI
	RoiOffsetY	-	Y coordinate of start point ROI
	RoiWidth	-	Width of ROI
	RoiHeight	-	Height of ROI

Table 9.7 XML Parameters related to Data ROI

Only the pixel data from the area of overlap between the data ROI by your settings and the Image ROI will be effective if you use Image ROI and Data ROI at the same time. The effective ROI is determined as shown in the figure below.

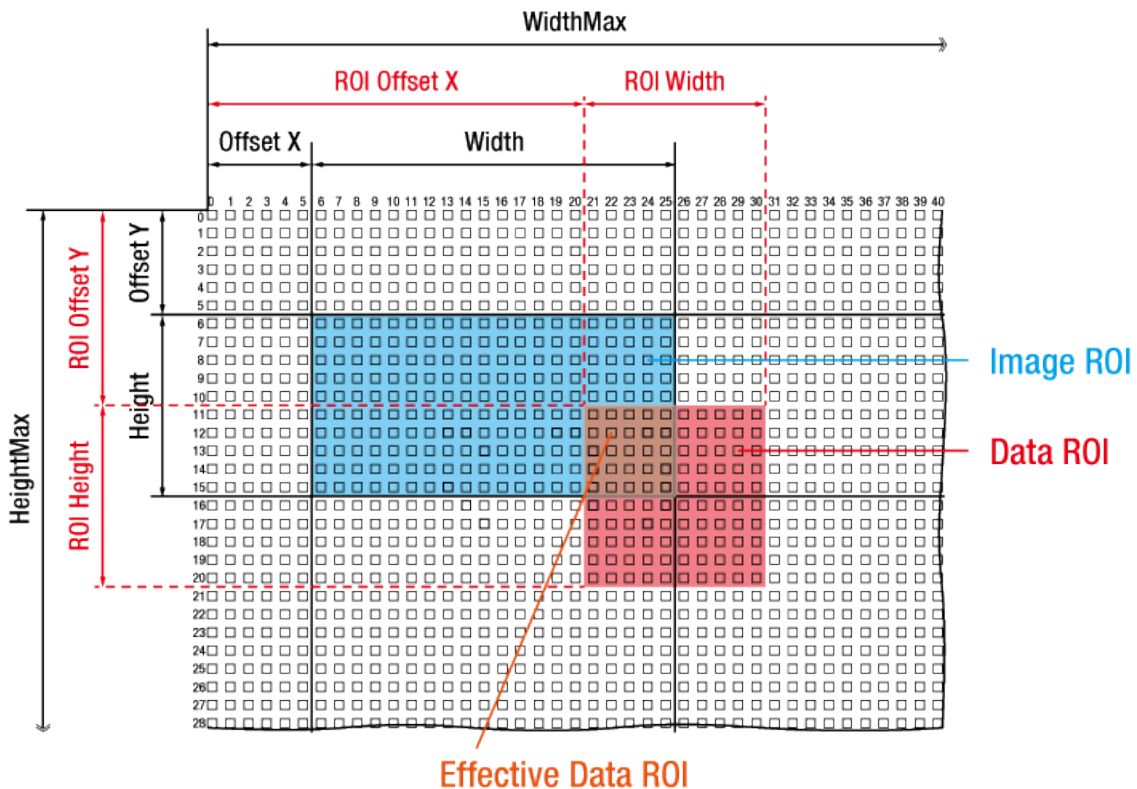

Figure 9.4 Effective Data ROI

9.5 White Balance (Color Camera)

The color cameras include the white balance capability to adjust the color balance of the images transmitted from the cameras. With the white balancing scheme used on the VC-12MX-330 F camera, the Red intensity and Blue intensity can be adjusted individually. You can set the intensity of each color by using the **Balance Ratio** parameter. The Balance Ratio value can range from 1.0 to 4.0. If the **Balance Ratio** parameter is set to 1.0 for a color, the intensity of the color will be unaffected by the white balance mechanism. If the **Balance Ratio** is set to greater than 1.0, the intensity of the color will be proportionally increased to the ratio. For example, if the Balance Ratio is set to 1.5, the intensity of that color will be increased by 50%.

The XML parameters related to White Balance are as follows.

XML Parameters		Value	Description
AnalogControl	BalanceRatioSelector	Red	A Balance Ratio value will be applied to red pixels.
		Blue	A Balance Ratio value will be applied to blue pixels.
	BalanceRatio	×1.0 ~ ×4.0	Controls ratio of the selected color by referring to Green.

Table 9.8 XML Parameters related to White Balance

9.5.1 Balance White Auto

The **Balance White Auto** feature is implemented on color cameras. It will control the white balance of the image acquired from the color camera according to the GeryWorld algorithm. Before using the **Balance White Auto** feature, you need to set the Data ROI for Balance White Auto. If you do not set the related Data ROI, the pixel data from the Image ROI will be used to control the white balance. As soon as the **Balance White Auto** parameter is set to **Once**, the Balance Ratio values for Red and Blue will be automatically adjusted to adjust the white balance by referring to Green. The XML parameters related to Balance White Auto are as follows.

XML Parameters		Value	Description
AnalogControl	BalanceWhiteAuto	Off	Balance White Auto Off
		Once	White Balance is adjusted once and then Off.

Table 9.9 XML Parameters related to Balance White Auto

9.6 Gain and Black Level

Increasing the **Gain** parameter increases the slope of the camera's response curve as shown in the figure below. This results in a higher grey value output from the camera for a given amount of output from the imaging sensor.

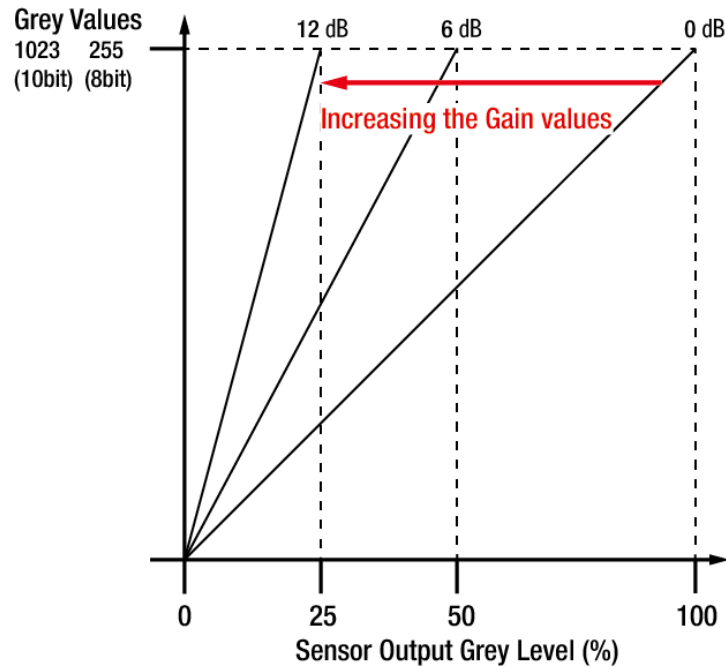

Figure 9.5 Setting the Gain

Adjusting the **Black Level** parameter will result in an offset to the pixel values output from the camera. The XML parameters related to Gain and Black Level are as follows.

XML Parameters	Value	Description	
AnalogControl	GainSelector	DigitalAll	Applies gain to all digital channels.
	Gain	1.0×~4.0×	Sets an absolute physical gain value (0 dB ~ 12 dB).
	BlackLevelSelector	DigitalAll	Applies black level to all digital channels.
	BlackLevel	0~16 0~64	Sets an absolute physical black level value. • 0 ~ 16 LSB @ 8 bit

Table 9.10 XML Parameters related to Gain and Black Level

9.7 Defective Pixel Correction

The CMOS sensor may have Defect Pixels which cannot properly react to the light. Correction is required since it may deteriorate the quality of output image. Defect Pixel information of CMOS used for each camera is entered into the camera during the manufacturing process. If you want to add Defect Pixel information, it is required to enter coordinate of new Defect Pixel into the camera. For more information, refer to [Appendix A](#).

9.7.1 Correction Method

Correction value for Defect Pixel is calculated based on valid pixel value adjacent in the same line.

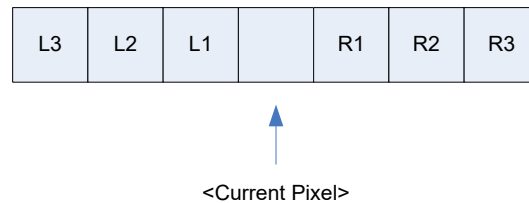

Figure 9.6 Location of Defect Pixel to be corrected

If Current Pixel is a Defect Pixel as shown in the above figure, correction value of this pixel is obtained as shown in the following table depending on whether surrounding pixel is Defect Pixel or not.

Adjacent Defect Pixel (s)	Correction Value of Current Pixel
None	$(L1 + R1) / 2$
L1	R1
R1	L1
L1, R1	$(L2 + R2) / 2$
L1, R1, R2	L2
L2, L1, R1	R2
L2, L1, R1, R2	$(L3 + R3) / 2$
L2, L1, R1, R2, R3	L3
L3, L2, L1, R1, R2	R3

Table 9.11 Calculation of Defect Pixel Correction Value



You must download a Defect Pixel Map to the camera before using the **Defective Pixel Correction** feature. For more information about how to download a Defect Pixel Map to the camera, refer to [Appendix A](#).

9.8 Flat Field Correction

The **Flat Field Correction** feature improves the image uniformity when you acquire a non-uniformity image due to external conditions. The Flat Field Correction feature can be summarized by the following equation:

$$IC = IR / IF$$
 Where,
 IC : Level value of corrected image;
 IR : Level value of original image;
 IF : Level value of Flat Field data.

In actual use conditions, generate a Flat Field data (IF) and apply the Flat Field Correction feature according to the following procedures.

1. Execute the **Ffc Generate** parameter.
After executing the **Ffc Generate** parameter, you must acquire one image to generate the scaled-down Flat Filed data.
2. Execute the **Ffc Save** parameter to save the generated Flat Field data into the non-volatile memory.
When the scaled-down Flat Field data are used for corrections, they are expanded and applied with a Bilinear Interpolation as shown in the Figure 9.8.
3. Set the **Ffc Mode** parameter to **On** to apply the Flat Field data to the camera.



- It is recommended that you enable the **Defective Pixel Correction** feature before executing the **Ffc Generate** parameter.
- Before executing the **Ffc Generate** parameter, you must set the camera as follows:
 - OffsetX, Y: 0
 - Width, Height: Maximum values
 - Binning: ×1
- After executing an **Acquisition Start** command, you need to operate the camera with free-run mode or apply a trigger signal to acquire an image.

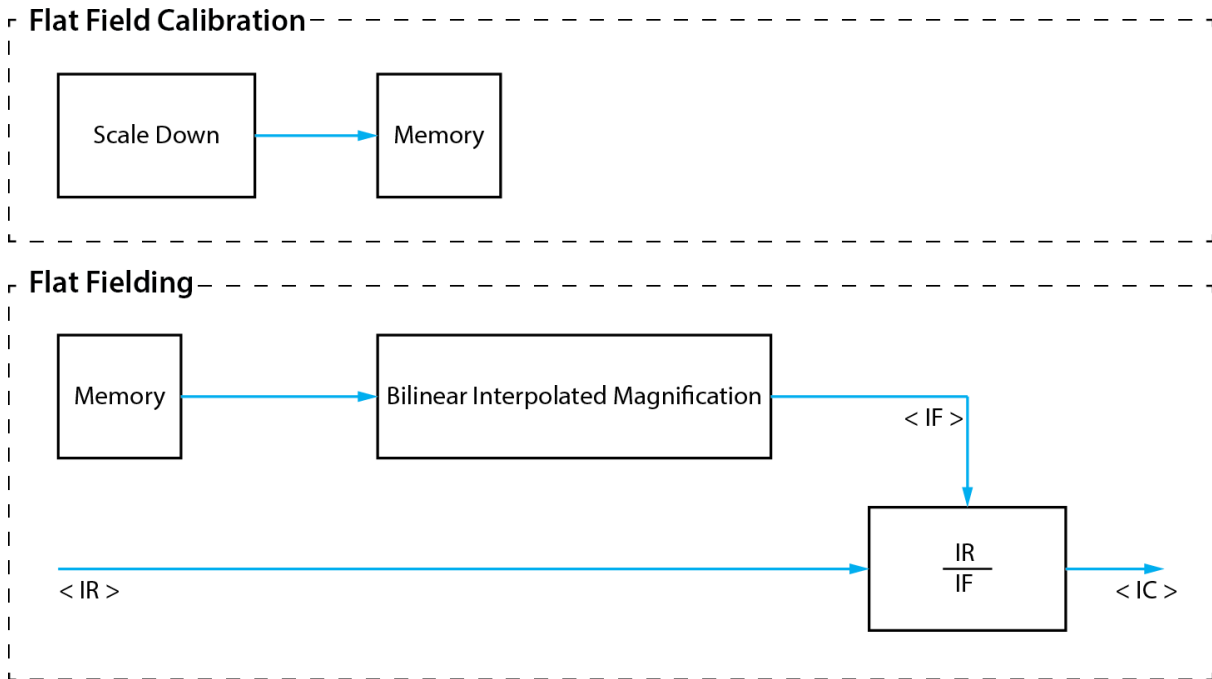

Figure 9.7 Generation and Application of Flat Field Data

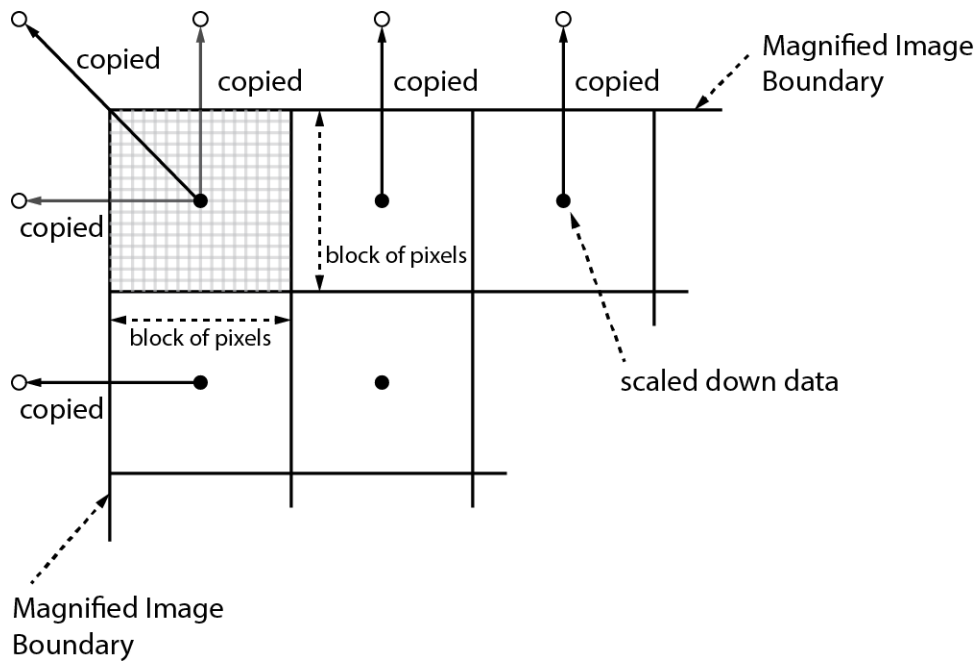

Figure 9.8 Bilinear Interpolated Magnification

The XML parameters related to Flat Field Correction are as follows.

XML Parameters		Value	Description
FlatFieldCorrection	FfcMode	Off	Flat Field Correction Off
		On	Enables the Flat Field Correction feature.
	FfcGenerate	-	Generates the Flat Field data.
	FfcSave	-	Saves the generated Flat Field data in the non-volatile memory. <ul style="list-style-type: none"> The generated data by executing the FfcGenerate command are saved in the volatile memory so that the data are lost if the camera is reset or if power is turned off. To use the data after the camera is powered on or reset, save them in the non-volatile memory.
FfcLoad	-	Loads the Flat Field data from the non-volatile memory into volatile memory.	

Table 9.12 XML Parameters related to Flat Field Correction

9.9 High Dynamic Range

When you acquire images in some situations where a bright light source or shiny materials are located within the field of view, the light areas appear overexposed in the acquired images. And if you use a short exposure time to avoid overexposure in the light areas of the acquired images, all details will be lost in the darker areas.

The Multiple Slope capability is implemented on VC-12MX camera to acquire high dynamic range (HDR) images which have higher variations between the brightest and darkest portions of the images. As shown in the figure below, when the bright pixel reaches a certain output level, it will be maintained at the level for a programmable time from overall exposure time. This happens two times to make sure that the pixel is not saturated at the end of exposure time.

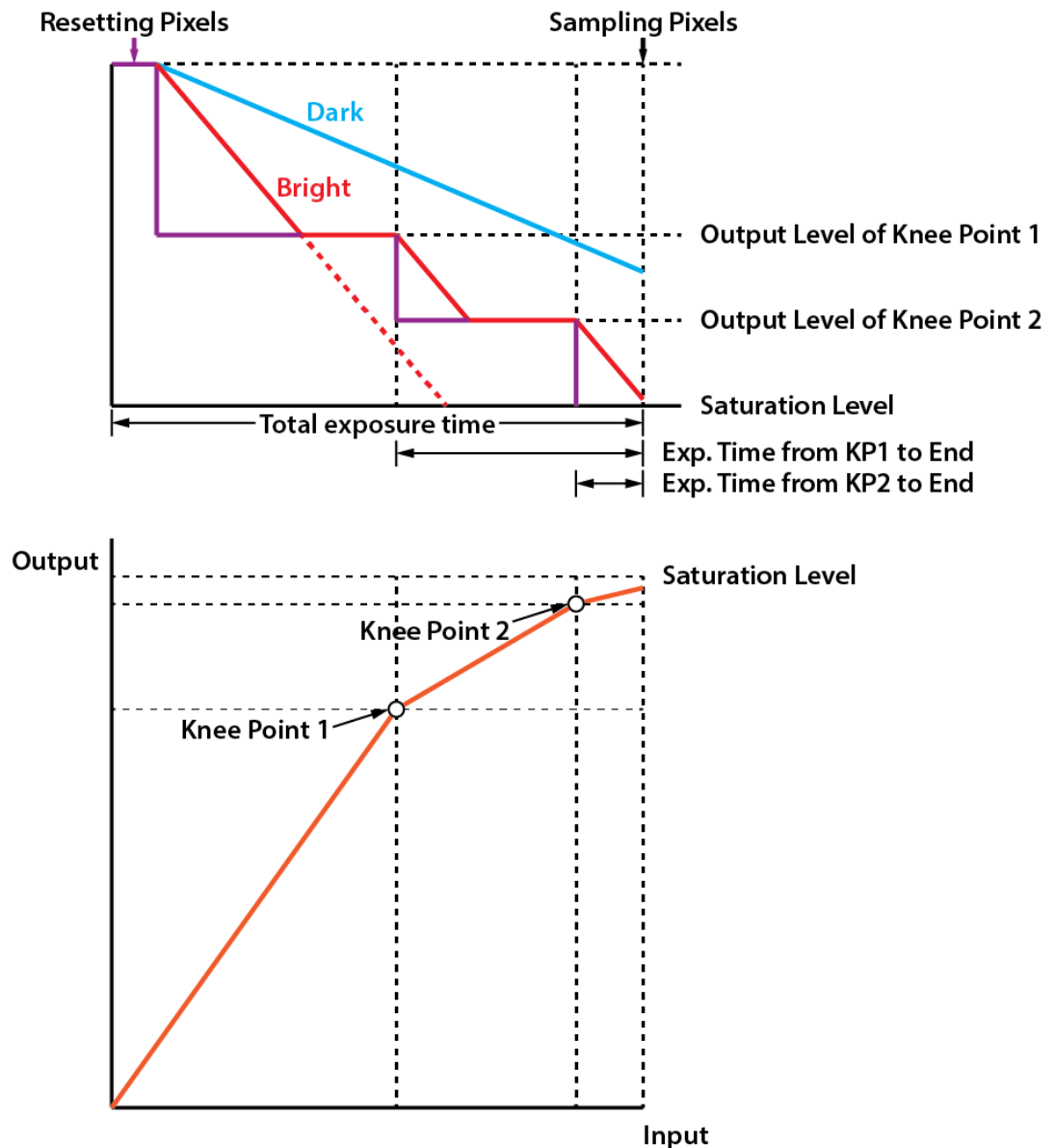

Figure 9.9 High Dynamic Range Concept Drawing

To use the HDR feature, set the **Exposure Mode** parameter to **Timed** and then set the parameters related to the HDR feature. The XML parameters related to HDR are as follows.

XML Parameters		Value	Description
HDRControl	HDRMode	Off	High Dynamic Range Off
		On	Enables the HDR feature.
	HDRDB	0 ~ 40 dB	Sets the dynamic range to increase in dB. <ul style="list-style-type: none"> The exposure time for both Knee Point 1 and Knee Point 2 will be automatically optimized by setting a HDRDB value.

Table 9.13 XML Parameters related to HDR Control

9.10 Temperature Monitor

The camera has an embedded sensor chip to monitor the internal temperature.

The XML parameter related to Device Temperature is as follows.

XML Parameters		Description
DeviceControl	DeviceTemperature	Displays device temperature in Celsius.

Table 9.14 XML Parameter related to Device Temperature

9.11 Status LED

A LED is installed on the back panel of the camera to inform the operation status of the camera. LED status and corresponding camera status are as follows:

Status LED	Description
Steady Red	The camera is not initialized.
Slow Flashing Red	A CXP Link is not configured.
Fast Flashing Orange	The camera is checking a CXP Link configuration.
Steady Green	A CXP Link is configured.
Fast Flashing Green	The camera is transmitting image data.

Table 9.15 Status LED

9.12 Test Pattern

To check normal operation of the camera, it can be set to output test patterns created inside, instead of image data from the imaging sensor. There are four types of test pattern; image with different value in horizontal direction (Grey Horizontal Ramp), image with different value in diagonal direction (Grey Diagonal Ramp), moving image with different value in diagonal direction (Grey Diagonal Ramp Moving), and image with different value in horizontal direction output from the imaging sensor (Grey Diagonal Ramp_2).

The XML parameters related to Test Pattern are as follows.

XML Parameters		Value	Description
ImageFormatControl	TestPattern	Off	Test Pattern Off
		GreyHorizontalRamp	Sets to Grey Horizontal Ramp.
		GreyDiagonalRamp	Sets to Grey Diagonal Ramp.
		GreyDiagonalRampMoving	Sets to Grey Diagonal Ramp Moving.
		GreyHorizontalRamp_2	Sets to Grey Horizontal Ramp_2.

Table 9.16 XML Parameter related to Test Pattern

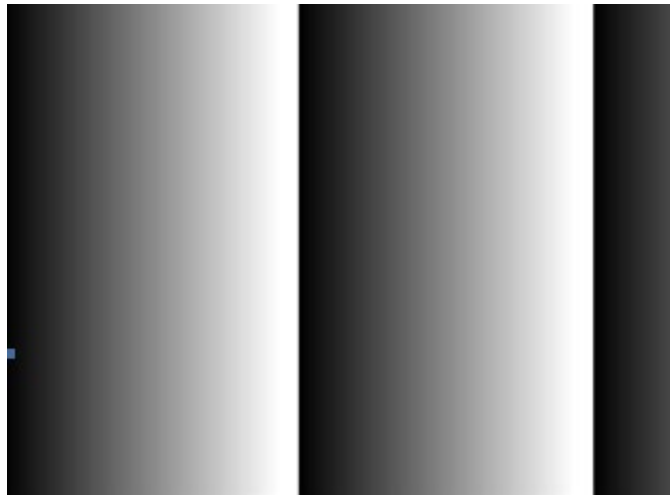

Figure 9.10 Grey Horizontal Ramp

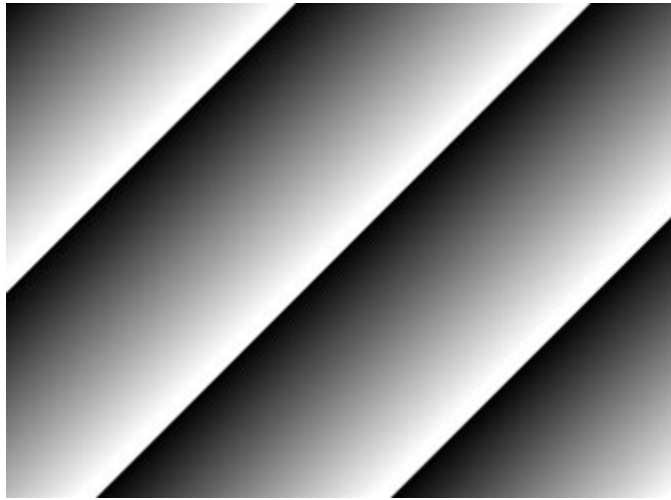

Figure 9.11 Grey Diagonal Ramp



Figure 9.12 Grey Diagonal Ramp Moving

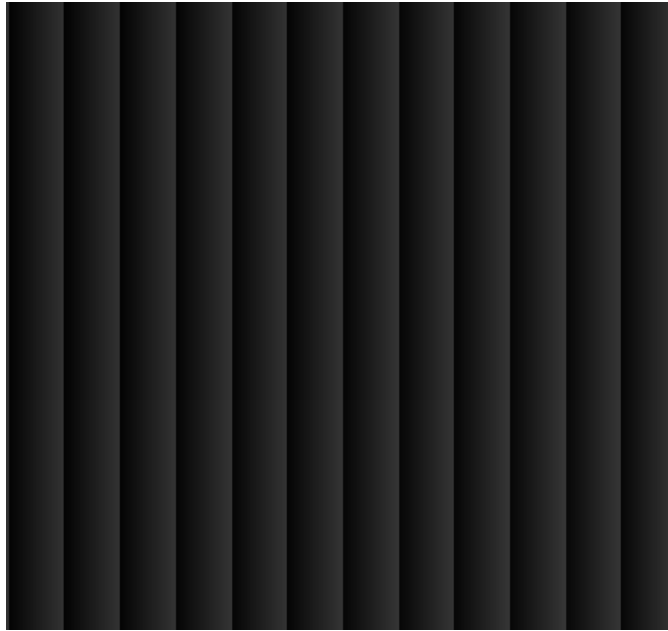

Figure 9.13 Grey Horizontal Ramp_2



The test pattern may look different because the region of the test pattern may vary depending on the camera's resolution.

9.13 Reverse X

The Reverse X feature lets you flip images horizontally. This feature is available in all operation modes of the camera. The XML parameter related to Reverse X is as follows.

XML Parameters		Value	Description
ImageFormatControl	ReverseX	FALSE	Disables the Reverse X feature.
		TRUE	Flips images horizontally.

Table 9.17 XML Parameter related to Reverse X



Figure 9.14 Original Image

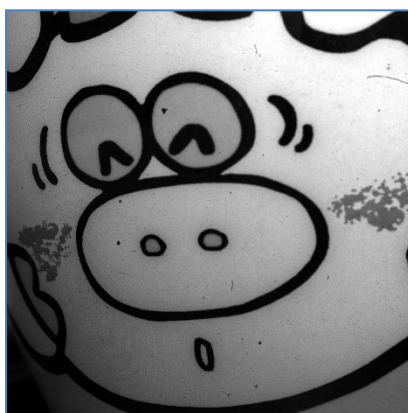

Figure 9.15 Reverse X Image

9.14 Digital IO Control

The control I/O receptacle of the camera is designated as programmable output and can be operated in various modes.

The XML parameters related to Digital IO Control are as follows.

XML Parameters	Value	Description	
DigitalIOControl	LineSelector	LineIn0	Selects the number 1 pin of the camera's control I/O receptacle as an input line.
		LineOut0	Selects the number 4 pin of the camera's control I/O receptacle as an output line.
	LineInverter	On	Enables inversion on the output signal of the line.
		Off	Disables inversion on the output signal of the line.
	Line Source	Off	Disables the line output.
		Frame Active	Outputs pulse signals indicating a frame readout time
		Strobe Out	Outputs pulse signal indicating the current exposure time with Strobe Out Delay
		User Output	Outputs pulse signals set by User Output Value.
	UserOutputValue	On	Set the bit state of the line to High
		Off	Set the bit state of the line to Low
	StrobeOutDelay	0 ~ 65535	Set a delay in microseconds when the Line Source is set to Strobe Out

Table 9.18 Digital IO Control

The camera can provide a **Strobe Out** output signal. The signal goes high when the exposure time for each frame acquisition begins and goes low when the exposure time ends as shown in the figure below. This signal can be used as a flash trigger and is also useful when you are operating a system where either the camera or the object being imaged is movable. Typically, you do not want the camera to move during exposure. You can monitor the **Strobe Out** signal to know when exposure is taking place and thus know when to avoid moving the camera.

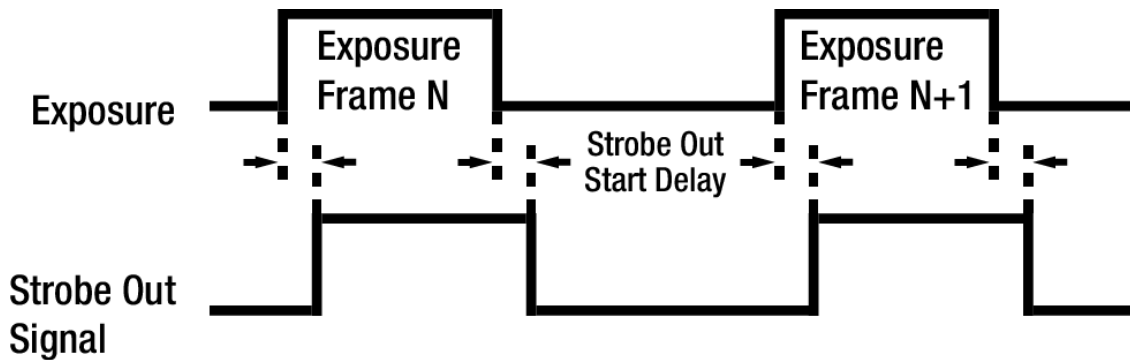

Figure 9.16 Strobe Out Signal



When you use the Strobe Out signal, be aware that there is a Strobe Out Start Delay as shown in the Table 9.16.

Camera Model	Strobe Out Start Delay
VC-12MX-330 F	$\leq 0.8 \mu s$

Table 9.19 Strobe Out Start Delay

9.15 Fan Control

A fan is installed on the rear panel of the camera to radiate heat. You can set the fan to turn on or off. You can also set the fan to turn on when a specified internal temperature is reached. The XML parameters related to Fan Control are as follows.

XML Parameters		Value	Description
FanControl	FanOperationMode	Off	Turns off the fan.
		On	Turns on the fan.
		Temperature	Turns on the fan when the internal temperature exceeds the value set in the Fan Operation Temperature parameter.
	FanOperationTemperature	-10°C~80°C	Set the temperature to operate the fan when the Fan Operation Mode parameter is set to Temperature .
FanSpeed	-	Verifies the current Fan RPM.	

Table 9.20 XML Parameters related to Fan Control

9.16 Device User ID

You can input user defined information up to 16 bytes.

The XML parameter related to Device User ID is as follows.

XML Parameters		Description
DeviceControl	DeviceUserID	Inputs user defined information (16 bytes).

Table 9.21 XML Parameter related to Device User ID

9.17 Device Reset

Reset the camera physically to power off and on. You must configure a link again because the camera will be released from the link between the camera and CXP Frame Grabber after reset. The XML parameter related to Device Reset is as follows.

XML Parameters		Description
DeviceControl	DeviceReset	Resets the camera physically.

Table 9.22 XML Parameter related to Device Reset

9.18 User Set Control

You can save the current camera settings to the camera's internal ROM. You can also load the camera settings from the camera's internal ROM. The camera provides two setups to save and three setups to load settings. The XML parameters related to User Set Control are as follows.

XML Parameters		Value	Description
UserSetControl	UserSetSelector	Default	Selects the Factory Default settings.
		UserSet1	Selects the User Set1 settings.
		UserSet2	Selects the User Set2 settings.
	UserSetLoad	-	Loads the User Set specified by User Set Selector to the camera.
	UserSetSave	-	Saves the current settings to the User Set specified by User Set Selector. <ul style="list-style-type: none"> The Default is a Factory Default Settings and allowed to load only.
	UserSetDefault	Default	Applies the Factory Default settings when reset.
		UserSet1	Applies the User Set1 settings when reset.
		UserSet2	Applies the User Set1 settings when reset.

Table 9.23 XML Parameters related to User Set Control

9.19 Field Upgrade

The camera provides a feature to upgrade Firmware and FGPA logic through CoaXPress interface rather than disassemble the camera in the field. Refer to [Appendix B](#) for more details on how to upgrade.

10 Troubleshooting

When you have a problem with a Vieworks camera, please check the following items.

- If no image is displayed on your computer,
 - Ensure that all the cable connections are secure.
 - Ensure that the power supply is properly connected.
 - Ensure that trigger signal is applied correctly when you set the Trigger Mode parameter to On.

- If images are not clear,
 - Ensure the camera lens or glass is clean.
 - Check the lens aperture is adjusted properly.

- If images are dark,
 - Ensure your camera lens is not blocked.
 - Check the exposure time is set properly.
 - Check the aperture is opened properly.
 - Check the Gain value is not set too small.

- If you identify abnormal operation or overheating sign,
 - Ensure the power supply is properly connected.
 - Stop using the camera when you notice smoke or abnormal overheating.

- If you have a problem using the Trigger Mode,
 - Ensure that the trigger related parameters on your CXP Frame Grabber are configured correctly when you set the Trigger Source parameter to CXPin.
 - Ensure that cable connections are secure when you set the Trigger Source parameter to LineIn0.

- If there is a communication failure between the camera and computer,
 - Ensure coax cables are connected properly.
 - Ensure that you have configured a CXP Frame Grabber in your computer correctly and the camera is connected properly to the CXP Frame Grabber.

Appendix A Defect Pixel Map Download

1. Create the Defect Pixel Map data in Microsoft Excel format as shown in the left picture below and save as a CSV file (*.csv). The picture in the right shows the created Excel file opened in Notepad. The following rules need to be applied when creating the file.
 - Lines beginning with ':' or '--' are treated as notes.
 - Each row is produced in the order of the horizontal and vertical coordinate values.
 - The input sequence of pixel is irrelevant.

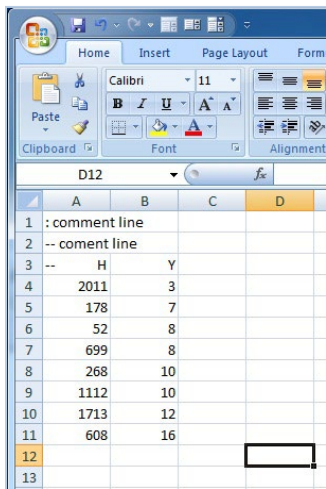

	A	B	C	D
1	:	comment line		
2	--	comment line		
3	--	H	Y	
4		2011	3	
5		178	7	
6		52	8	
7		699	8	
8		268	10	
9		1112	10	
10		1713	12	
11		608	16	
12				
13				

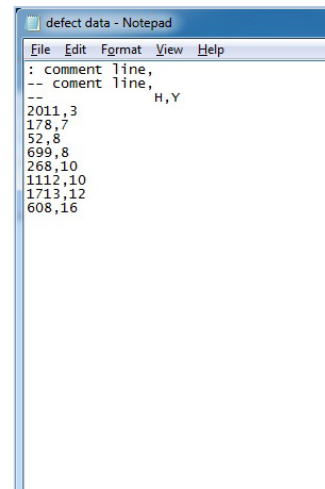

```
defect data - Notepad
File Edit Format View Help
: comment line,
-- comment line,
--
2011,3
178,7
52,8
699,8
268,10
1112,10
1713,12
608,16
```

2. Run Vieworks Imaging Solution 7.X and click the **Configure** button to display the window as shown below. Select the **Defect** tab, click the File Path button, search and select the defect pixel map file (*.csv), and then click the **Download** button.

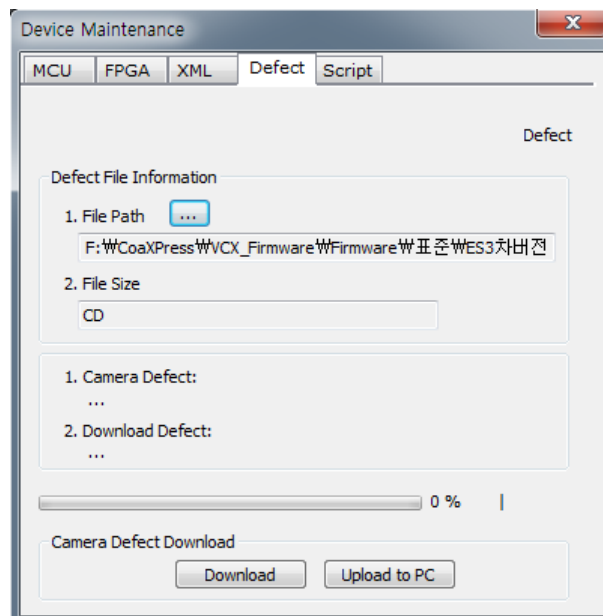

- Once the download is complete, the saving process will begin. During the saving process, make sure not to disconnect the power cord.

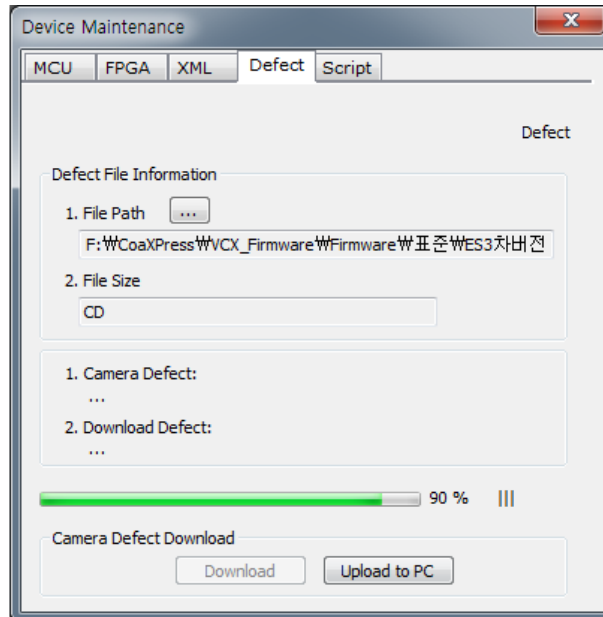

- After completing the download, click the **OK** button to close the confirmation.

Appendix B Field Upgrade

B.1 MCU

1. Run Vieworks Imaging Solution 7.X and click the **Configure** button to display the window as shown below.
2. Select the **MCU** tab, click the File Path button, search and select the MCU upgrade file, and then click the **Download** button.

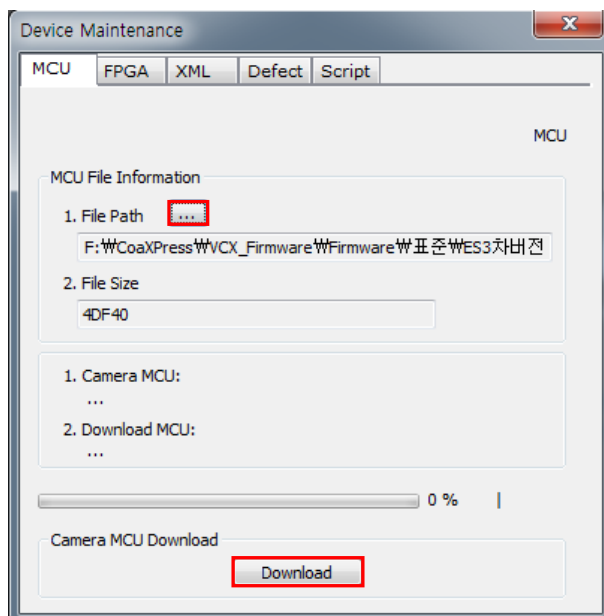

3. MCU upgrade file download starts and the downloading status is displayed at the bottom of the window.

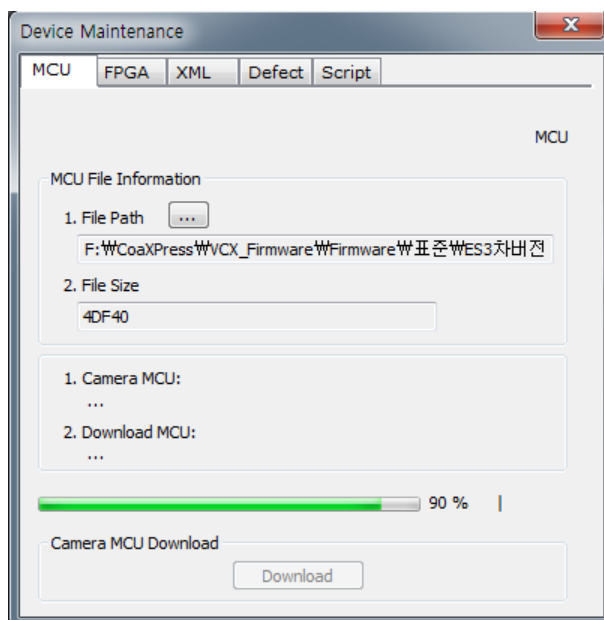

- Once all the processes have been completed, turn the camera power off and turn it back on again.
Check the Device Version parameter value to confirm the version.

DeviceControl	
DeviceScanType	Areascan
DeviceVendorName	VIEWWORKS
DeviceModelName	VC-12MX-C180
DeviceManufacturerInfo	
DeviceVersion	M:0.4.4 F:1.1.1
DeviceSerialNumber	Z9-ECMADW001

B.2 FPGA

1. Run Vieworks Imaging Solution 7.X and click the **Configure** button to display the window as shown below.
2. Select the **FPGA** tab, click the File Path button, search and select the FPGA upgrade file, and then click the **Download** button.

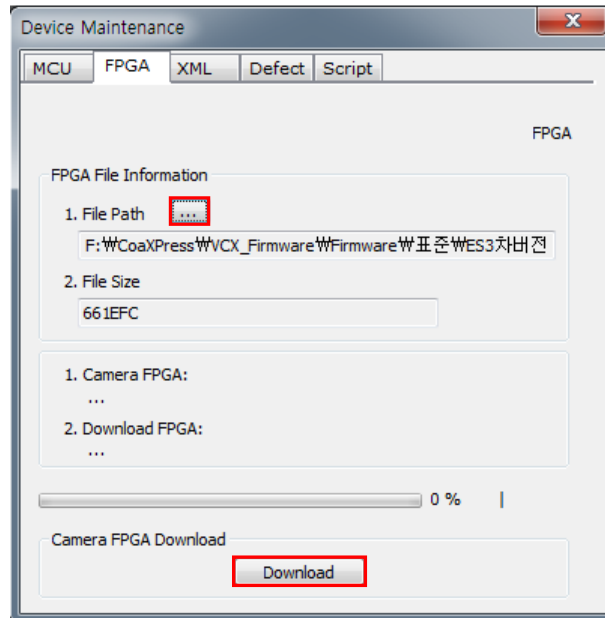

3. The subsequent processes are identical to those of MCU upgrade.

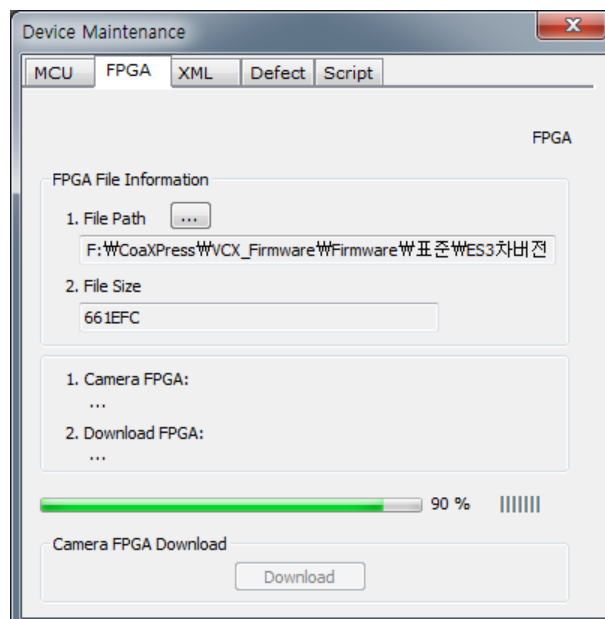

B.3 XML

1. Run Vieworks Imaging Solution 7.X and click the **Configure** button to display the window as shown below.
2. Select the **XML** tab, click the File Path button, search and select the XML upgrade file, and then click the **Download** button.

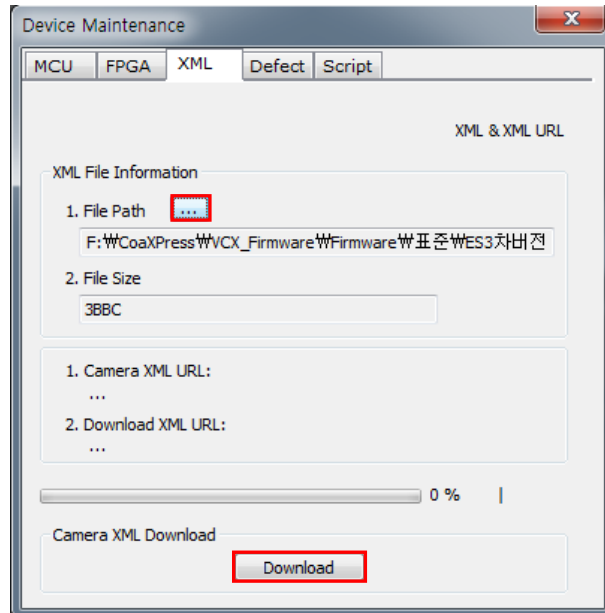

3. The subsequent processes are identical to those of MCU upgrade.

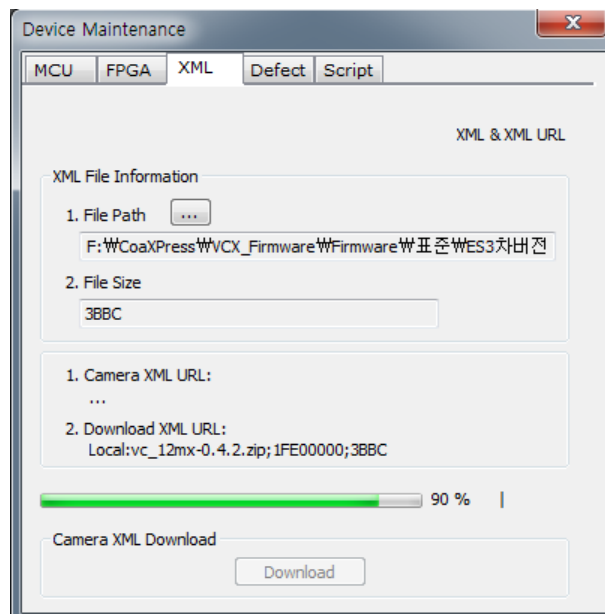

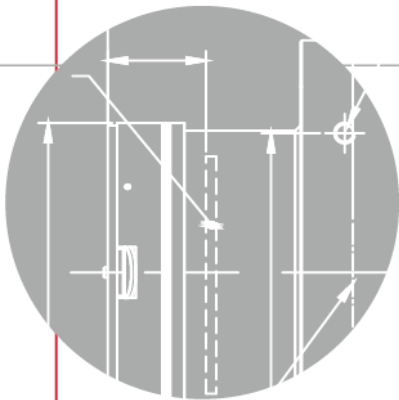
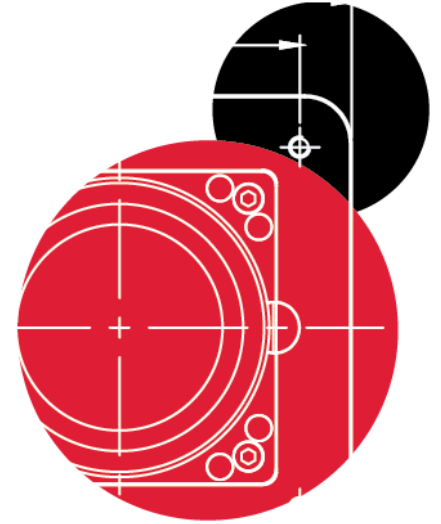
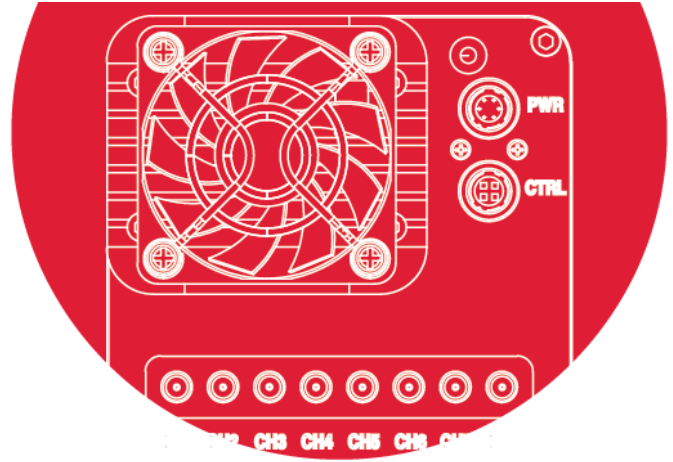

Vieworks Co., Ltd.

41-3, Burim-ro, 170beon-gil,
Dongan-gu, Anyang-si, Gyeonggi-do
14055 Republic of Korea

Tel: +82-70-7011-6161 Fax: +82-31-386-8631

<http://vision.vieworks.com>

vision@vieworks.com