

VIEWWORKS

VC Series User Manual

VC-21MDF-M/C460I, VC-21MDF-M/C 460I-HS



CoaxPress®

© 2024 Vieworks. All rights reserved.

The copyright of this document belongs to Vieworks Co., Ltd., and in accordance with copyright law, all or part of this document may not be copied, reprinted, or extracted without the permission of Vieworks Co., Ltd. Specifications and related information in this document may change without notice. Please refer to the latest version of the manual on the download website provided by our company. (<http://vision.vieworks.com>)

Preface

No part of this manual may either be copied, reproduced, translated, or published in any form or by any means (electronic, mechanical, photocopying, or otherwise) without the express written permission of Vieworks, Co., Ltd. (hereinafter 'Vieworks').

This manual may include the website links to companies other than Vieworks. Vieworks is not responsible for any of these links. The copyrights of the materials mentioned herein are owned by each respective author.

Although Vieworks made every effort to ensure the accuracy of this document, it assumes no responsibility for errors or omissions that may appear herein. The figures in this manual may differ depending on the version of the product or operating system, or the way how it runs. Information in this manual is subject to change without notice.

Before Using This Product

Thank you for choosing VC-21MDF-M/C460I™.

- Make sure to read this manual before using the product.
- Make sure to check whatever a professional engineer has finished installation and configuration.
- Make sure to keep this manual at hand as a reference while using the product.
- This manual assumes that you have expertise in how to use an industrial camera.

The Series

This manual is intended for users of the following products:

- VC-21MDF-M/C460I

About This Manual

This manual is intended for VC-21MDF-M/C460I™ camera users. It is recommended to refer to the Frame Grabber's User Manual of yours, with this manual.

Convention in This Manual

For better understanding, the following conventions are used throughout the manual.

Names and Fonts

The names and fonts of user interfaces are used as follows:

- The menu and icon names in this manual are used as displayed in the product.

Warning, Caution, and Note

This manual shows warnings, cautions, and notes with the following figures:

**Warning!**

This indicates that you need to follow this message for your safety and to prevent the product from damage.

**Caution!**

This indicates that you need to follow this message to prevent data from being lost or corrupted.

**Note:**

This indicates that this message provides additional information.

Definition of Terms

For clarity, this manual defines some terms as follows:

| Term | Definition |
|---------------------------------|---|
| Preface | The introductory part preceding the Table of Contents in this manual |
| Vieworks Imaging Solution (VIS) | Indicates the control software provided with the product together by Vieworks (VIS) |
| CoF | Indicates abbreviation of Interface CoaXPress-over-Fiber |
| Single channel | Indicates channel 1 of the CoF interface, "CoF channel 1" described in Figure 5-1 |
| Dual channel | Indicates channel 2 of the CoF interface, "CoF channel 2" described in Figure 5-1 |

Revision History

This document has the revision history as follows:

| Version | Date | Description |
|---------|------------|---|
| 1.0 | 2023-12-28 | Initial release |
| 1.1 | 2024-03-12 | Added) References of partial shutdown in chapter 9.21 Temperature Monitor Added) LED Status in chapter 9.22 related to partial shutdown function |
| 1.2 | 2024-06-05 | Modified) Chapter 7.3 Power Input and Control I/O Receptacle |
| 1.3 | 2024-07-16 | Added a note about power connections in Chapter 7.3 |

Contents

| | |
|---|-----------|
| Chapter 1. Precautions | 15 |
| Chapter 2. Warranty Coverage..... | 17 |
| Chapter 3. Compliance & Certifications | 18 |
| 3.1 FCC Compliance..... | 18 |
| 3.2 CE : DoC..... | 18 |
| 3.3 KC | 18 |
| Chapter 4. Package Components..... | 19 |
| 4.1 Included Components..... | 19 |
| 4.2 Additional Components | 20 |
| 4.2.1 Frame Grabbers..... | 20 |
| 4.2.2 Fiber-optic Cables | 21 |
| 4.2.3 Transceivers | 21 |
| Chapter 5. Product Specifications..... | 22 |
| 5.1 Overview | 22 |
| 5.2 Specifications | 23 |
| 5.3 Camera Block Diagram | 24 |
| 5.4 Spectral Response | 25 |
| 5.5 Mechanical Specification | 26 |
| 5.5.1 Camera Mounting and Heat Dissipation | 27 |
| Chapter 6. Connecting the Camera..... | 28 |
| 6.1 Connecting the Camera and Other Components..... | 28 |
| 6.2 Setting Up the Driver for Frame Grabbers..... | 30 |
| 6.3 Configuring Channels | 31 |
| 6.3.1 Configuring Single-channel Mode..... | 31 |
| 6.3.2 Configuring Dual-channel Mode..... | 31 |
| 6.4 Changing ROI by Channel | 32 |
| 6.4.1 Setting ROI in Single-channel Mode | 32 |
| 6.4.2 Setting ROI in Dual-channel Mode | 32 |

| | | |
|--|---|-----------|
| 6.5 | Installing Vieworks Imaging Solution | 33 |
| Chapter 7. Camera Interface..... | | 34 |
| 7.1 | General Description..... | 34 |
| 7.2 | CoaXPress-over-Fiber Connector | 35 |
| 7.2.1 | CoF Connector | 35 |
| 7.2.2 | MPO Cable's Connector | 36 |
| 7.3 | Power Input and Control I/O Receptacle | 37 |
| 7.4 | Trigger Input Circuit..... | 38 |
| 7.5 | Strobe Output Circuit | 38 |
| Chapter 8. Acquisition Control..... | | 39 |
| 8.1 | Overview | 39 |
| 8.2 | Acquisition Start/Stop Commands and Acquisition Mode..... | 40 |
| 8.2.1 | Acquisition Start/Stop Commands..... | 40 |
| 8.2.2 | Acquisition Mode..... | 40 |
| 8.2.3 | Exposure Start Trigger | 41 |
| 8.2.4 | Applying Trigger Signals | 42 |
| 8.2.5 | Exposure Time Control..... | 43 |
| 8.3 | Exposure Start Trigger | 43 |
| 8.3.1 | Trigger Mode | 43 |
| 8.3.2 | Using a Software Trigger Signal..... | 47 |
| 8.3.3 | Using a CoaXPress Trigger Signal..... | 48 |
| 8.3.4 | Using an External Trigger Signal | 49 |
| 8.3.5 | Exposure Mode | 51 |
| 8.4 | Overlapping Exposure with Sensor Readout | 53 |
| 8.5 | Global Shutter | 55 |
| 8.6 | Maximum Allowed Frame Rate..... | 56 |
| 8.6.1 | Increasing the Maximum Allowed Frame Rate | 57 |
| Chapter 9. Camera Features..... | | 58 |

| | | |
|------|---|----|
| 9.1 | Sequence of Signal Processing | 58 |
| 9.2 | Region of Interest | 59 |
| 9.3 | Binning..... | 63 |
| 9.4 | CoF Link Sharing Control | 65 |
| 9.5 | Pixel Format..... | 67 |
| 9.6 | Device Tap Geometry..... | 68 |
| 9.7 | Data ROI (Color Only) | 70 |
| 9.8 | White Balance (Color Only)..... | 71 |
| | 9.8.1 Balance White Auto | 71 |
| 9.9 | Gain and Black Level | 72 |
| 9.10 | Defective Pixel Correction | 73 |
| | 9.10.1 Correction Method..... | 73 |
| 9.11 | Dark Signal Non-uniformity Correction..... | 74 |
| | 9.11.1 Generating and Saving User DSNU Correction Values..... | 75 |
| 9.12 | Photo Response Non-uniformity Correction | 76 |
| | 9.12.1 Generating and Saving User PRNU Correction Values..... | 77 |
| 9.13 | Flat Field Correction..... | 78 |
| | 9.13.1 Flat Field Data Selector | 81 |
| 9.14 | Timestamp..... | 82 |
| 9.15 | Event Control..... | 83 |
| 9.16 | Digital I/O Control | 84 |
| 9.17 | Debounce..... | 86 |
| 9.18 | Counter Control | 87 |
| 9.19 | Timer Control | 89 |
| 9.20 | Cooling Control..... | 90 |
| 9.21 | Temperature Monitor..... | 91 |
| 9.22 | Status LED | 91 |
| 9.23 | Test Pattern | 92 |
| 9.24 | Reverse X..... | 94 |
| 9.25 | Device Link Throughput Limit..... | 95 |
| 9.26 | Device User ID | 95 |

| | | |
|---|-------------------------|------------|
| 9.27 | Device Reset | 95 |
| 9.28 | Field Upgrade | 96 |
| 9.29 | User Set Control | 96 |
| 9.30 | Sequencer Control | 97 |
| Chapter 10. Troubleshooting..... | | 102 |
| Appendix A. Defective Pixel Map Download | | 103 |
| Appendix B. Field Upgrade..... | | 104 |

Tables

| | | |
|------------|---|----|
| Table 5-1 | Specifications VC-21MDF-M/C460I | 23 |
| Table 7-1 | Channel Assignments for CoF Connector..... | 35 |
| Table 7-2 | Pin Configurations for 12-fiber MPO Connector | 36 |
| Table 7-3 | Pin Configurations for Power Input and Control I/O Receptacle | 37 |
| Table 9-1 | XML Parameters related to ROI | 60 |
| Table 9-2 | Minimum ROI Width and Height Settings..... | 60 |
| Table 9-3 | XML Parameters related to LineWidth | 61 |
| Table 9-4 | Maximum Frame Rates by VC-21MDF-M/C460I ROI Changes_CXP-12x1 | 61 |
| Table 9-5 | Maximum Frame Rates by VC-21MDF-M/C460I ROI Changes_CXP-12x2 | 62 |
| Table 9-6 | Maximum Frame Rates by VC-21MDF-M/C460I ROI Changes_CXP-12x4 | 62 |
| Table 9-7 | XML Parameters related to Binning | 63 |
| Table 9-8 | XML Parameters related to CoF Link Configuration | 66 |
| Table 9-9 | XML Parameter related to Pixel Format | 67 |
| Table 9-10 | Pixel Format Values | 67 |
| Table 9-11 | Tap Geometry Properties | 68 |
| Table 9-12 | XML Parameters related to Geometry..... | 69 |

| | | |
|------------|--|----|
| Table 9-13 | XML Parameters related to Data ROI..... | 70 |
| Table 9-14 | XML Parameters related to White Balance..... | 71 |
| Table 9-15 | XML Parameter related to Balance White Auto..... | 71 |
| Table 9-16 | XML Parameters related to Gain and Black Level..... | 72 |
| Table 9-17 | Calculation of Defect Pixel Correction Value..... | 73 |
| Table 9-18 | XML Parameters related to DSNU..... | 74 |
| Table 9-19 | XML Parameters related to PRNU..... | 76 |
| Table 9-20 | XML Parameters related to Flat Field Correction..... | 80 |
| Table 9-21 | XML Parameters related to Timestamp..... | 82 |
| Table 9-22 | XML Parameters related to Event Control..... | 83 |
| Table 9-23 | XML Parameters related to Digital I/O Control..... | 84 |
| Table 9-24 | XML Parameter related to Debounce Time..... | 86 |
| Table 9-25 | XML Parameters related to Counter Control #1..... | 87 |
| Table 9-26 | XML Parameters related to Counter Control #2..... | 88 |
| Table 9-27 | XML Parameters related to Timer Control..... | 89 |
| Table 9-28 | XML Parameters related to Cooling Control..... | 90 |
| Table 9-29 | XML Parameters related to Device Temperature..... | 91 |
| Table 9-30 | Status LED..... | 91 |
| Table 9-31 | XML Parameter related to Test Pattern..... | 92 |
| Table 9-32 | XML Parameter related to Reverse X..... | 94 |
| Table 9-33 | XML Parameter related to Device Link Throughput Limit..... | 95 |
| Table 9-34 | XML Parameter related to Device User ID..... | 95 |
| Table 9-35 | XML Parameter related to Device Reset..... | 95 |
| Table 9-36 | XML Parameters related to User Set Control..... | 96 |
| Table 9-37 | XML Parameters related to Sequencer Control..... | 98 |

Figures

| | | |
|------------|--|----|
| Figure 4-1 | Good Frame Grabber to Use Together: Coaxlink QSFP+ from Euresys..... | 20 |
| Figure 4-2 | Good Optical Fiber to Use: 12-fiber MPO (MPO female to MPO female) | 21 |
| Figure 4-3 | Good Transceiver to Use: 40G QSFP+ SR4 Transceiver..... | 21 |
| Figure 5-1 | Camera Block Diagram..... | 24 |
| Figure 5-2 | Spectral Response | 25 |
| Figure 5-3 | VC-21MDF-M/C460I Mechanical Dimension | 26 |
| Figure 5-4 | VC-21MDF-M/C460I-HS Mechanical Dimension | 26 |
| Figure 7-1 | VC-21MDF-M/C460I Back Panel..... | 34 |
| Figure 7-2 | CoF Connector..... | 35 |
| Figure 7-3 | Pin Assignments for 12-fiber MPO Connector | 36 |
| Figure 7-4 | Pin Assignments for Power Input and Control I/O Receptacle..... | 37 |
| Figure 7-5 | Trigger Input Schematic..... | 38 |
| Figure 7-6 | Strobe Output Schematic | 38 |
| Figure 8-1 | Exposure Start Triggering..... | 41 |
| Figure 8-2 | Frame Acquisition with Software Trigger Signal | 47 |
| Figure 8-3 | External Trigger Delay | 50 |
| Figure 8-4 | Timed Exposure Mode | 51 |
| Figure 8-5 | Trigger Overlapped with Timed Exposure Mode | 51 |
| Figure 8-6 | TriggerWidth Exposure Mode | 52 |
| Figure 8-7 | Overlapped Exposure and Readout | 53 |
| Figure 8-8 | Global Shutter | 55 |
| Figure 9-1 | Sequence of signal processing to correct images | 58 |
| Figure 9-2 | Region of Interest..... | 59 |
| Figure 9-3 | 2 × 2 Binning | 64 |

| | | |
|-------------|--|-----|
| Figure 9-4 | CoF and CXP Link Configuration | 65 |
| Figure 9-5 | VC-21MDF-M/C460I Pixel Format..... | 67 |
| Figure 9-6 | Operation of 1X_1Y (left) and 1X_2YE (right)..... | 68 |
| Figure 9-7 | Effective Data ROI..... | 70 |
| Figure 9-8 | Location of Defect Pixel to be corrected | 73 |
| Figure 9-9 | Generation and Application of Flat Field Data..... | 79 |
| Figure 9-10 | Bilinear Interpolated Magnification | 79 |
| Figure 9-11 | Flat Field Data Selector..... | 81 |
| Figure 9-12 | User Output | 85 |
| Figure 9-13 | Exposure Active Signal..... | 85 |
| Figure 9-14 | Debounce | 86 |
| Figure 9-15 | Timer Signal..... | 90 |
| Figure 9-16 | Grey Horizontal Ramp..... | 92 |
| Figure 9-17 | Grey Diagonal Ramp..... | 93 |
| Figure 9-18 | Grey Diagonal Ramp Moving..... | 93 |
| Figure 9-19 | Sensor Specific | 93 |
| Figure 9-20 | Original Image | 94 |
| Figure 9-21 | Reverse X Image..... | 94 |
| Figure 9-22 | User Set Control..... | 97 |
| Figure 9-23 | Sequencer Diagram (Use Case)..... | 101 |

Chapter 1. Precautions

General



- Do not drop, disassemble, repair, or alter the device. Doing so may damage the camera electronics and cause an electric shock.
- Do not let children or companion animals touch the device without supervision.
- Stop using the device and contact the nearest dealer or manufacturer for technical assistance if liquid such as water, drinks or chemicals gets into the device.
- Do not touch the device with wet hands. Doing so may cause an electric shock.
- Make sure that the temperature of the camera does not exceed the temperature range specified in 5.2 Specifications. Otherwise, the device may be damaged by extreme temperature.

Installation and Maintenance



- Do not install in dusty or dirty areas - or near an air conditioner or heater to reduce the risk of damage to the device.
- Avoid installing and operating in an extreme environment where vibration, heat, humidity, dust, strong magnetic fields, explosive/corrosive mists, or gases are present.
- Do not apply excessive vibration and shock to the device. This may damage the device.
- Avoid direct exposure to a high intensity light source. This may damage the image sensor.
- Do not install the device under unstable lighting conditions. Severe lighting change will affect the quality of the image produced by the device.
- Do not use solvents or thinners to clean the surface of the device. This can damage the surface finish.

Power Supply



- Applying incorrect power can damage the camera. If the voltage applied to the camera is greater or less than the camera's nominal voltage, the camera may be damaged or operate erratically. Please refer to 5.2 Specifications for the camera's nominal voltage.
 - ※ Vieworks Co., Ltd. does NOT provide power supplies with the devices.
- Make sure the power is turned off before connecting the power cord to the camera. Otherwise, damage to the camera may result.

Cleaning the Sensor Surface

Avoid cleaning the surface of the camera's sensor if possible. If you have dust or foreign matter on the sensor surface that will not blow off, use a soft lint free cotton bud dampened with a small quantity of high quality lens cleaner. Because electrostatic discharge (ESD) can damage the sensor, you must use a cloth (e.g. cotton) that will not generate static during cleaning.



Avoid dust or foreign matter on the sensor surface.

The camera is shipped with a protective plastic seal on the camera front. To prevent collecting dust or foreign matter on the camera sensor, make sure that you always put the protective seal in place when there is no lens mounted on the camera. In addition, make sure to always point the camera downward when there is no protective seal on the camera front or no lens mounted.

Procedures for Cleaning the Sensor

If you have dust or foreign matter on the sensor surface, follow the procedures below to wipe off.

1. Remove a contaminant by using an ionizing air gun.
If this step does not remove the contaminant, proceed to the next step.
2. Clean the contaminant on the sensor using one drop of lens cleaner on a non-fluffy cotton bud.
3. Wipe the cotton bud gently in only one direction (either left to right or right to left). Avoid wiping back and forth with the same cotton bud in order to ensure that the contaminants are removed and not simply transferred to a new location on the sensor surface.
4. Mount a lens, set the lens at a smaller aperture (e.g. F8), and then acquire images under bright lighting conditions. Check the images on the monitor for dark spots or stripes caused by the contaminant. Repeat the steps above until there is no contaminant present.



Caution!

If the sensor is damaged due to electrostatic discharge or the sensor surface is scratched during cleaning, the warranty is void.

Chapter 2. Warranty Coverage

The following cases are excluded from warranty coverage:

- The manufacturer is not responsible for equipment failure due to service or modification by unauthorized manufacturers, agents, or technicians.
- The manufacturer is not responsible for loss or damage to data due to operator negligence.
- If the user uses the product for purposes other than its intended use, or damage or malfunction occurs due to excessive use or negligence.
- When using incorrect power or not using under the usage conditions specified in the user manual.
- Natural disasters caused by lightning, earthquakes, fires, floods, etc.
- If a problem occurs due to replacement or modification of equipment parts and software without permission

If you have any product-related inquiries or require service, please contact the sales office or manufacturer. The warranty period is the period specified in the warranty when the product is sold, and applies from the time the product is shipped.

Chapter 3. Compliance & Certifications

3.1 FCC Compliance

This equipment has been tested and found to comply with the limits for a Class A digital device, pursuant to part 15 of the FCC Rules. These limits are designed to provide reasonable protection against harmful interference when the equipment is operated in a commercial environment. This equipment generates, uses, and can radiate radio frequency energy and, if not installed and used in accordance with the instruction manual, may cause harmful interference to radio communications. Operation of this equipment in a residential area is likely to cause harmful interference in which case the user will be required to correct the interference at his own expenses.

3.2 CE : DoC

EMC Directive 2014/30/EU
EN 55032:2012 (Class A), EN 55024:2010
Class A

3.3 KC

KCC Statement

| Type | Description |
|--|--|
| Class A (Broadcasting Communication Device for Office Use) | This device obtained EMC registration for office use (Class A), and may be used in places other than home. Sellers and/or users need to take note of this. |

Chapter 4. Package Components

4.1 Included Components

Package Components



VC-21MDF-M/C460I-HS

or

VC-21MDF-M/C460I

4.2 Additional Components

The cables, frame grabbers, and transceivers required to use the product are as follows, and this section provides the specifications to check when purchasing these components. These components are not provided by Vieworks as standard and should be purchased separately by the customer:

- Frame grabbers: 1 or 2 depending on number of channels to use.
- Fiber optic cables: 1 or 2 depending on number of channels to use.
- Transceivers: 2 or 4 depending on number of channels to use.

For the specifications of each component, see the corresponding section that follows.

4.2.1 Frame Grabbers

Currently, the frame grabber that provides the highest compatibility with this product is Coaxlink QSFP+ manufactured by Euresys. To use it as the single-channel mode, connect one frame grabber, and for the dual-channel mode, connect two frame grabbers to one single VC-21MDF-M/C460I camera. For the best performance and stability, it is recommended to purchase and use this frame grabber with the product.

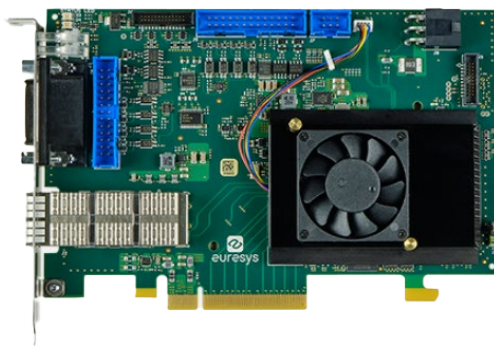

Figure 4-1 Good Frame Grabber to Use Together: Coaxlink QSFP+ from Euresys



Note:

The picture of the frame grabber above is provided by the manufacturer, Euresys, and it is recommended for the frame grabber to be updated the latest version of its driver.

4.2.2 Fiber-optic Cables

Currently, it needs to choose the 12-fiber MPO cable (MPO female to MPO female, Type B) which complies with the CXPR-007-2020 standard of the Japan Institute of International Affairs (JIJA) as the cable to use the product. Purchase one unit for single-channel use, or two units for dual-channel use.

- 12-fiber MPO connector (MPO female to MPO female), Type B, GI50/125 (OM3) optical fiber

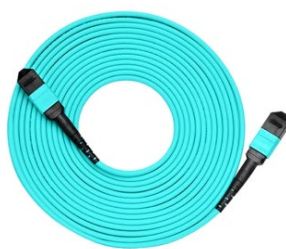

Figure 4-2 Good Optical Fiber to Use: 12-fiber MPO (MPO female to MPO female)

For detail information on the pin assignments and the pin configurations information, see 7.2.2.

4.2.3 Transceivers

As the gender for the cable, the frame grabber, and the product, use the 40G QSFP+ SR4 transceivers. Purchase two units for single-channel use, or four units for dual-channel use.

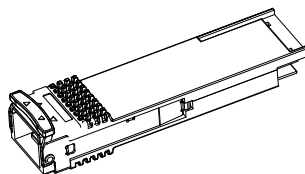

Figure 4-3 Good Transceiver to Use: 40G QSFP+ SR4 Transceiver

Chapter 5. Product Specifications

5.1 Overview

The VC-21MDF-M/C460I camera is Vieworks' first camera with the CoF(CoaXPress over Fiber) interface that offers 454 frames per second at 5120 × 4096 resolution. This new interface supports transmitting image data at up to 80 Gbps. Equipped with the Vieworks' innovative technologies, this camera delivers not only very fast frame rates but also big availability to extend lengths for cables. Featured with high speed and high performance, the VC-21MDF-M/C460I camera is an excellent choice for applications that require high speed and resolutions, such as FPD, PCB and semiconductor inspections.

For wide range of choice, Vieworks provides this amazing product in two different types, the fan type and the heat sink type, with the same specification.

Main Features

- High Speed 21 Megapixel CMOS Image Sensor
- CoaXPress over Fiber Interface up to 80 Gbps using 2 Links
- Output Channel: CoF × 1 / COF × 2
- Electronic Exposure Time Control (Global Shutter)
- Output Pixel Format: 8/10 bit
- Flat Field Correction
- Defective Pixel Correction
- Gain/Black Level Control
- Test Pattern
- Temperature Monitor
- Field Upgrade
- GenICam Compatible – XML based Control

5.2 Specifications

Technical specifications for the VC-21MDF-M/C460I are as follows.

| Specifications | VC-21MDF-M/C460I |
|---------------------------|--|
| Resolution (H×V) | 5120 × 4096 |
| Sensor | GSPRINT4521 |
| Sensor Size (Diagonal) | 23.04 mm × 18.43 mm (29.5 mm) |
| Sensor Type | High Speed CMOS Image Sensor |
| Pixel Size | 4.5 μm × 4.5 μm |
| Interface | CoaXPress over Fiber |
| Connection* | Euresys CoF Frame Grabber(pc3625) × 2 Optic Transceiver(40G QSFP+ SR4) × 4 Optic Cable(MPO female to MPO female, type B) × 2 |
| Max. Frame Rate (8 bit) | 454 fps |
| Exposure Time | 4 μs ~ 60 s (1 μs step) |
| Partial Scan (Max. Speed) | 18370 fps at 32 Lines |
| Pixel Data | Mono |
| Format (8 bit) | Color |
| Electronic Shutter | Global Shutter |
| Gain Control | Analog |
| | Digital |
| Black Level Control | 0 - 64 LSB at 10 bit |
| Exposure Mode | Free-Run, Timed, TriggerWidth |
| External Trigger | 3.3 ~ 24.0 V, 10 mA, Logical Level Input Optically Isolated |
| Software Trigger | Asynchronous, Programmable via Camera API |
| Digital I/O | TTL Level |
| Dynamic Range | Typical 62.14 dB at 10 bit |
| Cooling Method | Standard Cooling with a Fan |
| Mechanical (W×H×L) | 68 mm × 68 mm × 135 mm, 0.78 kg with F-mount (Fan) 68 mm × 68 mm × 135 mm, 0.77 kg with F-mount (Heat-sink) |
| Environmental | Operating: 0°C ~ 40°C, Storage: -40°C ~ 70°C |
| Lens Mount | F-mount, Custom mount available upon request |
| Power | External |
| | Dissipation |
| Compliance | CE, FCC, KC |

Table 5-1 Specifications VC-21MDF-M/C460I



To use the driver of the frame grabber:

It is recommended for the frame grabber to be updated the latest version of its driver.

Connection:

For more information on how to connect frame grabbers and a camera, see Chapter 6.

5.3 Camera Block Diagram

The block diagram of VC-21MDF-M/C460I is shown below.

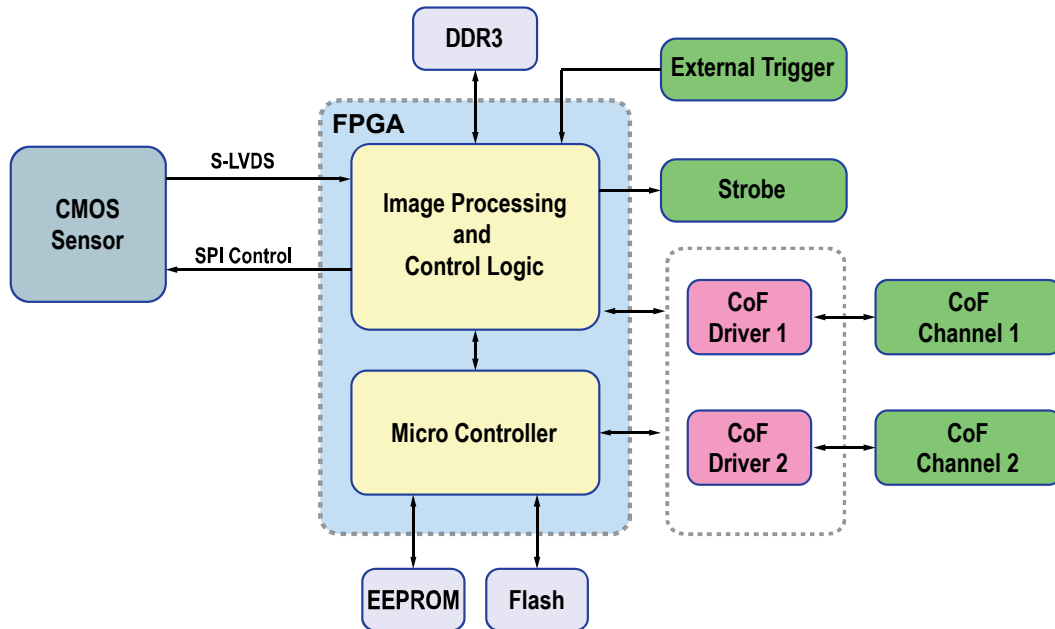

Figure 5-1 Camera Block Diagram

All controls and data processing of the camera are carried out in one FPGA chip. The FPGA generally consists of a 32-bit RISC Micro-Controller and Processing & Control logic. The Micro-Controller receives commands from the user through the CoF, CoaXPress-over-Fiber, interface and then processes them.

The Processing & Control logic processes the image data received from the CMOS image sensor and then transmits data through the CoF interface. The Processing & Control logic also controls time-sensitive trigger inputs and output signals. Furthermore, Flash and DDR3 are installed outside FPGA. The DDR3 is used to process images and the Flash stores the firmware to operate the Micro-Controller.



Single-channel, dual-channel:

This manual overall names CoF's two channels as single-channel (CoF Channel 1 on Figure 5-1) and dual-channel (CoF Channel 2 on Figure 5-1), respectively.

5.4 Spectral Response

The following graphs show the spectral response for the VC-21MDF-M/C460I.

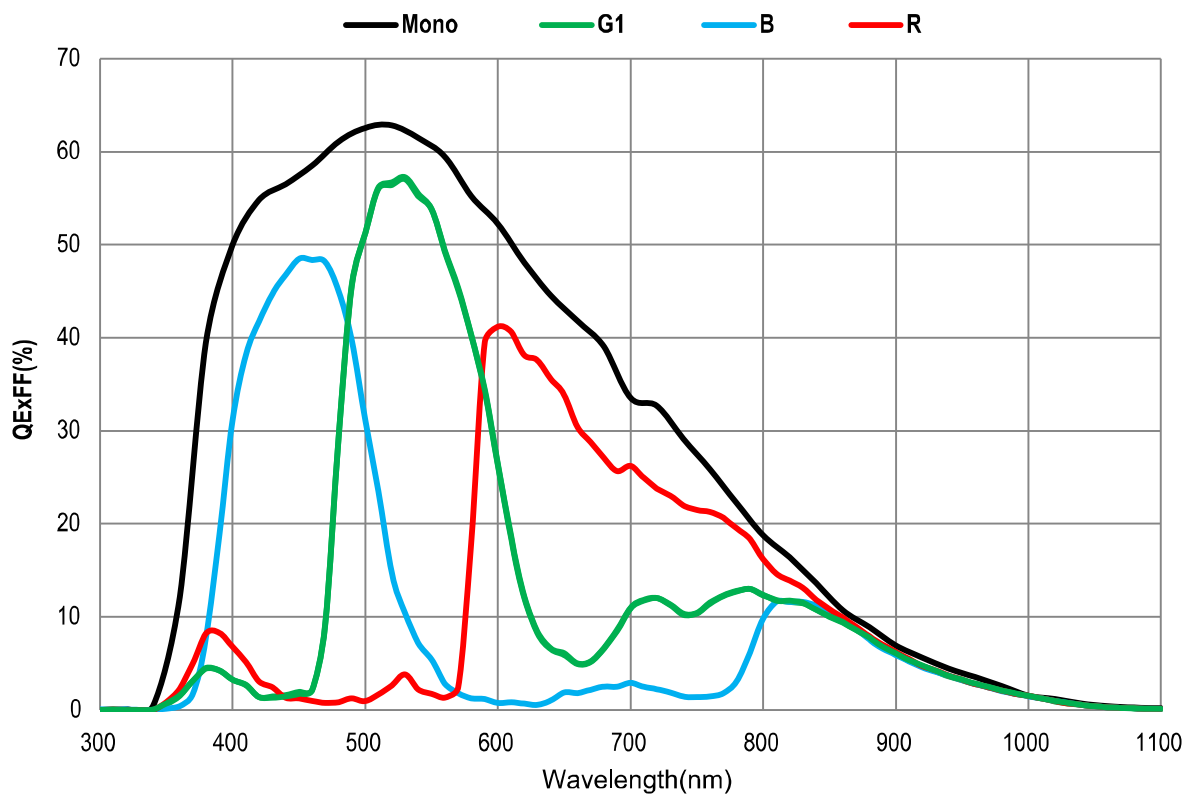

Figure 5-2 Spectral Response

5.5 Mechanical Specification

The camera dimensions in millimeters are shown in the following figure.

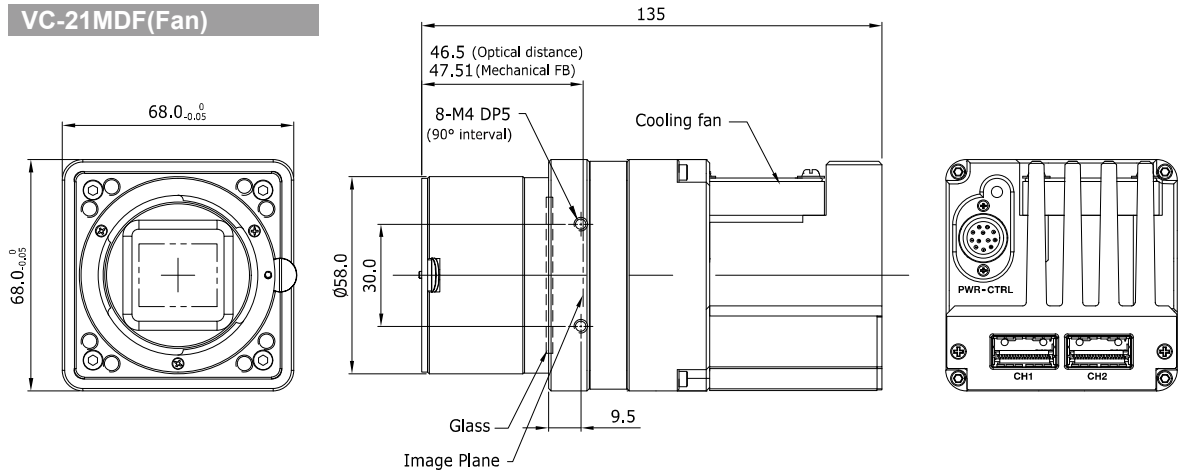

Figure 5-3 VC-21MDF-M/C460I Mechanical Dimension

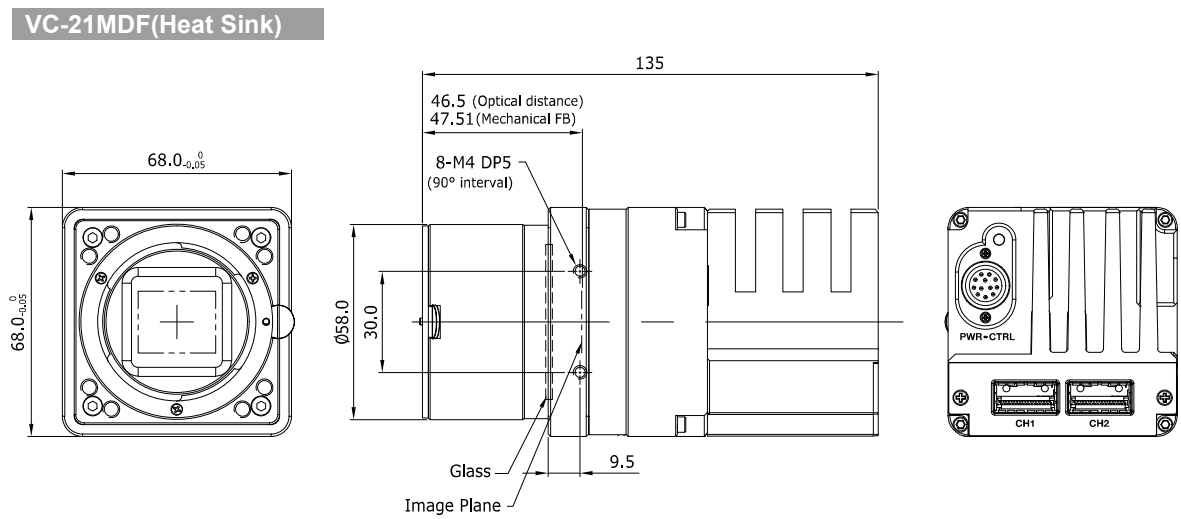

Figure 5-4 VC-21MDF-M/C460I-HS Mechanical Dimension

5.5.1 Camera Mounting and Heat Dissipation

Camera Mounting Recommendations for Antivibration

When you mount a camera in a poor condition, the fan equipped on the camera may amplify vibrations which can lead to blurry images. Follow the instructions below to prevent and/or reduce vibrations caused by the fan.

- Fix the camera's front or side surface by using at least four screws.
- Prevent ingress of foreign objects between the camera and system surfaces.
- Keep the camera's center of gravity as near as possible to the system's center of gravity.
- If your lens' weight or size is greater than the camera's, make and use proper mounting brackets to support the lens.
- Prevent foreign matters from falling into the fan. This may cause damage to the fan blades.

Camera Mounting Recommendations for Effective Heat Dissipation

- Do not obstruct the air inlets and outlets of the fan.
- If the fan is not available, leave enough space around the heat sink so that heat can be easily dissipated through the heat sink by natural convection.
- If the fan is not available, mount the camera on a metal structure made of high thermal conductive materials (e.g. Aluminum) to properly dissipate the heat generated by the camera.
- The contact surface of the camera must be at least 30% of the camera's Front-Block.

Chapter 6. Connecting the Camera

How to connect to the VC-21MDF-M/C460I camera is different from those of the other cameras with other interfaces (e.g. CoaXPress, Camera Link, GigE, etc.). Therefore, it is recommended to refer to this chapter for your safe installation.

This chapter provides how to install and configure the product initially in the following order:

1. Connecting the camera and other components
2. Setting up frame grabber's driver
3. Configuring channels
4. Changing ROI by channel



CoF single-channel, dual-channel:

For this product, the required components and way to configure vary depending on whether to use the mode of single-channel or dual-channel. Proceed the work in consideration of those.

6.1 Connecting the Camera and Other Components

First, check the camera and other components, after that, connect the camera to user's PC according to the following procedure:

1. Check if there are all the following components (for more details, see 4.2):
 - 1 of the VC-21MDF-M/C460I camera
 - 4 of QSFP+ SR4 transceivers for 40G (for single-channel, 2 units)
 - 2 of optic cables (MPO female to MPO female, type B), (for single-channel, 1 unit)
 - 2 of Euresys Coaxlink QSFP+ frame grabbers (for single-channel, 1 unit)
2. The minimum PC's specifications to use this product are as follows:
 - Need to support 2 of PCIe x8 Gen3 slots with a minimum of 8 GB RAM (possible to occur rejected frame when using an external graphic cards)
 - Available to use 2 of PCIe x8 Gen3 slots (for single-channel, 1 unit)

3. Assemble the CoF cable enables to connect between the frame grabber and the camera with the transceiver and the optic cable as follows. Plug all the ends of the optic cable into the transceivers respectively.

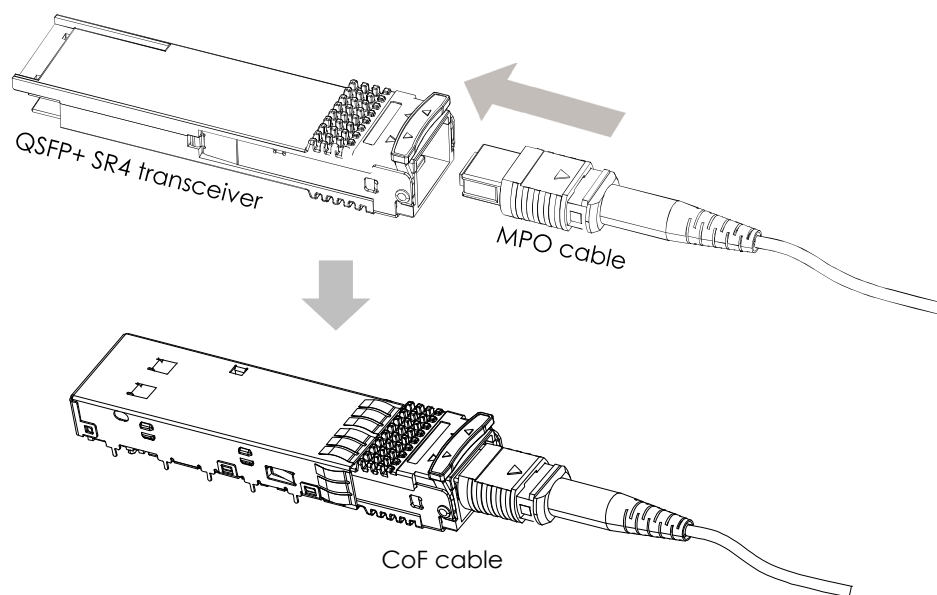

4. Plug one end of a CoF cable into the CH1 of the CoF connector on the camera and the other end of the CoF cable into the QSFP+ connector of the CoF frame grabber in your computer. And then, to use the dual-channel mode, plug another CoF cable into CH2 of the camera and the other CoF frame grabber also.

Once the task above has finished, see the next section to configure the driver for frame grabbers.

6.2 Setting Up the Driver for Frame Grabbers

After finishing connecting the camera and PC with a cable, set the driver in the following order:

1. Install the Euresys' eGrabbers software or VIS on a PC. It is recommended to download version 18.0 or later for eGrabbers or version 3.4.0 or later for VIS.
2. Once installation of the driver finishes, check if the "vc-21mdf.js" file exists in the folder where the driver is installed. If the file name is different such as "vc-21mf.js", change the file name to "vc-21mdf.js", and if the file does not exist, input the file firsthand into the folder. If you do not have this file, contact your seller.
3. Run the installed eGrabbers driver or VIS. For VIS users, it is recommended to activate the UseMultiBankCamera menu and then restart VIS.

If the installation went well, the program will correctly recognize the camera as one. If it appears as 2 of the cameras, check whether the file mentioned in step 2 above exists or not, otherwise, check whether the UseMultiBankCamera menu is activated or not.

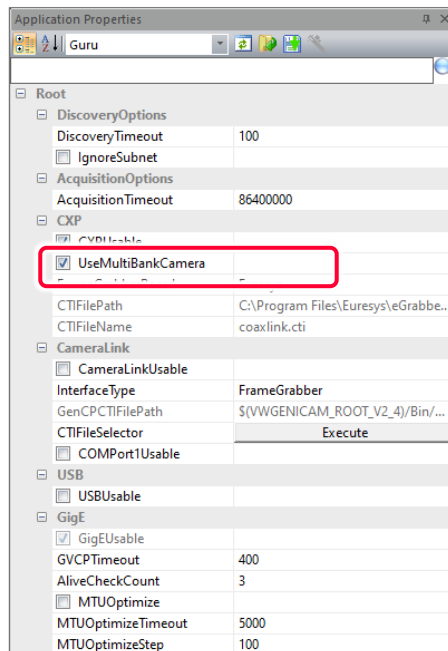

Once the task above has finished, see the next section to configure the channel to use.

6.3 Configuring Channels

This section provides how to configure the product by dividing per channel as follows:

1. Configuring single-channel mode
2. Configuring dual-channel mode

6.3.1 Configuring Single-channel Mode

To use of the single-channel mode, do the following:

1. Set the value of the LinkCount parameter to Count1.
2. Change LinkSharingHorizontalStripeCount to Count 0. Soon the LinksharingEnable value changes to False, automatically.
3. Move to the Data Stream or StreamProperties tab of the frame grabber, set StripeArrangement to Geometry_1X_2YE.
4. Save the settings in the user area and reboot the camera.
5. For 8-bit mode, set Linewidth on the tab equal to the Width value of the image to be output, otherwise, for 10-bit mode, set it to the double Width of the image to be output.

If single-channel configuration was successful, the Width and Height values become activated to be available to input, and the Height value of the image to be output is applied to the Height value.

6.3.2 Configuring Dual-channel Mode

To use of the dual-channel mode, do the following:

1. Set the value of the LinkCount parameter to Count2.
2. Change LinkSharingHorizontalStripeCount to Count 2. Soon the LinksharingEnable value changes to True, automatically.
3. Save the settings in the user area and reboot the camera. Then, the other relevant settings will change automatically. (StripeArrangement: Geometry_1X_1Y)

If dual-channel configuration was successful, the Width and Height values become inactivated to be disabled to input, and the half value of the image to be output is applied to the Height value.

6.4 Changing ROI by Channel

This section provides how to change ROI per channel as follows:

- Setting ROI in single-channel mode
- Setting ROI in dual-channel mode

6.4.1 Setting ROI in Single-channel Mode

To change Width and Height on the single-channel mode, do the following:

1. Stop if image acquisition is in progress.
2. Enter the required Width and Height values.
3. Enter the Linewidth value on the Stream tab for the frame grabber. For 8-bit, enter the Width value of the image to be output, and for 10-bit, enter the double value of the image width.
4. Save the current values in the UserSet and execute DeviceReset.

6.4.2 Setting ROI in Dual-channel Mode

On dual-channel mode, it is not available to change Width and Height directly, therefore, you should change them on single-channel mode and then switch to dual-channel mode. To do this, do the following:

1. Stop if image acquisition is in progress.
2. Set the value of the LinkCount parameter to Count1.
3. Change LinkSharingHorizontalStripeCount to Count 0. Soon the LinksharingEnable value changes to False, automatically.
4. Enter the required Width and Height values.
5. Enter the width value of the image to be output on the Linewidth value of the Stream tab for the frame grabber.
6. Set the value of the LinkCount parameter to Count2.
7. Change LinkSharingHorizontalStripeCount to Count2. Soon the LinksharingEnable value changes to True, automatically.

6.5 Installing Vieworks Imaging Solution

You can download the Vieworks Imaging Solution at <http://vision.vieworks.com>. You should perform the software installation first and then the hardware installation.

Chapter 7. Camera Interface

7.1 General Description

As shown in the following figure, three types of connectors and an LED indicator are located on the back of the camera and have the functions as follows:

- ① Status LED: displays power status and operation mode.
- ② 12-pin Power Input and Control Receptacle: supplies power to the camera, and can be set to operate as an input and output line.
- ③ CoF Connectors: transmit video data and controls the camera.

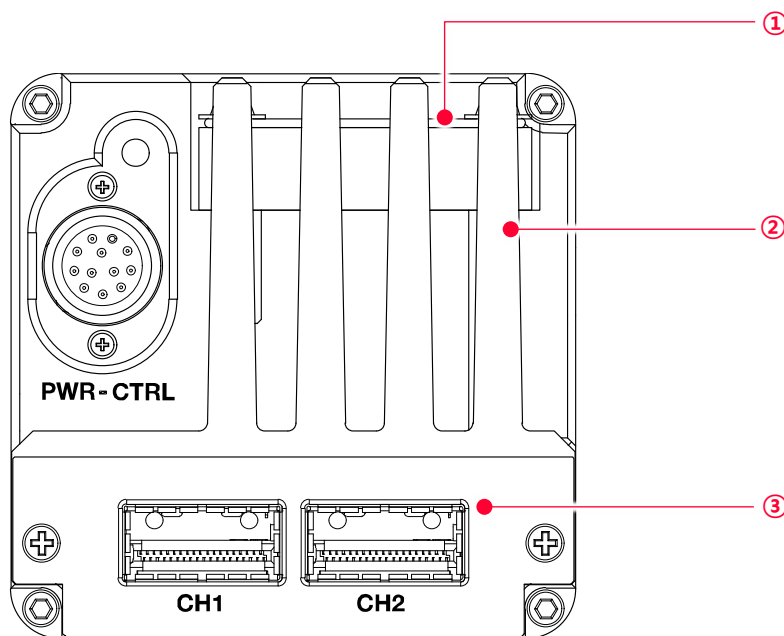

Figure 7-1 VC-21MDF-M/C460I Back Panel



Note:

Information on the back panel of VC-21MDF-M/C460I-HS is the same as above.

7.2 CoaXPress-over-Fiber Connector

CoaXPress-over-Fiber protocol includes an automatic link detection mechanism (Plug and Play) to correctly detect the camera to the CoF Frame Grabber connection. The connection between the camera and CoF Frame Grabber uses an optic cable and provides up to 40 Gbps bit rate per cable.

7.2.1 CoF Connector

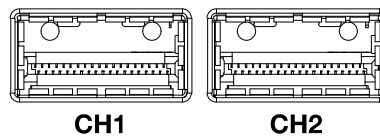

Figure 7-2 CoF Connector

The CoF connectors on the VC-21MDF-M/C460I camera comply with the CoaXPress 2.0 standard and the following table shows the channel assignments.

| Channel | Max. Bit Rate per Coax | Type |
|---------|------------------------|----------------------|
| CH1 | 40 Gbps | Master Connection |
| CH2 | 40 Gbps | Extension Connection |

Table 7-1 Channel Assignments for CoF Connector



Note:

When you connect a camera to a CoF Frame Grabber using optic cables, make sure to connect the cables to their correct Frame Grabbers. If you connect the CH1, CH2 of the CoF connector on the camera to an incorrect CoF Frame Grabbers per each, the camera may not transmit images properly or the communication between the computer and camera may fail. For more information, refer to Chapter 6.

7.2.2 MPO Cable's Connector

The connector configuration of the 12-fiber MPO cable used with the product is as follows:

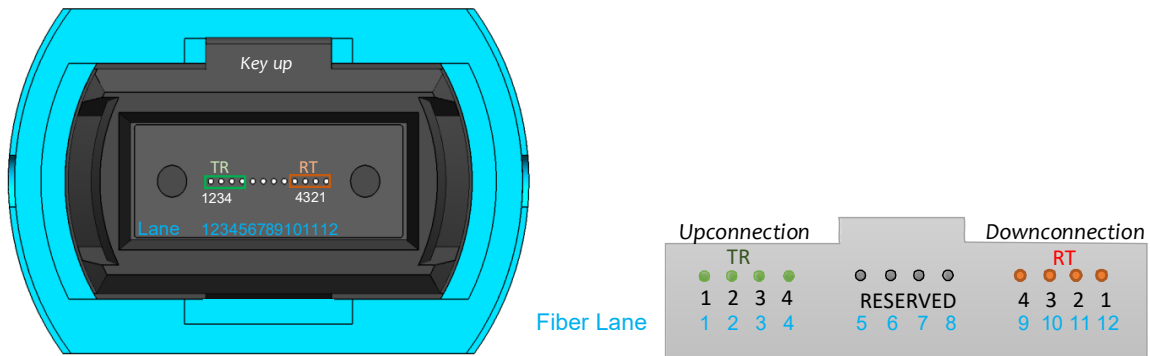

Figure 7-3 Pin Assignments for 12-fiber MPO Connector

| Fiber Lane | Name Plug Connector (Device side) | Name Locking Receptacle (Host side) | CXP Physical Medium Topology |
|------------|-----------------------------------|-------------------------------------|------------------------------|
| 1 | TR1(TX1) | TR1 (TX1) | Master Upconnection0 |
| 2 | TR2(TX2) | TR2 (TX2) | (Extension Upconnection1 |
| 3 | TR3(TX3) | TR3 (TX3) | (Extension Upconnection2 |
| 4 | TR4(TX4) | TR4 (TX4) | Extension Upconnection3 |
| 5 - 8 | Reserved | Reserved | Reserved |
| 9 | RT4(RX4) | RT4(RX4) | Master Downconnection0 |
| 10 | RT3(RX3) | RT3(RX3) | Extension Downconnection1 |
| 11 | RT2(RX2) | RT2(RX2) | Extension Downconnection2 |
| 12 | RT1(RX1) | RT1 (RX1) | Extension Downconnection3 |

Table 7-2 Pin Configurations for 12-fiber MPO Connector



Note:

The information provided in this section is based on the J1A CXPR-007-2020 standard. For more information, refer to J1A's Optical Interface Guideline for CoaXPress document.

7.3 Power Input and Control I/O Receptacle

The power input receptacle is a Hirose 12-pin connector (part # HR10A-10R-12PB). The pin assignments and configurations are as follows:

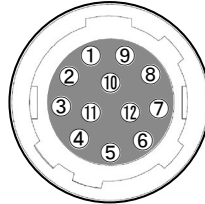

Figure 7-4 Pin Assignments for Power Input and Control I/O Receptacle

| Pin Number | Signal | Type | Description |
|------------|--|--------|----------------------|
| 1,12 | DC Ground | Ground | Camera Power Ground |
| 2,11 | +12 VDC | Power | Camera Power +12 VDC |
| 3 | Output - | Ground | Output Common Ground |
| 5 | Trigger IN- | Input | - |
| 6 | Trigger IN+ | Input | - |
| 4,7,8,9,10 | Output1+ Output2+ Output3+ Output4+ Output5+ | Output | 3.3 V TTL Output |

Table 7-3 Pin Configurations for Power Input and Control I/O Receptacle



Note:

- A recommended mating connector for the Hirose 12-pin connector is the Hirose 12-pin plug (part # HR10A-10P-12S) or the equivalent.
- It is recommended that you use the power adapter, which has at least 3 A current output at 12 - 24 VDC voltage output (You need to purchase a power adapter separately.).
- When using the camera at full power, the allowable current (2A) of pin 1 may be exceeded, so it is recommended to apply power to both connection pins (2 in total) when applying 12V power.

Precaution for Power Input



Caution!

- Make sure the power is turned off before connecting the power cord to the camera. Otherwise, damage to the camera may result.
- If the voltage applied to the camera is greater than specified in the specifications, damage to the camera may result.

7.4 Trigger Input Circuit

The following figure shows trigger signal input circuit of the 12-pin connector. Transmitted trigger signal is applied to the internal circuit through a photo coupler. With the Debounce feature, you can specify the width of input signal to be considered as a valid input signal. An external trigger circuit example is shown below.

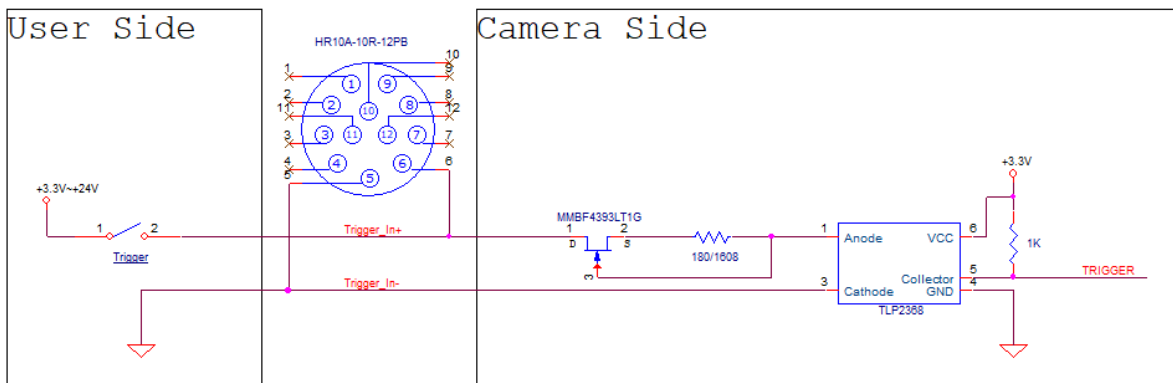

Figure 7-5 Trigger Input Schematic

7.5 Strobe Output Circuit

The following figure shows the output circuit of the 12-pin connector. You can configure the output line by setting the Digital I/O Control (refer to 9.16 Digital I/O Control).

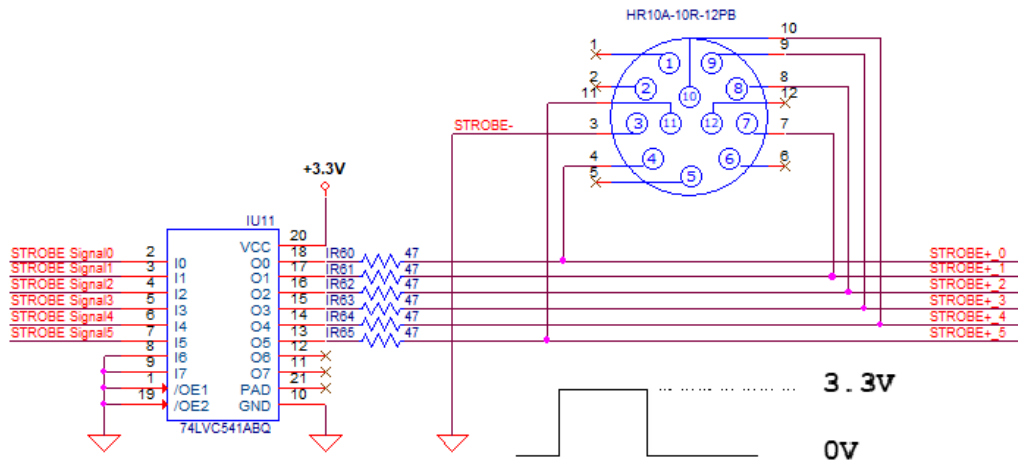

Figure 7-6 Strobe Output Schematic

Chapter 8. Acquisition Control

This chapter provides detailed information about controlling image acquisition.

- Triggering image acquisition
- Setting the exposure time
- Controlling the camera's image acquisition rate
- Variation of the camera's maximum allowed image acquisition rate according to the camera settings

8.1 Overview

This section presents an overview of the elements involved with controlling the acquisition of images.

The followings are involved in controlling the acquisition of images.

- Acquisition Start and Acquisition Stop commands and the Acquisition Mode parameter
- Exposure start trigger
- Exposure time control
- Frame acquisition process on the camera
- Global shutter
- Maximum Allowed Frame Rate



Note:

When reading the explanations in the overview and in this entire chapter, keep in mind that the term frame is typically used to mean a single acquired image.

8.2 Acquisition Start/Stop Commands and Acquisition Mode

This section describes function available to use via the followings:

- Acquisition Start/Stop commands
- Acquisition Mode

The details about each item above is described in the order from the following section.

8.2.1 Acquisition Start/Stop Commands

The Acquisition Start command prepares the camera to acquire images. The camera cannot acquire images unless an Acquisition Start command has first been executed.

Executing an Acquisition Stop command terminates the camera's ability to acquire images.

8.2.2 Acquisition Mode

The Acquisition Mode parameter affects directly how the Acquisition Start command works.

There are three of types available to select in this parameter as follows:

- **Continuous:**
Acquires frames continuously once the Acquisition Start command is called until the Acquisition Stop command is called.
- **SingleFrame:**
Acquires one single frame after the Acquisition Start command is called, and then, finishes acquiring images with calling the Acquisition Stop command automatically.
- **MultiFrame:**
Acquires frames as many as the numbers designated on the AcquisitionFrameCount parameter after the Acquisition Start command is called, and then, finishes acquiring images with calling the Acquisition Stop command automatically.



Note:

The Acquisition Start command will remain in effect until you execute an Acquisition Stop command. Once an Acquisition Stop command has been executed, the camera will not be able to acquire frames until a new Acquisition Start command is executed. If a user calls an Acquisition Stop command on the way of image acquisition, the work will finish after finishing the ongoing acquisition all.

8.2.3 Exposure Start Trigger

Applying an exposure start trigger signal to the camera will exit the camera from the waiting for exposure start trigger acquisition status and will begin the process of exposing and reading out a frame (see Figure 8-1). As soon as the camera is ready to accept another exposure start trigger signal, it will return to the waiting for exposure start trigger acquisition status. A new exposure start trigger signal can then be applied to the camera to begin another frame exposure. The exposure start trigger has two modes: off and on.

If the Trigger Mode parameter is set to Off, the camera will generate all required exposure start trigger signals internally, and you do not need to apply exposure start trigger signals to the camera. The rate at which the camera will generate the signals and acquire frames will be determined by the way that you set several frame rate related parameters.

If the Trigger Mode parameter is set to On, you must trigger exposure start by applying exposure start trigger signals to the camera. Each time a trigger signal is applied, the camera will begin a frame exposure. When exposure start is being triggered in this manner, it is important that you do not attempt to trigger frames at a rate that is greater than the maximum allowed (There is a detailed explanation about the maximum allowed frame rate at the end of this chapter.). Exposure starts trigger signals applied to the camera when it is not in a waiting for exposure start trigger acquisition status will be ignored.

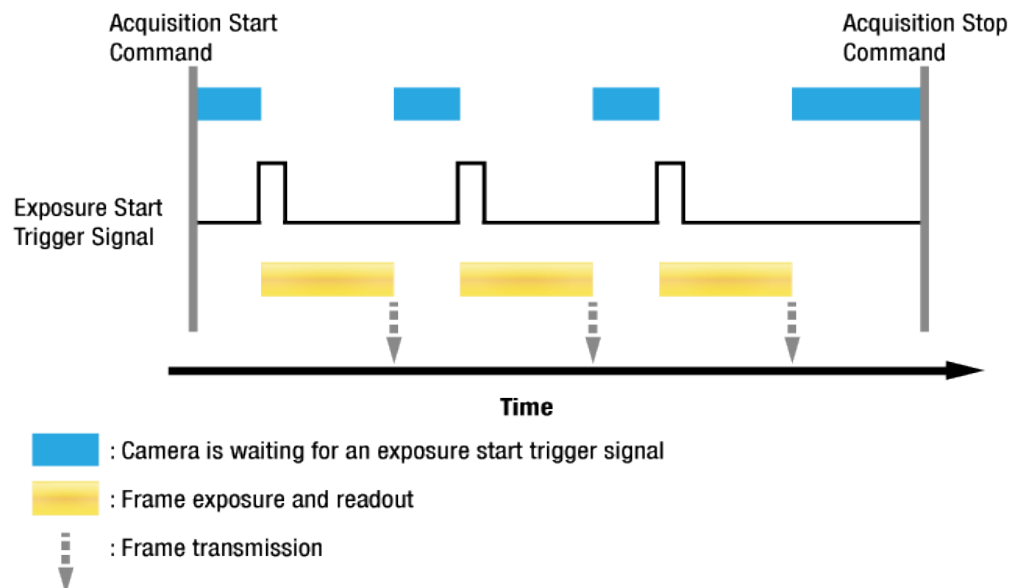

Figure 8-1 Exposure Start Triggering

8.2.4 Applying Trigger Signals

The paragraphs above mention “applying a trigger signal”. There are five ways to apply an exposure start trigger signal to the camera: via Software, via UserOutput0, via LinkTrigger0, via Timer0 Active or via Line0 (commonly referred to a hardware).

- To apply trigger signals via Software, you must set the Trigger Source parameter to Software. At that point, each time a Trigger Software command is executed, the exposure start trigger signal will be applied to the camera.
- To apply trigger signals via UserOutput0, you must set the Trigger Source parameter to UserOutput0. At that point, you can apply an exposure start trigger signal to the camera by switching the User Output Value parameter between On (rise) and Off (fall).
- To apply trigger signals via CH1 of the CoF Frame Grabber, you must set the Trigger Source parameter to LinkTrigger0. At that point, each time a proper CoaXPress trigger signal is applied to the camera by using the APIs provided by a CoF Frame Grabber manufacturer, the exposure start trigger signal will be applied to the camera. For more information, refer to your CoF Frame Grabber User Manual.
- To apply trigger signals via the user-defined Timer feature, you must set the Trigger Source parameter to Timer0 Active. When you set the Timer Trigger Source parameter to Line0 in the Counter And Timer Control category, you can apply an exposure start trigger signal to the camera by using a Timer that uses the Line0 signal as the source signal.
- To apply trigger signals via hardware (external), you must set the Trigger Source parameter to Line0. At that point, each time a proper electrical signal is applied to the camera, an occurrence of the exposure start trigger signal will be recognized by the camera.

8.2.5 Exposure Time Control

When an exposure start trigger signal is applied to the camera, the camera will begin to acquire a frame.

A critical aspect of frame acquisition is how long the pixels in the camera's sensor will be exposed to light during the frame acquisition.

If the Trigger Source parameter is set to Software, the Exposure Time parameter will determine the exposure time for each frame.

If the Trigger Source parameter is set to UserOutput0, LinkTrigger0, Timer0 Active or Line0, there are two modes of operation: Timed and TriggerWidth.

With the Timed mode, the Exposure Time parameter will determine the exposure time for each frame.

With the TriggerWidth mode, the way that you manipulate the rise and fall of the User Output, CoaXPress, Timer or hardware (external) signal will determine the exposure time. The TriggerWidth mode is especially useful if you want to change the exposure time from frame to frame.

8.3 Exposure Start Trigger

The Trigger Selector parameter is used to select a type of trigger and only the Exposure Start trigger is available on the VC-21MDF-M/C460I camera. The Exposure Start trigger is used to begin frame acquisition. Exposure start trigger signals can be generated within the camera or may be applied externally by setting the Trigger Source parameter to Software, UserOutput0, LinkTrigger0, Timer0 Active or Line0. If an exposure start trigger signal is applied to the camera, the camera will begin to expose a frame.

8.3.1 Trigger Mode

The main parameter associated with the exposure start trigger is the Trigger Mode parameter. The Trigger Mode parameter for the exposure start trigger has two available settings: Off and On.

Trigger Mode = Off

When the Trigger Mode parameter is set to Off, the camera will generate all required exposure start trigger signals internally, and you do not need to apply exposure start trigger signals to the camera.

If the Trigger Mode parameter is set to Off, the camera will automatically begin generating exposure start trigger signals when it receives an Acquisition Start command. The camera will continue to generate exposure start trigger signals until it receives an Acquisition Stop command.



Free-Run

When you set the Trigger Mode parameter to Off, the camera will generate all required trigger signals internally. When the camera is set this way, it will constantly acquire images without any need for triggering by the user. This use case commonly referred as "free run".

The rate at which the exposure start trigger signals are generated may be determined by the camera's Acquisition Frame Rate parameter.

- If the parameter is set to a value less than the maximum allowed frame rate with the current camera settings, the camera will generate exposure start trigger signals at the rate specified by the parameter setting.
- If the parameter is set to a value greater than the maximum allowed frame rate with the current camera settings, the camera will generate exposure start trigger signals at the maximum allowed frame rate.

Exposure Time Control with Trigger Mode = Off

When the Trigger Mode parameter is set to Off, the exposure time for each frame acquisition is determined by the value of the camera's Exposure Time parameter.

Trigger Mode = On

When the Trigger Mode parameter is set to On, you must apply an exposure start trigger signal to the camera each time you want to begin a frame acquisition. The Trigger Source parameter specifies the source signal that will act as the exposure start trigger signal.

The available settings for the Trigger Source parameter are:

- Software
- UserOutput0
- LinkTrigger0: For more information, refer to your CoF Frame Grabber User Manual.
- Timer0Active: For more information, refer to 9.19 Timer Control.
- Line0: Refer to 7.4 Trigger Input Circuit for more information.

You must also set the Trigger Activation parameter after setting the Trigger Source parameter.

The available settings for the Trigger Activation parameter are:

- Falling Edge: Specifies that a falling edge of the electrical signal will act as the exposure start trigger.
- Rising Edge: Specifies that a rising edge of the electrical signal will act as the exposure start trigger.

Exposure Time Control with Trigger Mode = On

When the Trigger Mode parameter is set to On and the Trigger Source parameter is set to Software, the exposure time for each frame acquisition is determined by the value of the camera's Exposure Time parameter.

When the Trigger Mode parameter is set to On and the Trigger Source parameter is set to LinkTrigger0 or Line0, the exposure time for each frame acquisition will be determined by the Exposure Mode parameter settings as follows:

- Exposure Mode = Timed: Exposure time can be controlled with the Exposure Time parameter.
- Exposure Mode = TriggerWidth: Exposure time can be controlled by manipulating the external trigger signal.

When the Trigger Mode parameter is set to On and the Trigger Source parameter is set to Timer0 Active, the exposure time for each frame acquisition will be determined by the Exposure Mode parameter settings as follows:

- Exposure Mode = Timed: Exposure time can be controlled with the Exposure Time parameter.
- Exposure Mode = TriggerWidth: When you set the Timer Trigger Activation parameter to Rising/Falling Edge, the exposure time is controlled with the Timer Duration parameter. When you set the Timer Trigger Activation parameter to Level High/Low, the exposure time can be controlled by manipulating the external trigger signal.

When the Trigger Mode parameter is set to On and the Trigger Source parameter is set to UserOutput0, the exposure time for each frame acquisition will be determined by the Exposure Mode parameter settings as follows:

- Exposure Mode = Timed: Exposure time can be controlled with the Exposure Time parameter.
- Exposure Mode = TriggerWidth: Exposure time can be controlled by switching the User Output Value parameter between On and Off.

8.3.2 Using a Software Trigger Signal

If the Trigger Mode parameter is set to On and the Trigger Source parameter is set to Software, you must apply a software trigger signal (exposure start) to the camera to begin each frame acquisition. Assuming that the camera is in a waiting for exposure start trigger acquisition status, frame exposure will start when the software trigger signal is received by the camera. Figure 8-2 illustrates frame acquisition with a software trigger signal.

When the camera receives a software trigger signal and begins exposure, it will exit the waiting for exposure start trigger acquisition status because at that point, it cannot react to a new exposure start trigger signal. As soon as the camera is capable of reacting to a new exposure start trigger signal, it will automatically return to the waiting for exposure start trigger acquisition status.

The exposure time for each acquired frame will be determined by the value of the camera's Exposure Time parameter.

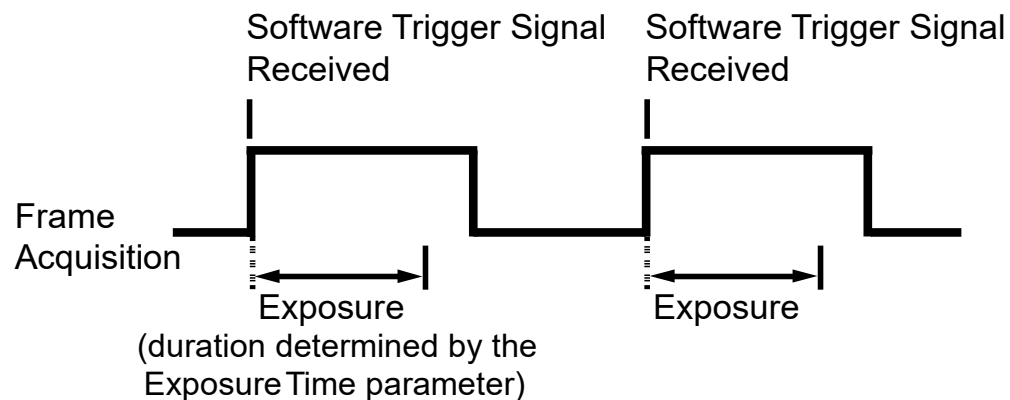

Figure 8-2 Frame Acquisition with Software Trigger Signal

When you are using a software trigger signal to start each frame acquisition, the frame rate will be determined by how often you apply a software trigger signal to the camera, and you should not attempt to trigger frame acquisition at a rate that exceeds the maximum allowed for the current camera settings (There is a detailed explanation about the maximum allowed frame rate at the end of this chapter.). Software trigger signals that are applied to the camera when it is not ready to receive them will be ignored.

8.3.3 Using a CoaXPress Trigger Signal

If the Trigger Mode parameter is set to On and the Trigger Source parameter is set to LinkTrigger0, you must apply a CoaXPress trigger signal to the camera to begin each frame acquisition. A CoaXPress trigger signal will act as the exposure start trigger signal for the camera. For more information, refer to your CoF Frame Grabber User Manual.

A rising edge or a falling edge of the CoaXPress signal can be used to trigger frame acquisition. The Trigger Activation parameter is used to select rising edge or falling edge triggering.

Assuming that the camera is in a waiting for exposure start trigger acquisition status, frame acquisition will start whenever the appropriate edge transition is received by the camera.

When the camera receives a CoaXPress trigger signal and begins exposure, it will exit the waiting for exposure start trigger acquisition status because at that point, it cannot react to a new exposure start trigger signal.

As soon as the camera is capable of reacting to a new exposure start trigger signal, it will automatically return to the waiting for exposure start trigger acquisition status.

When the camera is operating under control of a CoaXPress signal, the period of the CoaXPress trigger signal will determine the rate at which the camera is acquiring frames:

$$\frac{1}{\text{CoaXPress signal period in seconds}} = \text{Frame Rate}$$

For example, if you are operating a camera with a CoaXPress trigger signal period of 50 ms(0.05 s):
So, in this case, the frame rate is 20 fps.

8.3.4 Using an External Trigger Signal

If the Trigger Mode parameter is set to On and the Trigger Source parameter is set to Line0, an externally generated electrical signal injected into the Control I/O receptacle will act as the exposure start trigger signal for the camera. This type of trigger signal is generally referred to as a hardware trigger signal.

A rising edge or a falling edge of the external signal can be used to trigger frame acquisition. The Trigger Activation parameter is used to select rising edge or falling edge triggering.

Assuming that the camera is in a waiting for exposure start trigger acquisition status, frame acquisition will start whenever the appropriate edge transition is received by the camera.

When the camera receives an external trigger signal and begins exposure, it will exit the waiting for exposure start trigger acquisition status because at that point, it cannot react to a new exposure start trigger signal.

As soon as the camera is capable of reacting to a new exposure start trigger signal, it will automatically return to the waiting for exposure start trigger acquisition status.

When the camera is operating under control of an external signal, the period of the external trigger signal will determine the rate at which the camera is acquiring frames:

$$\frac{1}{\text{External signal period in seconds}} = \text{Frame Rate}$$

For example, if you are operating a camera with an External trigger signal period of 50 ms (0.05 s):

So, in this case, the frame rate is 20 fps.

External Trigger Delay

When you set the Trigger Source parameter to Timer0Active, you can specify a delay between the receipt of a hardware trigger signal and when the trigger becomes effective.

1. Set the Timer Trigger Source parameter in the Counter And Timer Control category to Line0.
2. Set the Timer Delay parameter to the desired Timer delay in microseconds.
3. Set the Trigger Source parameter in the Acquisition Control category to Timer0Active.
4. Execute the Acquisition Start command and inject an externally generated electrical signal into the Control I/O receptacle. Then, the delay set by the Timer Delay parameter expires and the exposure for image acquisition begins.

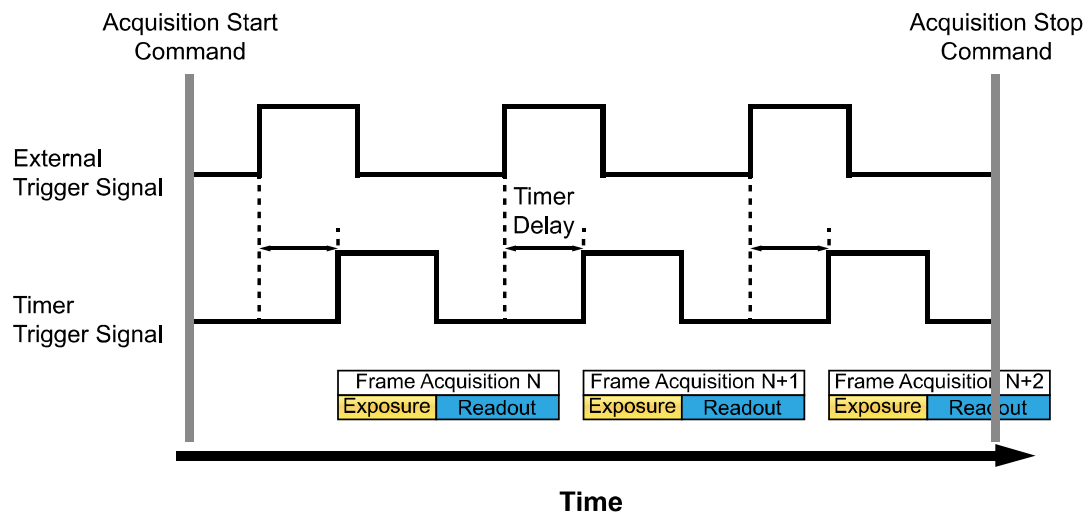

Figure 8-3 External Trigger Delay

8.3.5 Exposure Mode

If you are triggering the start of frame acquisition with an externally (CoaXPress or External) generated trigger signal, two exposure modes are available: Timed and TriggerWidth.

Timed Exposure Mode

When the Timed mode is selected, the exposure time for each frame acquisition is determined by the value of the camera's Exposure Time parameter. If the camera is set for rising edge triggering, the exposure time starts when the external trigger signal rises. If the camera is set for falling edge triggering, the exposure time starts when the external trigger signal falls. The following figure illustrates Timed exposure with the camera set for rising edge triggering.

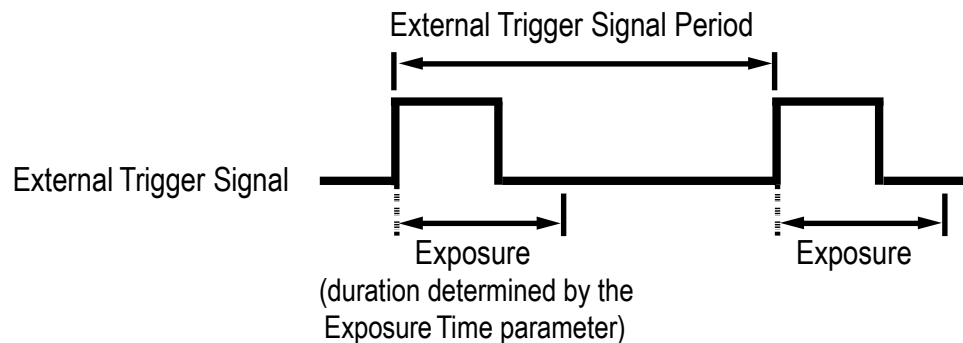

Figure 8-4 Timed Exposure Mode

Note that if you attempt to trigger a new exposure start while the previous exposure is still in progress, the trigger signal will be ignored.

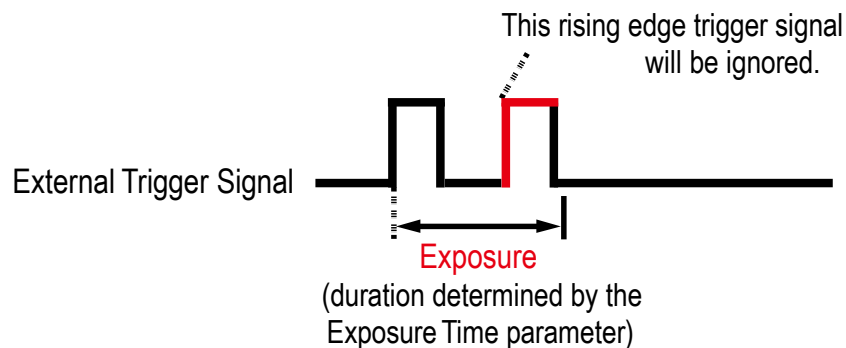

Figure 8-5 Trigger Overlapped with Timed Exposure Mode

TriggerWidth Exposure Mode

When the TriggerWidth exposure mode is selected, the length of the exposure for each frame acquisition will be directly controlled by the external trigger signal (CoaXPress or External). If the camera is set for rising edge triggering, the exposure time begins when the external trigger signal rises and continues until the external trigger signal falls. If the camera is set for falling edge triggering, the exposure time begins when the external trigger signal falls and continues until the external trigger signal rises. The following figure illustrates TriggerWidth exposure with the camera set for rising edge triggering.

TriggerWidth exposure is especially useful if you intend to vary the length of the exposure time for each frame.

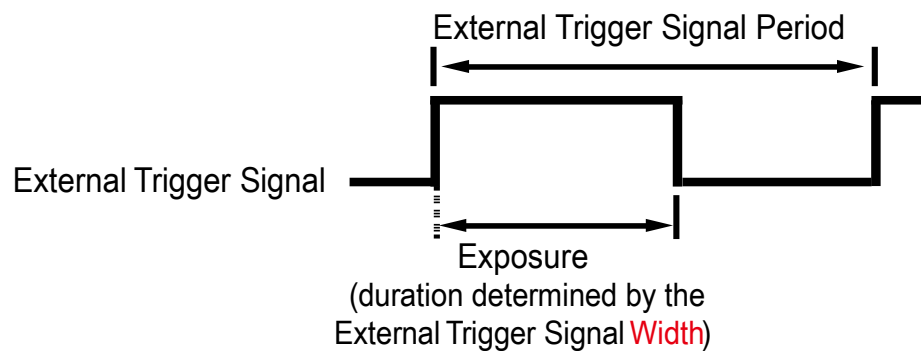

Figure 8-6 TriggerWidth Exposure Mode

8.4 Overlapping Exposure with Sensor Readout

The frame acquisition process on the camera includes two distinct parts. The first part is the exposure of the pixels in the image sensor. Once exposure is complete, the second part of the process – readout of the pixel values from the sensor – takes place. In regard to this frame acquisition process, the VC-21MDF-M/C460I camera basically operates with ‘overlapped’ exposure so that the exposure for a new frame can be overlapped with the sensor readout for the previous frame.

When a new trigger signal is applied to the camera while reading out the previous frame, the camera begins the process of exposing a new frame. This situation is illustrated in the following figure with the Trigger Mode set to On, the Trigger Source set to Line0 and the Exposure Mode set to TriggerWidth.

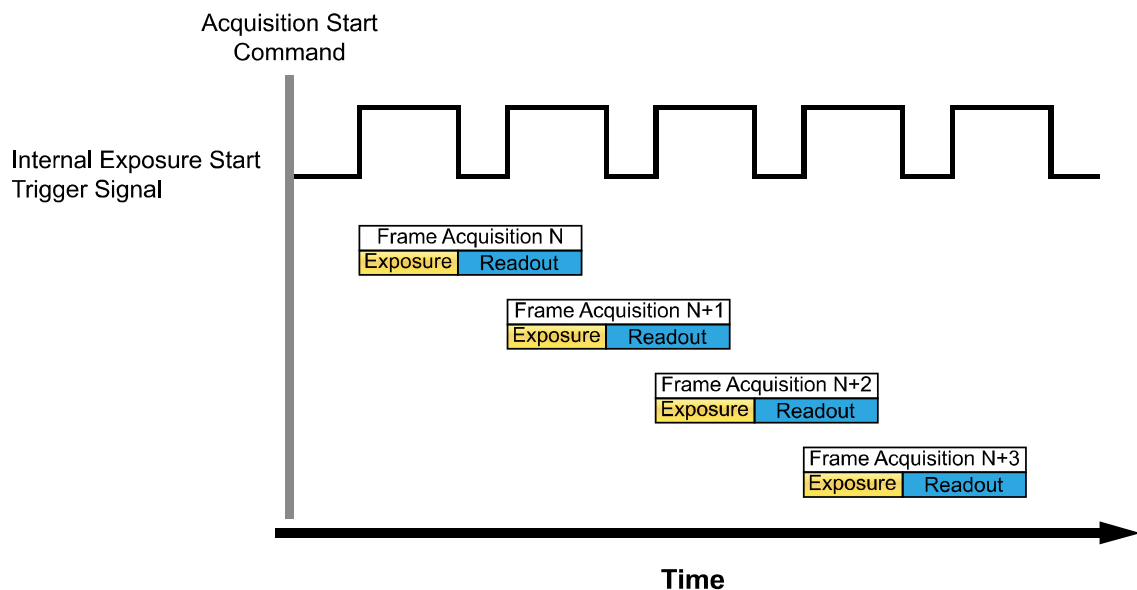

Figure 8-7 Overlapped Exposure and Readout

Determining whether your camera is operating with overlapped exposure and readout is not a matter of issuing a command or changing a setting. Rather a way that you operate the camera will determine whether the exposures and readouts are overlapped or not. If we define the “Frame Period” as the time from the start of exposure for one frame acquisition to the start of exposure for the next frame acquisition, then:

- Overlapped: Frame Period \leq Exposure Time + Readout Time

Guidelines for Overlapped Exposure

Since the VC-21MDF-M/C460I camera operates with overlapped exposure, you must keep in mind two important guidelines:

- You must not begin the exposure for a new frame while the exposure for the previous frame is in progress.
- You must not end the exposure for the current frame until the readout for the previous frame is complete.

When you are operating the camera with overlapped exposure and using an external trigger signal to trigger image acquisition, you could use the camera's Exposure Time parameter settings and timing formula to calculate when it is safe to begin each new acquisition.

8.5 Global Shutter

The VC-21MDF-M/C460I camera is equipped with an image sensor that has an electronic global shutter. When an exposure start trigger signal is applied to the camera equipped with a global shutter, exposure begins for all lines in the sensor as shown in the figure below. Exposure continues for all lines in the sensor until the programmed exposure time ends or when the exposure start trigger signal ends the exposure time if the camera is using the TriggerWidth exposure mode. At the end of the exposure time, exposure ends for all lines in the sensor. Immediately after the end of exposure, pixel data readout begins and proceeds line by line until all pixel data is read out of the sensor. A main characteristic of a global shutter is that for each frame acquisition, all of the pixels in the sensor start exposing at the same time and all end exposing at the same time. This means that image brightness tends to be more uniform over the entire area of each acquired image, and it helps to minimize problems with acquiring images of object in motion.

The camera can provide an Exposure Active output signal that will go high when the exposure time for a frame acquisition begins and will go low when the exposure time ends.

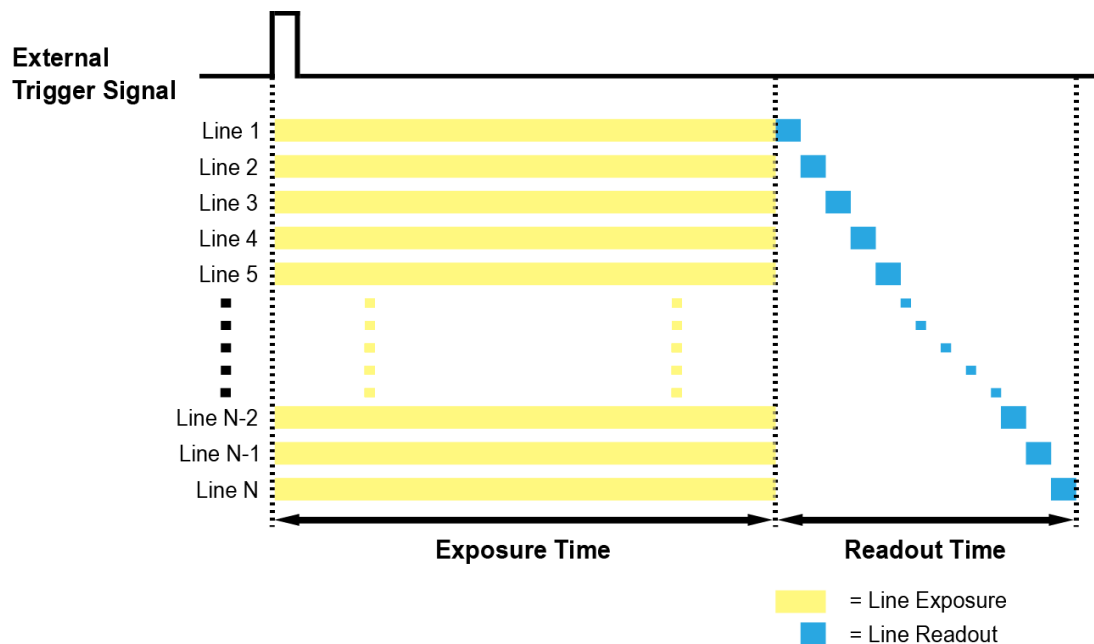

Figure 8-8 Global Shutter

8.6 Maximum Allowed Frame Rate

In general, the maximum allowed acquisition frame rate on the camera may be limited by several factors:

- The amount of time that it takes to transmit an acquired frame from the camera to your computer. The amount of time needed to transmit a frame depends on the bandwidth assigned to the camera.
- The amount of time it takes to read an acquired frame out of the image sensor and into the camera's frame buffer. This time varies depending on the setting for ROI. Frames with a smaller height and/or width take less time to read out of the sensor. The frame height and width are determined by the camera's Height and Width settings in the Image Format Control category.
- The CXP Link Configuration. When the camera is set for a CXP Link Configuration that uses more channels, it can typically transfer data out of the camera faster than when it is set for a CXP Link Configuration that uses less channels.
- The exposure time for acquired frames. If you use very long exposure time, you can acquire fewer frames per second.

8.6.1 Increasing the Maximum Allowed Frame Rate

You may find that you would like to acquire frames at a rate higher than the maximum allowed with the camera's current settings. In this case, you must adjust one or more of the factors that can influence the maximum allowed frame rate and then check to see if the maximum allowed frame rate has increased.

- The time that it takes to transmit a frame out of the camera is the main limiting factor on the frame rate. You can decrease the frame transmission time (and thus increase the maximum allowed frame rate) by using the ROI feature. Decreasing the size of the Image ROI may increase the maximum allowed frame rate. If possible, decrease the height and/or width of the Image ROI.
- If you are using a CXP Link Configuration with a low number of channels, consider using a CXP Link Configuration with a high number of channels. This will usually increase the maximum allowed frame rate.
- If you are using normal exposure times and you are using the camera at its maximum resolution, your exposure time will not normally restrict the frame rate. However, if you are using long exposure time, it is possible that your exposure time is limiting the maximum allowed frame rate. If you are using a long exposure time, try using a shorter exposure time and see if the maximum allowed frame rate increases (You may need to compensate for a lower exposure time by using a brighter light source or increasing the opening of your lens aperture.).

**Note:**

A very long exposure time severely limits the camera's maximum allowed frame rate. As an example, assume that your camera is set to use a 1 second exposure time. In this case, because each frame acquisition will take at least 1 second to be completed, the camera will only be able to acquire a maximum of one frame per second.

Chapter 9. Camera Features

9.1 Sequence of Signal Processing

To acquire the best-quality images, the VC-21MDF-M/C460I camera handles signals in the following sequence:

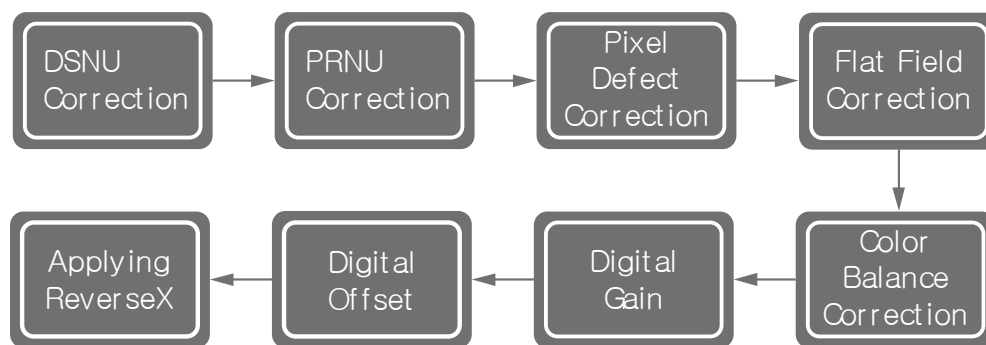

Figure 9-1 Sequence of signal processing to correct images

After finishing the current job, doing all the prior jobs to the current work again is recommended. It may affect the other jobs that have been done before the current job.

9.2 Region of Interest

The Image Region of Interest (ROI) feature allows you to specify a portion of the sensor array. You can acquire only the frame data from the specified portion of the sensor array while preserving the same quality as you acquire a frame from the entire sensor array.

With the ROI feature, you can increase the maximum allowed frame rate by decreasing the Width and/or Height parameters.

The VC-21MDF-M/C460I camera automatically centers the ROI along the sensor's Y axis. You can change the size of ROI by setting the Width and Height parameters.

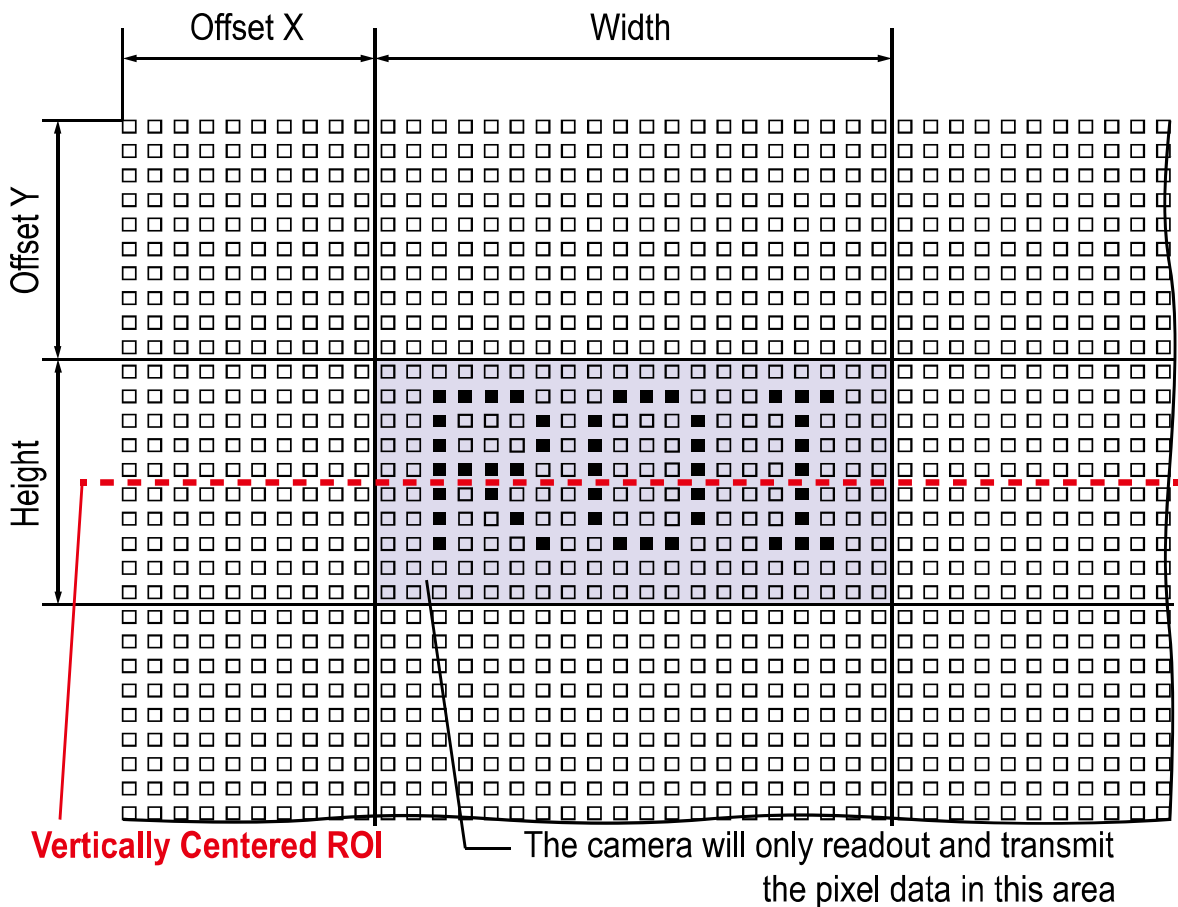

Figure 9-2 Region of Interest

The XML parameters related to ROI settings are as follows.

| XML Parameters | | Value | Description |
|--------------------|---------------------------|-------|--|
| ImageFormatControl | SensorWidth ^a | - | Effective width of the sensor |
| | SensorHeight ^a | - | Effective height of the sensor |
| | WidthMax | - | Maximum allowed width of the image with the current camera settings |
| | HeightMax | - | Maximum allowed height of the image with the current camera settings |
| | Width ^b | - | Sets the Width of the Image ROI. |
| | Height ^b | - | Sets the Height of the Image ROI. |
| | OffsetX ^c | - | Sets the horizontal offset from the origin to the Image ROI. |
| | OffsetY ^a | - | Shows the vertical offset from the origin to the Image ROI. |

The unit for all parameters in this table is pixel.

a: Read only. User cannot change the value.

b: User configurable parameters for setting ROI

c: User configurable parameters for setting the origin of the ROI

Table 9-1 XML Parameters related to ROI

You can change the size of ROI by setting the Width and Height parameters in the Image Format Control category. You can also change the position of the ROI origin by setting the Offset X and Offset Y parameters.

In the case of this product, it aligns the center of Image ROI with the sensor's center automatically, due to the feature of the sensor. Therefore, there is no need to set the Width value and the Height value to the ROI size as needed, because the OffsetX and OffsetY values will automatically vary so that the ROI is centered on the image even if you set nothing.

- On the VC-21MDF-M/C460I camera, both the Width and the Height parameters must be set to a multiple of 32.

The minimum allowed setting values for the ROI Width and Height are shown below.

| Camera Model | Minimum Width Settings | Minimum Height Settings |
|------------------|------------------------|-------------------------|
| VC-21MDF-M/C460I | 640 | 32 |

Table 9-2 Minimum ROI Width and Height Settings

When changing number of the CoF channel, the LineWidth value of the frame grabber needs to be also changed to match the width of the image to be acquired. The XML parameters to set on the Stream Properties (VIS) or Data Stream (eGrabber) tab to do this are as follows:

| XML Parameters | | Value | Description |
|----------------|-----------|-------|--|
| StreamControl | LineWidth | - | Indicates Width value recognized by a frame grabber, inputs the same value as the width value of the image to be acquired (When using 10 bits in single channel, enter this value as double of the image width) |

Table 9-3 XML Parameters related to LineWidth



How to change ROI:

For the product, how to change ROI varies depending on whether it uses on the single-channel or dual-channel mode. To change the Width and Height values, it needs to exchange to the single-channel available to enter the ROI values as needed. See 6.4 for this method.

On the VC-21MDF-M/C460I camera, the maximum allowed frame rates depending on Horizontal and Vertical ROI changes are shown below. The maximum allowed frame rates shown below are based on 8 bit Pixel Format, the frame rates get about 20% faster usually when the Pixel Format changes from 10 bit to 8 bit. However, the frame rate doesn't get faster if it already reaches the maximum frame rate of the sensor output.

| ROI Size (H × V) | CoF Single-channel | CoF Daul-Channel |
|------------------|--------------------|------------------|
| 640 × 32 | 17991.4 fps | 18370.0 fps |
| 5120 × 32 | 2766.8 fps | 5360.6 fps |
| 5120 × 1024 | 222.1 fps | 443.2 fps |
| 5120 × 2016 | 115.7 fps | 231.1 fps |
| 5120 × 3008 | 78.2 fps | 156.3 fps |
| 640 × 4096 | 454.9 fps | 462.8 fps |
| 1024 × 4096 | 285.7 fps | 462.8 fps |
| 2016 × 4096 | 146.2 fps | 292.0 fps |
| 3008 × 4096 | 98.1 fps | 196.0 fps |
| 4000 × 4096 | 73.9 fps | 147.4 fps |
| 5120 × 4096 | 57.7 fps | 115.4 fps |

Table 9-4 Maximum Frame Rates by VC-21MDF-M/C460I ROI Changes_CXP-12×1

| ROI Size (H × V) | CoF Single-channel | CoF Daul-Channel |
|------------------|--------------------|------------------|
|------------------|--------------------|------------------|

| | | |
|-------------|-------------|-------------|
| 640 × 32 | 18370.0 fps | 18370.0 fps |
| 5120 × 32 | 5371.6 fps | 10128.9 fps |
| 5120 × 1024 | 443.2 fps | 880.4 fps |
| 5120 × 2016 | 231.1 fps | 293.7 fps |
| 5120 × 3008 | 156.3 fps | 293.7 fps |
| 640 × 4096 | 462.8 fps | 462.8 fps |
| 1024 × 4096 | 462.8 fps | 462.8 fps |
| 2016 × 4096 | 292.0 fps | 462.8 fps |
| 3008 × 4096 | 196.0 fps | 391.1 fps |
| 4000 × 4096 | 147.4 fps | 293.7 fps |
| 5120 × 4096 | 115.4 fps | 230.0 fps |

Table 9-5 Maximum Frame Rates by VC-21MDF-M/C460I ROI Changes_CXP-12×2

| ROI Size (H × V) | CoF Single-channel | CoF Dual-Channel |
|------------------|--------------------|------------------|
| 640 × 32 | 18370.0 fps | 18370.0 fps |
| 5120 × 32 | 10128.9 fps | 18242.1 fps |
| 5120 × 1024 | 880.4 fps | 1744.0 fps |
| 5120 × 2016 | 293.7 fps | 293.7 fps |
| 5120 × 3008 | 293.7 fps | 293.7 fps |
| 640 × 4096 | 462.8 fps | 462.8 fps |
| 1024 × 4096 | 462.8 fps | 462.8 fps |
| 2016 × 4096 | 462.8 fps | 462.8 fps |
| 3008 × 4096 | 391.1 fps | 462.8 fps |
| 4000 × 4096 | 293.7 fps | 462.8 fps |
| 5120 × 4096 | 230.0 fps | 454.9 fps |

Table 9-6 Maximum Frame Rates by VC-21MDF-M/C460I ROI Changes_CXP-12×4

**Caution!**

Your CXP-12 Frame Grabber may place additional restrictions on how the ROI location and size must be set. Refer to your CoF Frame Grabber user manual for more information.

9.3 Binning

The Binning has the effects of increasing the level value and decreasing resolution by summing the values of the adjacent pixels and sending them as one pixel.

The XML parameters related to Binning are as follows.

| XML Parameters | | Value | Description |
|---------------------|------------------------|---------|---|
| ImageFormat Control | BinningSelector | Sensor | Applies the Binning in analog by the sensor. (Mono only) |
| | | Logic | Applies the Binning in digital by the logic. |
| | Binning HorizontalMode | Sum | Adds pixel values from the adjacent pixels as specified in the Binning Horizontal, and then sends them as one pixel. |
| | | Average | Adds pixel values from the adjacent pixels as specified in the Binning Horizontal and divides them by the number of combined pixels, and then sends them as one pixel. (Logic binning only) |
| | BinningHorizontal | 1×, 2× | The number of horizontal pixels to combine together. |
| | Binning VerticalMode | Sum | Adds pixel values from the adjacent pixels as specified in the Binning Vertical, and then sends them as one pixel. |
| | | Average | Adds pixel values from the adjacent pixels as specified in the Binning Vertical and divides them by the number of combined pixels, and then sends them as one pixel. (Logic binning only) |
| | BinningVertical | 1×, 2× | The number of vertical pixels to combine together. |

Table 9-7 XML Parameters related to Binning

For example, if you set 2×2 binning, the camera's resolution is reduced to $1/4$. If you set the Binning Mode to Sum, the maximum allowed resolution of the image is reduced $1/2$ and the responsivity of the camera is quadrupled. If you set the Binning Mode to Average, the maximum allowed resolution of the image is reduced to $1/2$, but there is no difference in responsivity between a binned image and an original image. The Width Max and Height Max parameter, indicating the maximum allowed resolution of the image with the current camera settings, will be updated depending on the binning settings. And also, the Width, Height, Offset X and Offset Y parameters will be updated depending on the binning settings. You can verify the current resolution through the Width and Height parameters.

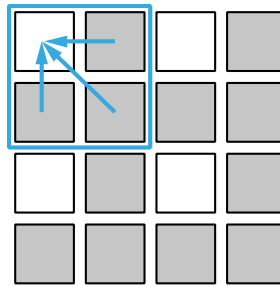

2 × 2 Binning

Figure 9-3 2 × 2 Binning



Note:

In the color mode, binning is performed by summing values of the same-color pixels among the adjacent pixels, and after that, sending them as one pixel.

9.4 CoF Link Sharing Control

The VC-21MDF-M/C460I camera must be connected to a CXP-12 Frame Grabber of CoF interface. CoF interface allows you to connect a camera to a Frame Grabber supporting CoF by using simple optic cabling and allows up to 20 Gbps data rate per a cable. The VC-21MDF-M/C460I camera supports one master connection and up to one extension connections to configure a link. And it supports up to four channels of CXP-12 by connecting just one single CoF channel. In compliance with the CoaXPress-over-Fiber standard, the camera includes an automatic link detection mechanism (Plug and Play) to correctly detect the camera to CoF Frame Grabber connections.

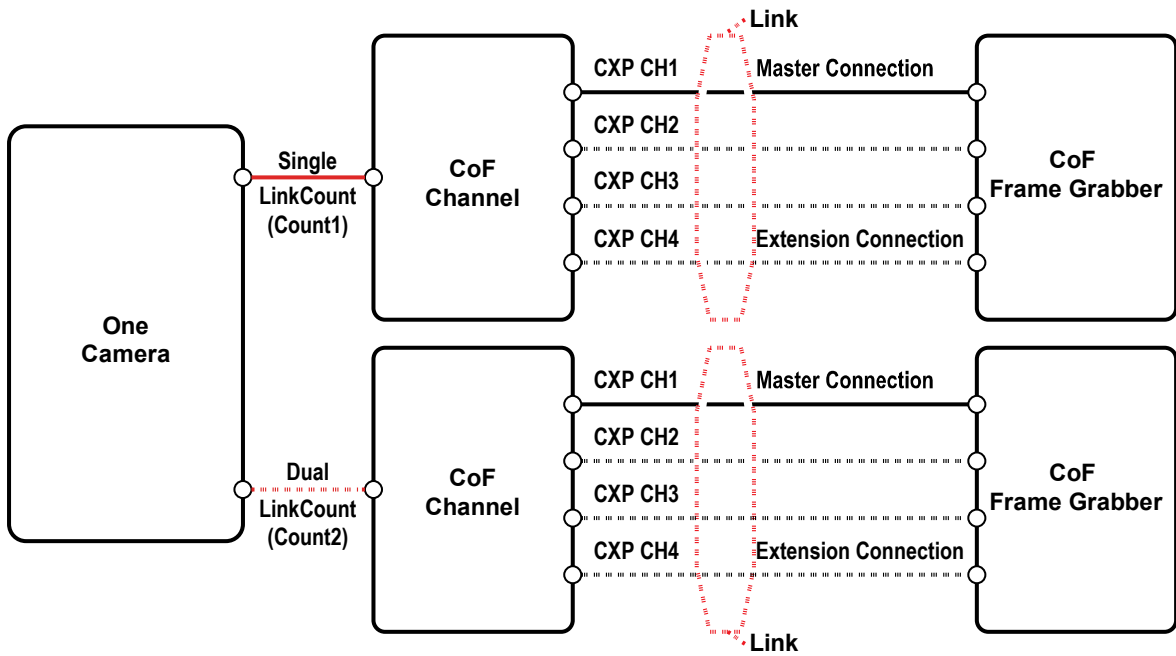

Figure 9-4 CoF and CXP Link Configuration

The XML parameters related to the link configuration between the camera and CoF Frame Grabber are as follows.

| XML Parameters | Value | Description |
|-----------------------------------|-----------|---|
| LinkSharingControl | - | Sets connection related to CoF |
| LinkCount | Count1 | Sets as CoF single-channel mode |
| | Count2 | Sets as CoF dual-channel mode |
| LinkSharingEnable | Read Only | Shows single-channel, dual-channel as False, True, respectively |
| LinkSharingHorizontal StripeCount | Count0 | Sets as CoF single-channel mode |
| | Count2 | Sets as CoF dual-channel mode |
| CxpLinkConfiguration Preferred | Read Only | Displays bit rate and the number of connections to be set for the link configuration between the camera and Host (Frame Grabber) while discovering devices. Saves the current CxpLinkConfiguration values as the CxpLinkConfigurationPreferred value when you execute the User Set Save parameter. |
| CxpLinkConfiguration | CXP6_X1 | Sets bit rate and the number of connections for the link configuration. e.g. CXP12_X4: Four connections running at a maximum of CXP12 speed (12.5 Gbps) |
| | CXP6_X2 | |
| | CXP6_X4 | |
| | CXP10_X1 | |
| | CXP10_X2 | |
| | CXP10_X4 | |
| | CXP12_X1 | |
| | CXP12_X2 | |
| CXP12_X4 | | |

Table 9-8 XML Parameters related to CoF Link Configuration

9.5 Pixel Format

The VC-21MDF-M/C460I camera processes image data in the unit of 10 bit. The pixel format of the image data is available to be chosen among 8 bit or 10 bit with the Pixel Format parameter. For instance, the 2 least significant bits will be dropped from overall 10 bits when the camera is set for 10-bit pixel format.

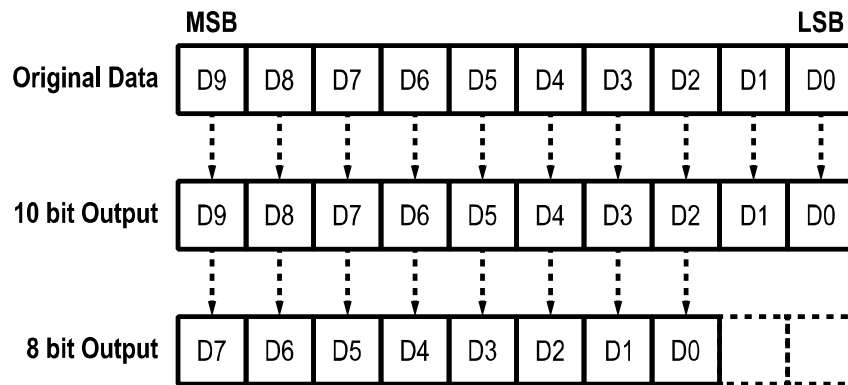

Figure 9-5 VC-21MDF-M/C460I Pixel Format

The XML parameter related to Pixel Format is as follows.

| XML Parameter | Description |
|--------------------------------|--|
| ImageFormatControl PixelFormat | Sets the pixel format supported by the device. |

Table 9-9 XML Parameter related to Pixel Format

The available pixel formats on the monochrome and color cameras are as follows.

| Mono Sensor | Color Sensor |
|-------------|--------------|
| Mono 8 | Mono 8 |
| Mono 10 | Mono 10 |
| | Bayer GB 8 |
| | Bayer GB 10 |

Table 9-10 Pixel Format Values

9.6 Device Tap Geometry

The VP-288MX2-M15K camera supports two of the Device Tap Geometry type.

- Geometry_1X_1Y
- Geometry_1X_2YE

Consider the following properties related to the feature and choose the method that works best:

- W: Width, H: Height
- X Start: X-coordinate of the first pixel column
- Y Start: Y-coordinate of the first pixel row
- X End: X-coordinate of the last pixel column
- Y End: Y-coordinate of the last pixel row
- X Step: Difference of X-coordinates between consecutive pixel columns;
X-step is positive when X-coordinates are increasing along a row; it is negative otherwise.
- Y Step: Difference of Y-coordinates between consecutive pixel rows;
Y-step is positive when Y-coordinates is increasing at the end of a line; it is negative otherwise.

| Geometry Name | X Start | X End | Step X | Y Start | Y End | Step Y |
|---------------|---------|-------|--------|---------|-------|--------|
| 1X_1Y | 1 | W | 1 | 1 | H | 1 |
| 1X_2YE | Tap 1 | 1 | W | 1 | H/2 | 1 |
| | Tap 2 | 1 | W | H | H/2+1 | -1 |

Table 9-11 Tap Geometry Properties

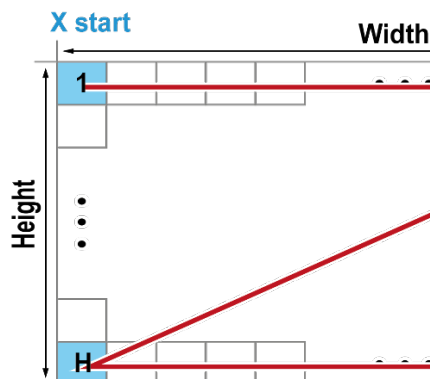

Figure 9-6 Operation of 1X_1Y (left) and 1X_2YE (right)

The setting for this Device Tap Geometry should use the Geometry XML parameters supported by the frame grabber, not by the camera. Use the following parameters on the Stream Properties tab in VIS or on the Data Stream tab in eGrabber:

| XML Parameters | | Value | Description |
|----------------|--------------------|-----------------|--|
| Stream Control | Stripe Arrangement | Geometry_1X_1Y | Used on single-channel and Proceeds in the direction of top-down |
| | | Geometry_1X_2YE | Used on dual-channel and Proceeds in the direction of top-down and bottom-up, respectively. 2 of taps indicates 2 of frame grabbers. |

Table 9-12 XML Parameters related to Geometry

9.7 Data ROI (Color Only)

The Balance White Auto feature provided by the color camera uses the pixel data from a Data Region of Interest (ROI) to adjust the related parameters.

The XML parameters related to Data ROI are as follows.

| XML Parameters | Value | Description |
|----------------|-----------------|-------------|
| DataRoiControl | DataRoiSelector | Balance |
| | | WhiteAuto |
| | DataRoiOffsetX | - |
| | DataRoiOffsetY | - |
| | DataRoiWidth | 32 - 5120 |
| | DataRoiHeight | 2 - 4096 |

Table 9-13 XML Parameters related to Data ROI

Only the pixel data from the area of overlap between the Data ROI and the Image ROI by your settings will be effective if you use the Image ROI and Data ROI at the same time. The effective ROI is determined as shown in the figure below.

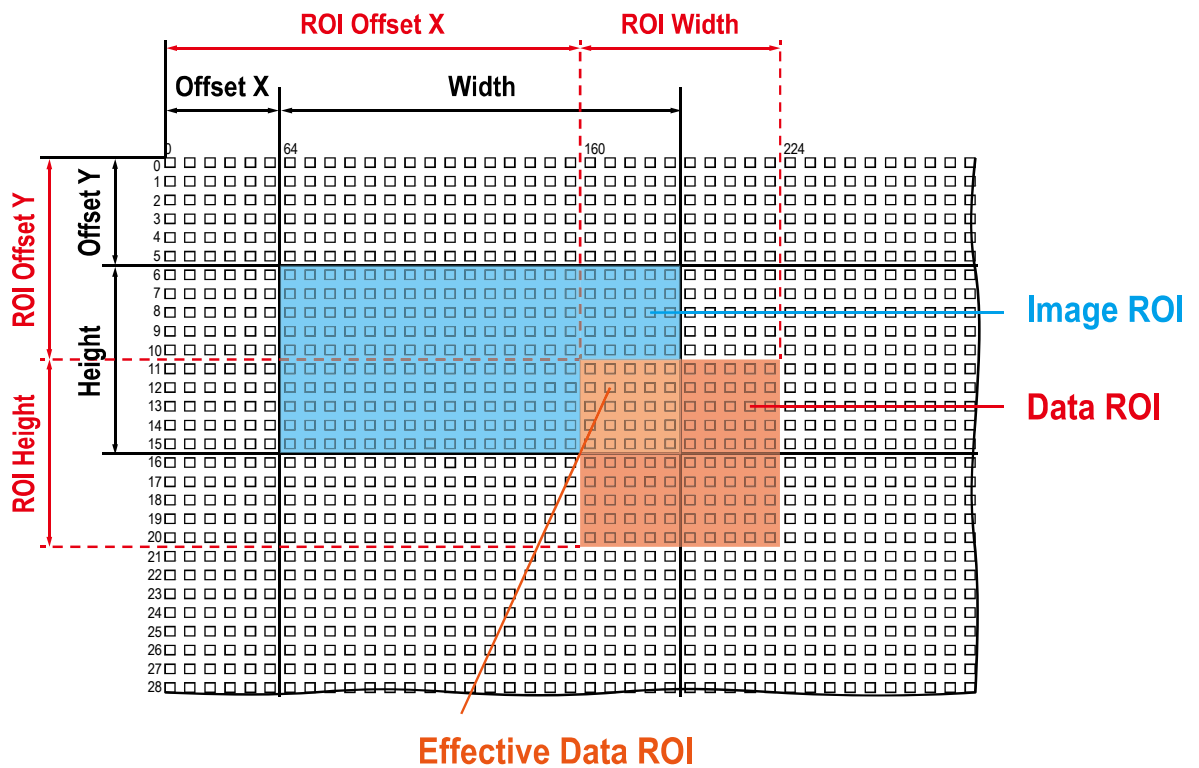

Figure 9-7 Effective Data ROI

9.8 White Balance (Color Only)

The color camera includes the white balance capability to adjust the color balance of the images transmitted from the camera. With the white balancing scheme used on the VC-25MC-31 I camera, the Red, Green and Blue intensities can be adjusted individually. You can set the intensity of each color by using the Balance Ratio parameter. The Balance Ratio value can range from 1.0 to 4.0. If the Balance Ratio parameter is set to 1.0 for a color, the intensity of the color will be unaffected by the white balance mechanism. If the Balance Ratio parameter is set to greater than 1.0, the intensity of the color will be proportionally increased to the ratio. For example, if the Balance Ratio is set to 1.5, the intensity of that color will be increased by 50%. The XML parameters related to White Balance are as follows.

| XML Parameters | | Value | Description |
|----------------|-----------------------|-------------|--|
| AnalogControl | BalanceRatio Selector | Red | A Balance Ratio value will be applied to red pixels. |
| | | Green | A Balance Ratio value will be applied to green pixels. |
| | | Blue | A Balance Ratio value will be applied to blue pixels. |
| | BalanceRatio | ×1.0 ~ ×4.0 | Adjusts the ratio of the selected color. |

Table 9-14 XML Parameters related to White Balance

9.8.1 Balance White Auto

The Balance White Auto feature is implemented on the color camera. It will control the white balance of the image acquired from the color camera according to the GreyWorld algorithm. Before using the Balance White Auto feature, you need to set the Data ROI for Balance White Auto. If you do not set the related Data ROI, the pixel data from the Image ROI will be used to control the white balance. As soon as the Balance White Auto parameter is set to Once, the Balance Ratio values for Red and Blue will be automatically adjusted to adjust the white balance by referring to Green.

The XML parameters related to Balance White Auto are as follows.

| XML Parameter | | Value | Description |
|---------------|-------------------|-------|--|
| AnalogControl | BalanceWhite Auto | Off | Balance White Auto Off |
| | | Once | White Balance is adjusted once and then Off. |

Table 9-15 XML Parameter related to Balance White Auto

9.9 Gain and Black Level

Increasing the Gain parameter increases all pixel values of the image. This results in a higher grey value output from the camera for a given amount of output from the image sensor.

1. Selects the Gain Control (Analog All, Digital All) to be adjusted by using the Gain Selector parameter.
2. Sets the Gain parameter to the desired value.

Adjusting the Black Level parameter will result in an offset to the pixel values output from the camera.

1. Selects the Black Level Control (Digital All is only available) to be adjusted by using the Black Level Selector parameter.
2. Sets the Black Level parameter to the desired value.

The XML parameters related to Gain and Black Level are as follows.

| XML Parameters | Value | Description |
|--------------------|------------------------|--|
| AnalogControl | GainSelector | Analog All |
| | | Digital All |
| Gain | | Applies the Gain value to all analog channels. |
| | | Applies the Gain value to all digital channels. |
| | 1.0×, 1.3×, 2.0×, 4.2× | Sets an analog gain value. |
| BlackLevelSelector | | Sets an analog gain value when 2×2 binning in sensor. |
| | | Sets a digital gain value. |
| | 1.0× — 32.0× | Applies the Black Level value to all digital channels. |
| BlackLevel | Digital All | Sets a black level value. |
| | 8 bit: 0 ~ 15.93 | |
| | 10 bit: 0 ~ 63.75 | |
| | 12 bit: 0 ~ 255.00 | |

Table 9-16 XML Parameters related to Gain and Black Level

9.10 Defective Pixel Correction

The CMOS sensor may have defect pixels which cannot properly react to the light. Correction is required since it may deteriorate the quality of output image. Defect pixel information of CMOS used for each camera is entered into the camera during the manufacturing process. If you want to add defect pixel information, it is required to enter coordinate of new defect pixel into the camera. For more information, refer to Appendix A.

9.10.1 Correction Method

A correction value for a defect pixel is calculated based on the valid pixel value adjacent in the same line.

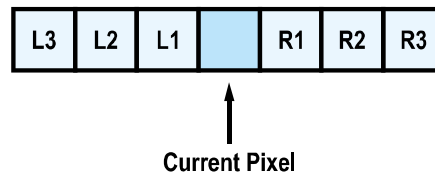

Figure 9-8 Location of Defect Pixel to be corrected

If the Current Pixel is a defect pixel as shown in the figure above, the correction value for this pixel is obtained as shown in the following table depending on whether surrounding pixels are defect pixels or not.

| Adjacent Defect Pixel | Correction Value of Current Pixel |
|-----------------------|-----------------------------------|
| None | $(L1 + R1) / 2$ |
| L1 | R1 |
| R1 | L1 |
| L1, R1 | $(L2 + R2) / 2$ |
| L1, R1, R2 | L2 |
| L2, L1, R1 | R2 |
| L2, L1, R1, R2 | $(L3 + R3) / 2$ |
| L2, L1, R1, R2, R3 | L3 |
| L3, L2, L1, R1, R2 | R3 |

Table 9-17 Calculation of Defect Pixel Correction Value

9.11 Dark Signal Non-uniformity Correction

In theory, when a digital camera acquires images in complete darkness, all the pixel values in the image should be near zero and they should be equal. In practice, however, slight variations in the performance of the pixels in the sensor will cause some variations in the pixel values output from the camera when the camera is acquiring in darkness. This variation is known as Dark Signal Non-uniformity (DSNU). The VC-21MDF-M/C460I cameras provide the DSNU Correction feature.

The XML parameters related to DSNU are as follows.

| XML Parameters | | Value | Description |
|----------------|------------------|------------|--|
| DSNU | DSNUDataSelector | Default | Selects Default as a non-volatile memory location to generate/save/load DSNU data from. |
| | | Space1 - 7 | Selects a user defined location as a non-volatile memory location to save DSNU data to or load DSNU data from. |
| | DSNUDataGenerate | - | Generates the DSNU data for the current camera settings. |
| | DSNUDataSave | - | Saves the generated DSNU data in the non-volatile memory: The generated data by executing the DSNUDataGenerate command are saved in the volatile memory so that the data are lost if the camera is reset or if power is turned off. To use the data after the camera is powered on or reset, save them in the non-volatile memory. |
| | DSNUDataLoad | - | Loads the DSNU data from the non-volatile memory into the volatile memory. |
| | DSNUDataDefault | Default | Selects the DSNU data saved in the Default parameter as the default setting of the DSNU data. |
| | | Space1 - 7 | Selects the default of the DSNU-data location among the saved data. |

Table 9-18 XML Parameters related to DSNU

9.11.1 Generating and Saving User DSNU Correction Values

To generate and save user DSNU correction values, use the following procedure.



Note:

- For optimum DSNU correction results, we recommend that you generate DSNU data after the temperature of the camera housing has been stabilized.
 - Before generating DSNU data, set the FFC feature to Off.
-

1. To obtain the optimum DSNU correction values, set the ROI to the actual settings you will be using during normal operation.
2. Ensure that the camera will be acquiring images in complete darkness by covering the camera lens, closing the iris in the lens, or darkening the room.
3. Begin acquiring images by setting the camera for the Free-Run mode.
4. Execute the DSNU Data Generate command to generate DSNU data for the current camera settings.
5. The generated DSNU correction values will be activated and saved in the camera's volatile memory.
6. To save the generated DSNU correction values in the camera's Flash (non-volatile) memory, use the DSNU Data Selector parameter to specify a location to save the DSNU correction values, and then execute the DSNU Data Save command. The previous DSNU values saved in the memory will be overwritten.

To disregard the generated DSNU correction values and load the existing values in the Flash memory, use the DSNU Data Selector parameter to select a desired DSNU correction value, and then execute the DSNU Data Load command.

9.12 Photo Response Non-uniformity Correction

In theory, when a line scan camera acquires images with the camera viewing a uniform light-colored target in bright light, all of the pixel values in the image should be near the maximum grey value and they should be equal. In practice, however, slight variations in the performance of the pixels in the sensor, variations in the optics, and variations in the lighting will cause some variations in the pixel values output from the camera. This variation is known as Photo Response Non-uniformity (PRNU). The VC-21MDF-M/C460I cameras provide the PRNU Correction feature.

The XML parameters related to PRNU are as follows.

| XML Parameters | | Value | Description |
|----------------|--------------------|---|--|
| PRNU | PRNUNUDataSelector | Default | Selects Default as a non-volatile memory location to load PRNU data from. |
| | | Space1 - 7 | Selects a user defined location as a non-volatile memory location to save PRNU data to or load PRNU data from. |
| | PRNUDataGenerate | - | Generates the PRNU data for the current camera settings. |
| | PRNUDataSave | - | Saves the generated PRNU data in the non-volatile memory. The generated data by executing the PRNUDataGenerate command are saved in the volatile memory so that the data are lost if the camera is reset or if power is turned off. To use the data after the camera is powered on or reset, save them in the non-volatile memory. |
| | PRNUDataDefault | Default | Selects the PRNU data saved in the Default parameter as the default setting of the PRNU data. |
| Space1 - 7 | | Selects the default of the PRNU-data location among the saved data. | |

Table 9-19 XML Parameters related to PRNU

9.12.1 Generating and Saving User PRNU Correction Values

To generate and save user PRNU correction values, use the following procedure.

**Note:**

To generate the optimum PRNU data,

- we recommend that you generate DSNU correction values first before generating PRNU correction values.
- set the FFC feature to Off before generating PRNU correction values.
- the grey reference image must be acquired at uniform illumination. We strongly recommend that you use a high-quality light source to deliver uniform illumination. Standard illumination may not be appropriate.

The PRNU correction values stored in Default are optimized for use in typical situations and will provide good camera performance in most cases. Use of the values stored in Default is recommended.

1. To generate PRNU correction values suitable for your operating conditions, set the ROI to the actual settings you will be using during normal operation. We strongly recommend that you use the Default PRNU correction values stored in Default, if you cannot set up the uniform illumination.
2. Without mounting a lens on the camera, place a uniform illumination (e.g. backlight) in the field of view of the camera. Set up the camera as you would for normal operation. We recommend that you make adjustments to achieve the digital output level in a range from 150 to 200 (Gain: 1.00 at 8 bit).
3. Begin acquiring images by setting the camera for the Free-Run mode.
4. Execute the PRNU Data Generate command to generate PRNU correction values for the current camera settings.
5. The generated PRNU correction values will be activated and saved in the camera's volatile memory.
6. To save the generated PRNU correction values in the camera's Flash (non-volatile) memory, use the PRNU Data Selector parameter to specify a location to save the PRNU correction values, and then execute the PRNU Data Save command. The previous PRNU values saved in the memory will be overwritten.

To disregard the generated PRNU correction values and load the existing values in the Flash memory, use the PRNU Data Selector parameter to select a desired PRNU correction value, and then execute the PRNU Data Load command.

9.13 Flat Field Correction

The Flat Field Correction feature improves the image uniformity when you acquire a non-uniformity image due to external conditions. The Flat Field Correction feature of the VC-21MDF-M/C460I camera can be summarized by the following equation.

$$IC = IR / IF$$

IC: Level value of corrected image

IR: Level value of original image

IF: Level value of Flat Field data

In actual use conditions, generate a Flat Field correction data and then save the data into the non-volatile memory of the camera by following the procedure below.

1. Execute the Flat Field Data Generate parameter.

After executing the Flat Field Data Generate parameter, you must acquire one image to generate the scaled down Flat Field correction data.

2. Use the Flat Field Data Selector parameter to specify a location to save the generated Flat Field correction data.
3. Execute the Flat Field Data Save parameter to save the generated Flat Field data into the non-volatile memory. When the scaled down Flat Field data are used for correction, they are expanded and applied with a Bilinear Interpolation as shown in the Figure 9-10.

To disregard the generated Flat Field correction data and load the existing Flat Field correction data, execute the Flat Field Data Load parameter before executing the Flat Field Data Save parameter.

4. Set the Flat Field Correction parameter to On to apply the Flat Field data to the camera.



Caution!

- It is recommended that you enable the Defective Pixel Correction feature before executing the Flat Field Data Generate parameter.
- Before executing the Flat Field Data Generate parameter, you must set the camera as follows:
OffsetX, Y: 0
Width, Height: Maximum values
- After executing the Acquisition Start command, you need to operate the camera with the free-run mode or apply a trigger signal to acquire an image.

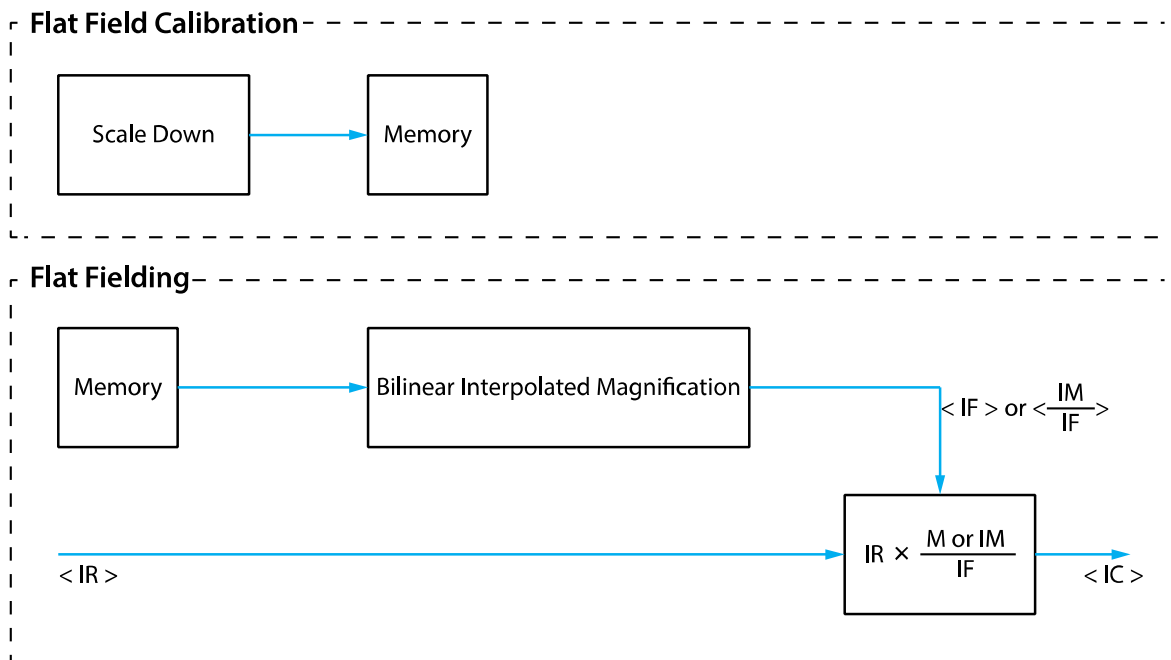

Figure 9-9 Generation and Application of Flat Field Data

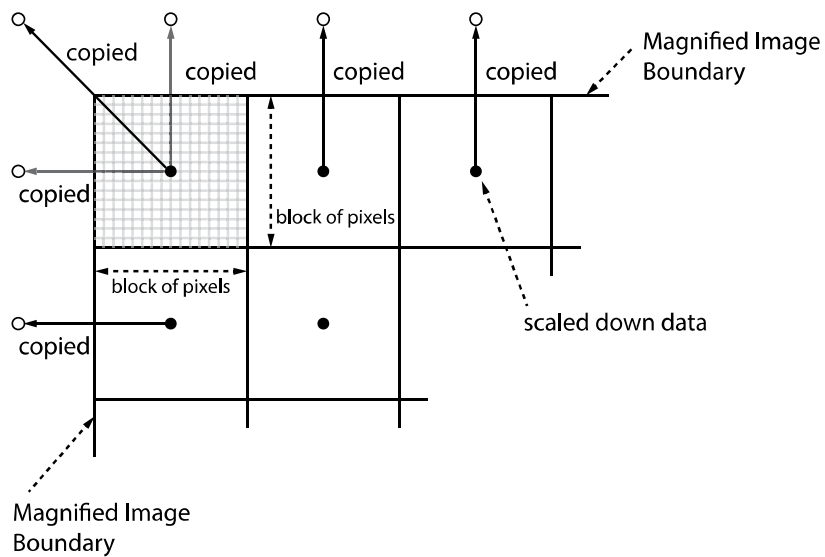

Figure 9-10 Bilinear Interpolated Magnification

The XML parameters related to Flat Field Correction are as follows.

| XML Parameters | Value | Description |
|--------------------------------------|------------------|--|
| FlatFieldControl FlatFieldCorrection | Off | Disables the Flat Field Correction feature. |
| | On | Enables the Flat Field Correction feature. |
| FlatFieldData Selector | Space0 ~ Space15 | Selects a location to save Flat Field data to or load Flat Field data from. Space0~Space15: User defined location |
| FlatFieldData Generate | - | Generates the Flat Field data. |
| FlatFieldDataSave | - | Saves the generated Flat Field correction data in the non-volatile memory: The data generated by executing the Flat Field Data Generate parameter are saved in the volatile memory so that the data are lost if the camera is reset or if power is turned off. To use the data after the camera is powered on or reset, save them in the non-volatile memory. |
| FlatFieldDataLoad | - | Loads the Flat Field data from the non-volatile memory into volatile memory. |
| FlatFieldDataDefault | Space0 ~ Space15 | Selects the default location of the Flat Field data among the saved data. Space0~Space15: User defined location |

Table 9-20 XML Parameters related to Flat Field Correction

9.13.1 Flat Field Data Selector

As mentioned above, the generated Flat Field correction data are stored in the camera's volatile memory and the data are lost if the camera is reset or powered off. To use the generated Flat Field correction data after the camera is powered on or reset, you need to save them in the camera's non-volatile memory. The VC-21MDF-M/C460I camera provides sixteen reserved locations in the camera's non-volatile memory available for saving and loading the Flat Field correction data. You can use the Flat Field Data Selector parameter to select a location as desired.

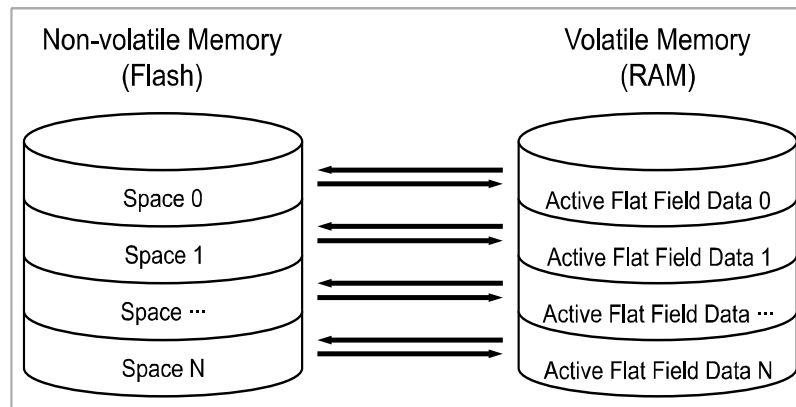

Figure 9-11 Flat Field Data Selector

Saving Flat Field Data

In order to save the active Flat Field data into a reserved location in the camera's Flash memory, follow the procedure below.

1. Use the Flat Field Data Selector parameter to specify a location to save the active Flat Field data.
2. Execute the Flat Field Data Save parameter to save the active Flat Field data to the selected location.

Loading Flat Field Data

If you saved Flat Field correction data into the camera's non-volatile memory, you could load the saved Flat Field correction data from the camera's non-volatile memory into the camera's active Flat Field data location.

1. Use the Flat Field Data Selector parameter to specify a reserved location whose Flat Field correction data will be loaded into the camera's active Flat Field data location.
2. Execute the Flat Field Data Load parameter to load the selected Flat Field correction data into the active Flat Field data location.

9.14 Timestamp

VC-21MDF-M/C460I camera provides a Timestamp feature.

XML parameters related to Timestamp are as follows.

| XML Parameters | Description |
|-------------------------|--|
| DeviceControl Timestamp | Indicates the current Timestamp value of the connected device. |
| TimestampIncrement | Indicates the increment of Timestamp. |
| TimestampReset | Changes the current Timestamp value into 0 and restarts counting. |
| TimestampResetValue | Designates time to reset Timestamp as 0, by the form in the numeric value. |
| TimestampLatch | Latches the current value of Timestamp. |
| TimestampLatchValue | Indicates prior value before resetting the Timestamp value. |

Table 9-21 XML Parameters related to Timestamp

9.15 Event Control

VC-21MDF-M/C460I camera provides an Event Notification feature. With the Event Notification feature, the camera can generate an event and transmit a related event message to the PC whenever a specific situation has occurred.

The VC-21MDF-M/C460I camera can generate and transmit events for the following type of situation:

- When the TestEventGenerate parameter is executed (Test)

XML parameters related to Event Control are as follows.

| XML Parameters | Value | Description | |
|----------------|--------------------|-------------|---|
| EventControl | EventSelector | Test | Transfers the Test event generated from the execution of the TestEventGenerate parameter. |
| | Event Notification | On | Enables the selected event notification. |
| | | Off | Disables the selected event notification. |
| TestControl | TestPendingAck | - | Sets time to wait before writing the device's pending acknowledge feature. |
| | TestEventGenerate | - | Generates a Test event. |

Table 9-22 XML Parameters related to Event Control

9.16 Digital I/O Control

The Control I/O receptacle of the camera can be operated in various modes.

The XML parameters related to Digital I/O Control are as follows.

| XML Parameters | Value | Description | |
|------------------|------------------|---------------------|--|
| DigitalIOControl | LineSelector | Line0 | Configures the pin of No.1 among 12 pins of the camera's Power Input and Control I/O receptacle. |
| | | Line1 ~ Line6 | Configures the pin of No. 4, 7, 8, 9, 10 or 11 among 12 pins of the camera's Power Input and Control I/O receptacle. |
| | LineMode | Input | Appears under Line0 is chosen. |
| | | Output | Appears under one of the Line1~Line6 is chosen. |
| | LineInverter | FALSE | Disables inversion on the output signal of the line. |
| | | TRUE | Enables inversion on the output signal of the line. |
| | LineSource | Off | Disables the line output. |
| | | Frame Active | Outputs pulse signals indicating a frame readout time. |
| | | LineActive | Outputs pulse signals indicating the current line time. |
| | | Exposure Active | Outputs pulse signals indicating the current exposure time. |
| | | UserOutput0 | Outputs pulse signals set by User Output Value. |
| | | Timer0 Active | Outputs user-defined Timer signals as pulse signals. |
| | | Count0Active | Outputs user-defined Counter signals as pulse signals |
| | | UserOutput Selector | UserOutput0 |
| | UserOutput Value | FALSE | Sets the bit state of the line to Low. |
| | | TRUE | Sets the bit state of the line to High. |
| | Debounce Time | 0 ~ 1,000,000 | Sets a Debounce Time in microseconds (Default: 0.5 μ s). |

Table 9-23 XML Parameters related to Digital I/O Control

When you set the Line Source to UserOutput0, you can use the user setting values as output signals.

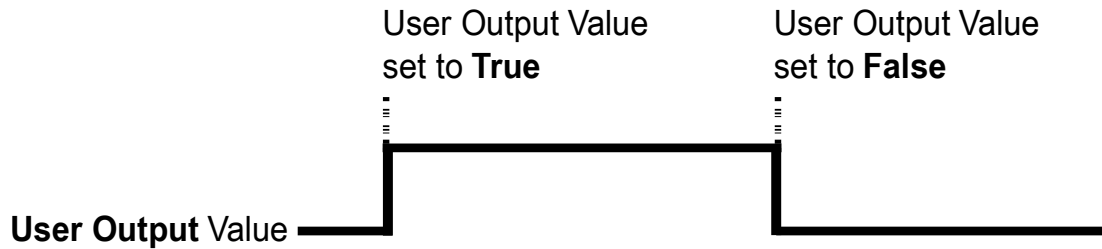

Figure 9-12 User Output

The camera can provide an Exposure Active output signal. The signal goes high when the exposure time for each frame acquisition begins and goes low when the exposure time ends as shown in the figure below. This signal can be used as a flash trigger and is also useful when you are operating a system where either the camera or the object being imaged is movable. Typically, you do not want the camera to move during exposure. You can monitor the Exposure Active signal to know when exposure is taking place and thus know when to avoid moving the camera.

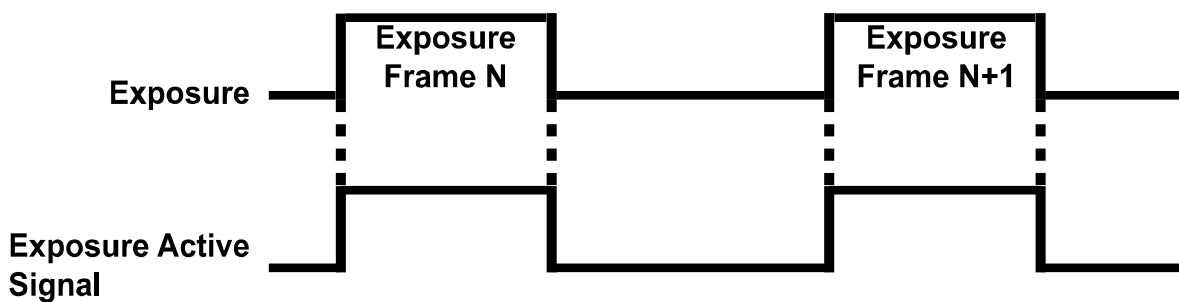

Figure 9-13 Exposure Active Signal

9.17 Debounce

The Debounce feature of the VC-21MDF-M/C460I cameras allows to supply only valid signals to the camera by discriminating between valid and invalid input signals. The Debounce Time parameter specifies the minimum time that an input signal must remain High or Low in order to be considered as a valid input signal. When you use the Debounce feature, be aware that there is a delay between the point where the valid input signal arrives and the point where the signal becomes effective. The duration of the delay is determined by the Debounce Time parameter setting value.

When you set the Debounce Time parameter, High and Low signals shorter than the setting value are considered invalid and ignored as shown in the figure below.

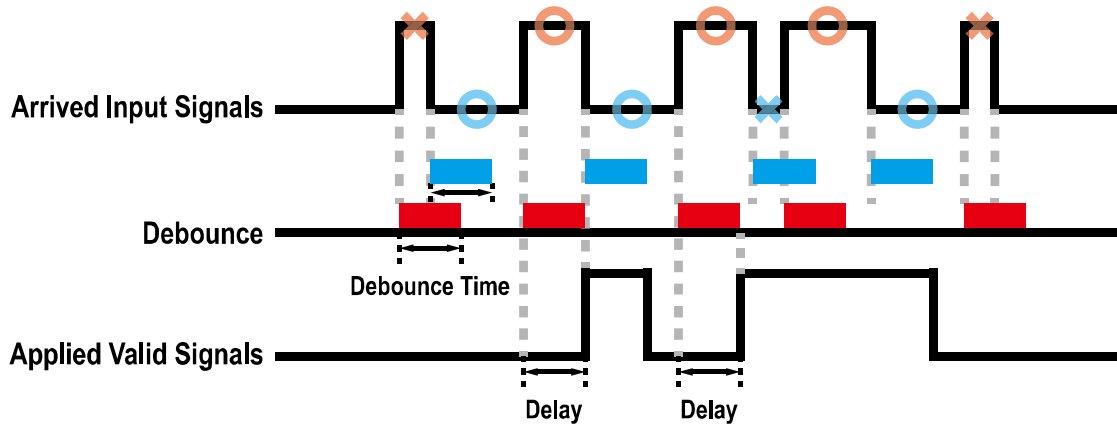

Figure 9-14 Debounce

The XML parameter related to Debounce Time is as follows.

| XML Parameters | | Value | Description |
|------------------|---------------|-----------------------|--|
| DigitalIOControl | Debounce Time | 0 – 1,000,000 μ s | Sets a Debounce Time in microseconds (Default: 0 μ s). |

Table 9-24 XML Parameter related to Debounce Time

9.18 Counter Control

The VC-21MDF-M/C460I camera provides the Counter feature to count certain camera events. For example, you can verify the number of external trigger signals applied to the camera.

The XML parameters related to Counter Control are as follows.

| XML Parameters | Value | Description | |
|----------------------------|--------------------|---|---------------------------------|
| CounterAnd TimerControl | CounterSelector | Counter0 | Selects a Counter to configure. |
| | CounterEventSource | Off | Stops the Counter. |
| FrameActive | | Counts the number of FrameActive signals. | |
| LineActive | | Counts the number of Line Active signals. | |
| Exposure Active | | Counts the number of Exposure Active signals. | |
| LinkTrigger0 | | Counts the number of LinkTrigger0 signals. | |
| Line0 | | Counter the number of external trigger signals. | |
| CounterEvent Activation | RisingEdge | Counts on the rising edge of the selected Event Source signal. | |
| | FallingEdge | Counts on the falling edge of the selected Event Source signal. | |
| CounterResetSource | Off | Disables the Counter Reset trigger. | |
| | Frame Active | Uses the Frame Active signal as Reset Source. | |
| | Exposure Active | Uses the Exposure Active signal as Reset Source. | |
| | Acquisition Active | Uses the Acquisition Active signal as Reset Source. | |
| | Line0 | Uses the Line0 signal as Reset Source. | |
| CounterReset Activation | RisingEdge | Resets Counter on the rising edge of the selected Reset Source signal. | |
| | FallingEdge | Resets Counter on the falling edge of the selected Reset Source signal. | |
| | AnyEdge | Resets Counter on the rising/falling edge of the selected Reset Source signal. | |
| | LevelHigh | Resets the Counter if the level of the selected Reset Source signal is High. | |
| | LevelLow | Resets the Counter if the level of the selected Reset Source signal is Low. | |
| CounterReset | - | Resets the selected Counter and restarts. | |
| CounterValue | - | Displays the current value of the selected Counter. | |
| CounterValueAtReset | - | Displays the value of the Counter when it was reset by the Counter Reset command. | |

Table 9-25 XML Parameters related to Counter Control # 1

| XML Parameters | Value | Description | |
|----------------------------|--------------------------|---|--|
| CounterAnd TimerControl | CounterDuration | 1 – 4294967295 | Sets the duration or number of events to count before the Counter ends. |
| | CounterStatus | - | Displays the current status of the Counter. |
| | CounterTriggerSource | Off | Disables the Counter Trigger Source function. |
| | | Frame Active | Uses the Frame Active signal as Trigger Source of Counter. |
| | | Exposure Active | Uses the Exposure Active signal as Trigger Source of Counter. |
| | | Acquisition Active | Uses the Acquisition Active signal as Trigger Source of Counter. |
| | | Line0 | Uses the Line0 signal as Trigger Source of Counter. |
| | CounterTriggerActivation | RisingEdge | Starts Counter on the rising edge of the selected Counter Trigger Source signal. |
| | | FallingEdge | Starts Counter on the falling edge of the selected Counter Trigger Source signal. |
| | | AnyEdge | Starts Counter on the rising/falling edge of the selected Counter Trigger Source signal. |
| LevelHigh | | Resets the Counter if the level of the selected Counter Trigger Source signal is High. | |
| LevelLow | | Resets the Counter if the level of the selected Counter Trigger Source signal is Counter. | |

Table 9-26 XML Parameters related to Counter Control #2

9.19 Timer Control

When the Line Source parameter is set to Timer0Active, the camera can provide output signals by using the Timer. On the VC-21MDF-M/C460I camera, the Frame Active, Exposure Active event or external trigger signal is available as Timer source signal.

The XML parameters related to Timer are as follows.

| XML Parameters | Value | Description |
|----------------------------|----------------|--|
| CounterAnd TimerControl | TimerDuration | 1 ~ 85,899,344 μ s Sets the duration of the Timer output signal to be used when Timer Trigger Activation is set to Rising/Falling Edge. |
| | TimerDelay | 0 ~ 85,899,344 μ s Sets the delay time to be applied before starting the Timer. |
| | TimerReset | - Resets the Timer and starts it again. |
| TimerTrigger Source | Off | Disables the Timer trigger. |
| | ExposureActive | Sets the Timer to use the current exposure time as the source signal. |
| | FrameActive | Sets the Timer to use a frame readout time as the source signal. |
| | Line0 | Sets the Timer to use the external trigger signal as the source signal. |
| | Counter0Start | Outputs user-defined Counter signals as pulse signals. |
| TimerTrigger Activation | RisingEdge | Specifies that a rising edge of the selected trigger signal will act as the Timer trigger. |
| | FallingEdge | Specifies that a falling edge of the selected trigger signal will act as the Timer trigger. |
| | LevelHigh | Specifies that the Timer output signal will be valid as long as the selected trigger signal is High. |
| | LevelLow | Specifies that the Timer output signal will be valid as long as the selected trigger signal is Low. |

Table 9-27 XML Parameters related to Timer Control

For example, when the Timer Trigger Source is set to Exposure Active and the Timer Trigger Activation is set to Level High, the Timer will act as follows.

1. When the source signals set by the Timer Trigger Source parameter are applied, the Timer will start operations.
2. The delay set by the Timer Delay parameter begins to expire.
3. When the delay expires, the Timer signal goes high as long as the source signal is high.

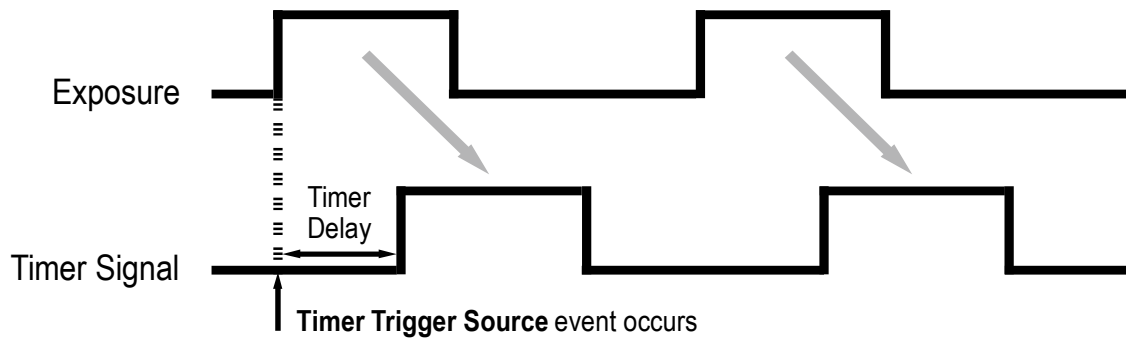

* Timer Trigger Activation is set to Level High.

Figure 9-15 Timer Signal

9.20 Cooling Control

A fan is installed on the rear panel of the camera to radiate heat. You can set the fan to turn on or off. You can also set the fan to turn on when a specified internal temperature is reached.

The XML parameters related to Cooling Control are as follows.

| XML Parameters | Value | Description |
|-------------------|--------------|--|
| TargetTemperature | -10°C ~ 80°C | Turns on the fan automatically when the temperature set in this parameter. |
| CoolingControl | Off | Turns off the fan. |
| | On | Turns on the fan. |
| | Temperature | Turns on the fan when the internal temperature exceeds the value set in the TargetTemperature parameter. |
| FanSpeed | - | Displays the current Fan RPM. |

Table 9-28 XML Parameters related to Cooling Control

9.21 Temperature Monitor

The camera has an embedded sensor chip to monitor the internal temperature.

The XML parameters related to Device Temperature are as follows.

| XML Parameters | Value | Description |
|----------------|---------------------------|--|
| DeviceControl | DeviceTemperatureSelector | Mainboard Sets a temperature measuring spot to the mainboard. |
| | DeviceTemperature | - Displays device temperature in Celsius. |

Table 9-29 XML Parameters related to Device Temperature



Partial Shutdown

It is recommended to keep the temperature of the camera's face plate below +55°C, and to keep the internal temperature below 65°C, for stable operation. On some environment unable to use cooling devices such as fans, the camera's temperature will get hotter at the same time if the temperature of convection becomes hot. When the temperature inside the camera exceeds +75°C±2, the camera activates a Partial Shutdown mode to protect the product. In this case, it is available to send commands to the camera, however, images will not be acquired, and the camera's power will be reduced to about 70% of the normal operating standard.

To recover from partial shutdown mode, turn off the camera and allow the camera to cool sufficiently before operating again.

9.22 Status LED

A LED is installed on the rear panel of the camera to inform the operation status of the camera.

LED status and corresponding camera status are as follows:

| Status LED | Description |
|----------------------|---|
| Steady Red | The camera is not initialized. |
| Slow Flashing Red | A CXP Link is not configured. |
| Fast Flashing Red | Camera is on the partial shutdown mode due to its temperature exceeding the recommendation. |
| Fast Flashing Orange | The camera is checking a CXP Link configuration. |
| Steady Green | A CXP Link is configured. |
| Fast Flashing Green | The camera is transmitting image data. |

Table 9-30 Status LED

9.23 Test Pattern

To check whether the camera operates normally or not, it can be set to output test patterns generated in the camera, instead of image data from the image sensor. Four types of test patterns are available; images with different values in horizontal direction (Grey Horizontal Ramp), images with different values in diagonal direction (Grey Diagonal Ramp), moving images with different values in diagonal direction (Grey Diagonal Ramp Moving) and images with different values in horizontal direction output from the image sensor (Sensor Specific).

The XML parameter related to Test Pattern is as follows.

| XML Parameter | Value | Description |
|------------------------|------------------------|---|
| ImageFormat Control | Off | Disables the Test Pattern feature. |
| | GreyHorizontalRamp | Sets to Grey Horizontal Ramp. |
| | GreyDiagonalRamp | Sets to Grey Diagonal Ramp. |
| | GreyDiagonalRampMoving | Sets to Grey Diagonal Ramp Moving. |
| | SensorSpecific | Sets to the Test Pattern generated by the image sensor. |

Table 9-31 XML Parameter related to Test Pattern



Figure 9-16 Grey Horizontal Ramp

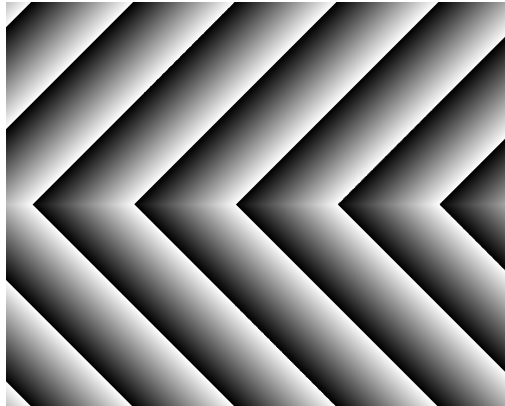

Figure 9-17 Grey Diagonal Ramp



Figure 9-18 Grey Diagonal Ramp Moving

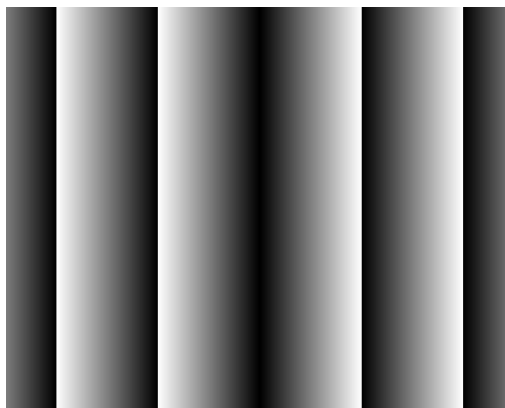

Figure 9-19 Sensor Specific



Caution!

The test pattern may look different because the region of the test pattern may vary depending on the camera's resolution.

9.24 Reverse X

The Reverse X feature lets you flip images horizontally. This feature is available in almost all of operation modes of the camera, except for the Test Image mode.

| XML Parameter | | Value | Description |
|--------------------|----------|-------|---------------------------------|
| ImageFormatControl | ReverseX | FALSE | Disables the Reverse X feature. |
| | | TRUE | Flips images horizontally. |

Table 9-32 XML Parameter related to Reverse X



Figure 9-20 Original Image



Figure 9-21 Reverse X Image

9.25 Device Link Throughput Limit

The Device Link Throughput Limit feature allows you to limit the maximum available bandwidth for data transmission to your computer.

The XML parameter related to Device Link Throughput Limit is as follows.

| XML Parameters | Description |
|---|---|
| DeviceControl DeviceLinkThroughputLimit | Limits the maximum available bandwidth (Bps). |

Table 9-33 XML Parameter related to Device Link Throughput Limit



Caution!

To ensure good image quality, we recommend that you set the Device Link Throughput Limit parameter to the maximum value. Otherwise, the image quality can decrease. In case of the VC-21MDF-M/C460I, its maximum value is 120000.

9.26 Device User ID

You can input user-defined information up to 32 bytes.

The XML parameter related to Device User ID is as follows.

| XML Parameter | Description |
|----------------------------|--|
| DeviceControl DeviceUserID | Input user-defined information (32 bytes). |

Table 9-34 XML Parameter related to Device User ID

9.27 Device Reset

Resets the camera physically to power off and on.

The XML parameter related to Device Reset is as follows.

| XML Parameter | Description |
|---------------------------|-------------------------------|
| DeviceControl DeviceReset | Resets the camera physically. |

Table 9-35 XML Parameter related to Device Reset

9.28 Field Upgrade

The camera provides a feature to upgrade the Firmware and FPGA logic through the Camera Link interface without disassembling the camera in the field. Refer to Appendix A for more details about how to upgrade.

9.29 User Set Control

You can save the current camera settings to the camera's internal Flash memory. You can also load the camera settings from the camera's internal Flash memory. The camera provides two setups to save and three setups to load settings.

The XML parameters related to User Set Control are as follows.

| XML Parameters | Value | Description |
|-----------------|----------------|--|
| UserSetSelector | Default | Selects the Factory Default settings. |
| | UserSet1 | Selects the UserSet1 settings. |
| | UserSet2 | Selects the UserSet2 settings. |
| UserSetLoad | - | Loads the User Set specified by User Set Selector to the camera. |
| UserSetControl | UserSetSave | Saves the current settings to the User Set specified by User Set Selector. The Default is a Factory Default Settings and allowed to load only. |
| | UserSetDefault | Default |
| UserSet1 | | Applies the UserSet1 when reset. |
| UserSet2 | | Applies the UserSet2 when reset. |

Table 9-36 XML Parameters related to User Set Control

The camera settings stored in the Default can be loaded into the camera's workspace but cannot be changed. The settings set in the workspace will be lost if the camera is reset or powered off. To use the current setting values in the workspace after a reset, you must save the settings to one of the user spaces.

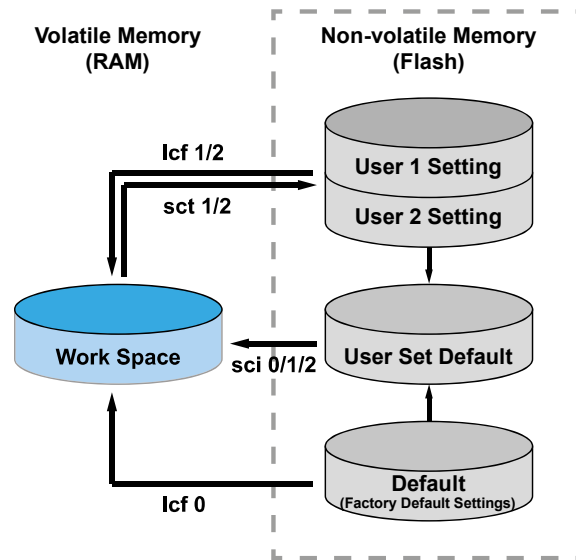

Figure 9-22 User Set Control

9.30 Sequencer Control

The Sequencer Control provided by the VC-21MDF-M/C460I cameras allows you to apply different sets of parameter settings, called 'Sequencer Set', to a sequence of image acquisitions. As the camera acquires images, it applies one Sequencer Set after the other. This allows the camera to respond quickly to changing imaging requirements. For example, if exposure time needs to vary for each shot, it is recommended to configure a sequencer set in advance so that the camera will change the exposure time every time one single shot is taken depending on the setting.

With the User Set Control feature, you can save user defined Sequencer Sets in the camera's non-volatile memory. Then after the camera is powered on or reset, the Sequencer Sets are available according to the User Set Default parameter. Each Sequencer Set is identified by an index number ranging from 0 to 7. Accordingly, you can define up to 8 different Sequencer Sets. On the VC-21MDF-M/C460I cameras, only the Flat Field correction data can be configured for Sequencer Sets.

The XML parameters related to Sequencer Sets are as follows.

| XML Parameters | Value | Description | |
|-----------------------------|-----------------------------|---|---|
| Sequencer Control | SequencerMode | Off On | Disables the Sequencer. Enables the Sequencer. |
| | Sequencer ConfigurationMode | Off On | Disables to configure the Sequencer. Enables to configure the Sequencer. |
| Sequencer FeatureSelector | | FlatFieldData Default | Applies the Flat-Field-data location selected on the FlatFieldDataDefault parameter to the current Sequencer Set. |
| | GainDigitalAll | Applies the value stored on the Gain parameter of DigitalAll to the current Sequencer Set. | |
| | ExposureTime | Applies the value stored on the ExposureTime parameter to the selected Sequencer Set. | |
| Sequencer FeatureEnable | False | Enables the selected feature on SequenceFeatureSelector and to make it active in all the sequencer sets. | |
| | True | Disables the selected feature on SequenceFeatureSelector and to make it inactive in all the sequencer sets. | |
| Sequencer SetSelector | 0 – 7 | Selects an index number of a Sequencer Set to be configured. | |
| SequencerSetSave | - | Saves the current camera's settings to the sequencer set selected on SequencerSetSelector. | |
| SequencerSetLoad | - | Loads the sequencer set selected on SequencerSetSelector and applies it to the current camera. | |
| SequencerSetActive | - | Displays the index number (0 – 7) of the Sequencer Set that is currently active. | |
| SequencerSetStart | 0 - 7 | Indicates the first sequencer set to operate, or designates which sequencer set would be started first as default. | |
| Sequencer PathSelector | 0 - 1 | Selects a path of the current sequencer set being configured/operated. Depending on the path selected here, the sequencer set to be executed next differs, and the number(0-1) of this item indicates the index number of each path. | |
| SequencerSetNext | 0 - 7 | Designates which next sequencer set would be operated after the current one, in the case of a path(Path 0 or Path 1) specified on SequencerPathSelector. | |
| Sequencer TriggerSource | Off | Disables the sequencer trigger. | |
| | Exposure Active | Uses the ExposureActive signal as the sequencer trigger source. | |
| | Frame Active | Uses the FrameActive signal as the sequencer trigger source. | |
| Sequencer TriggerActivation | FallingEdge | Indicates that a sequencer trigger operates on the Falling Edge when using the sequencer trigger. | |

Table 9-37 XML Parameters related to Sequencer Control

Use Case – Applying Four Different Sets of Flat Field Correction Data, Gain and Exposure Time Settings to Sequencer Sets

For example, assume that four different sets of Flat Field correction data, Gain and Exposure settings optimized for White, Green, Red and Blue pixels are applied to four different Sequencer Sets to inspect LCD panels.

1. Set the Sequencer Mode parameter to Off.
2. Select a feature to be applied to Sequencer Sets by using the SequencerFeatureSelector parameter. You must select features to be applied to Sequencer Sets prior to entering the SequencerConfigurationMode.

Set the SequencerFeatureSelector parameter to FlatFieldDataSelector, and then set the SequencerFeatureEnable parameter to True.

Set the SequencerFeatureSelector parameter to GainDigitalAll, and then set the SequencerFeatureEnable parameter to True.

Set the SequencerFeatureSelector parameter to ExposureTime, and then set the SequencerFeatureEnable parameter to True.

3. Set the SequencerConfigurationMode parameter to On.
4. Set the Sequencer Set 0 first, as follows:
 - The SequencerSetSelector parameter: 0
 - The FlatFieldDataSelector parameter in the FlatFieldControl category: Space0
 - The Gain parameter of DigitalALL in the Analog Control category: 1
 - The ExposureTime parameter in the Acquisition Control category: 10000
 - The SequencerSetNext parameter: 1
 - The SequencerPathSelector parameter: 0
 - The SequencerTriggerSource parameter: FrameActive
 - The SequencerTriggerActivation parameter: FallingEdge
 - The SequencerPathSelector parameter: 1
 - The SequencerTriggerSource parameter: Off

5. By referring to the procedure in the step 4 above, set the Sequencer Set 1, Sequencer Set 2 and Sequencer Set 3 also as shown below.

| Step | Parameters | Sequencer Set 1 | Sequencer Set 2 | Sequencer Set 3 |
|------|----------------------------|-----------------|-----------------|-----------------|
| 1 | SequencerSetSelector | 1 | 2 | 3 |
| 2 | FlatFieldDataSelector | Space1 | Space2 | Space3 |
| 3 | DigitalALL, Gain | 2 | 3 | 4 |
| 4 | ExposureTime | 20000 | 30000 | 40000 |
| 5 | SequencerSetNext | 2 | 3 | 0 |
| 6 | SequencerPathSelector | 0 | 0 | 0 |
| 7 | SequencerTriggerSource | FrameActive | FrameActive | FrameActive |
| 8 | SequencerTriggerActivation | FallingEdge | FallingEdge | FallingEdge |
| 9 | PathSelector | 1 | 1 | 1 |
| 10 | SequencerTriggerSource | Off | Off | Off |

6. Set the SequencerConfigurationMode parameter to Off, and then set the SequencerMode parameter to On.

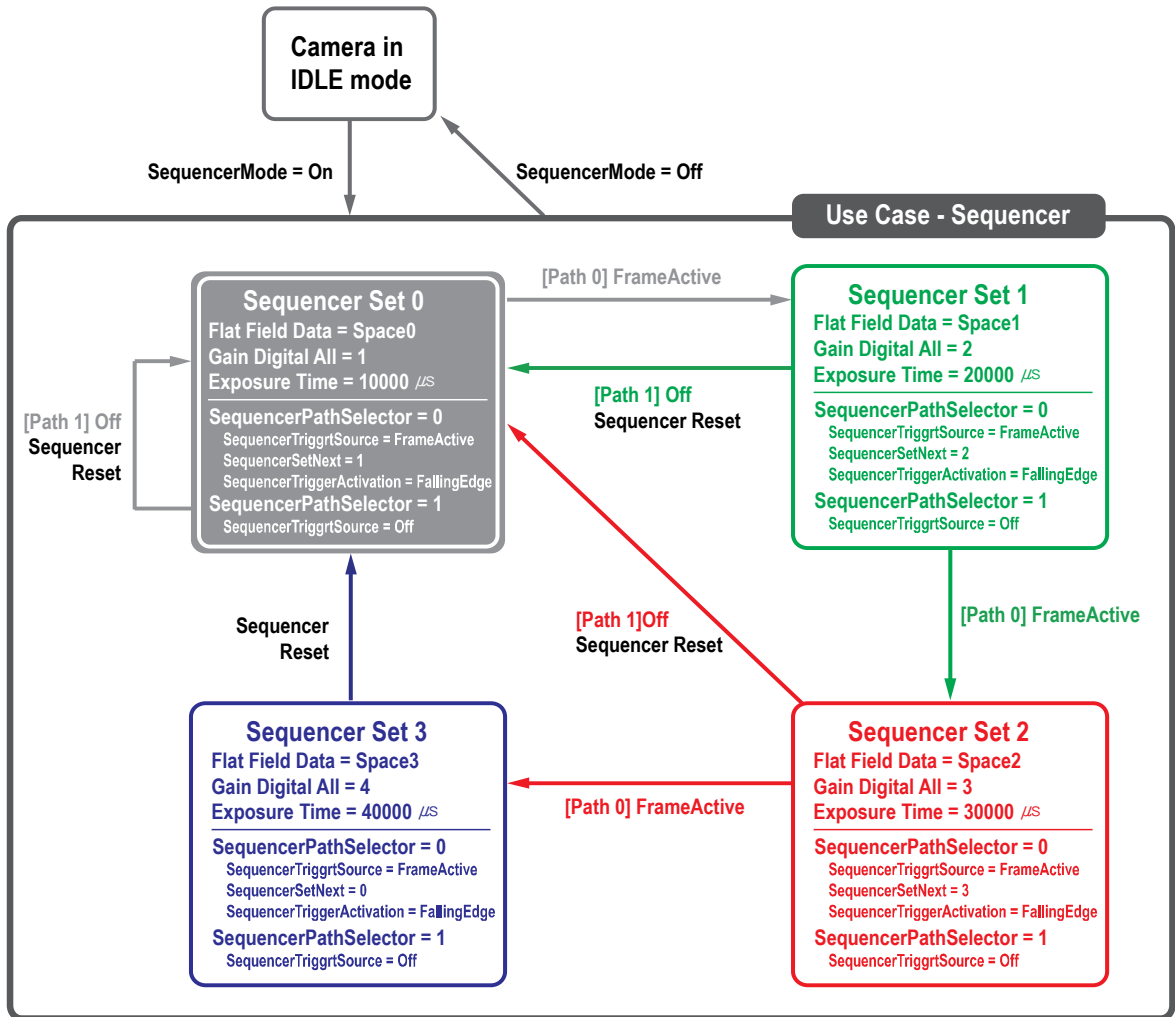

Figure 9-23 Sequencer Diagram (Use Case)



Note:

You can save the user defined Sequencer Sets in the camera's non-volatile memory by using the User Set Control feature. For more information, refer to 9.29 User Set Control.

Chapter 10. Troubleshooting

When you have a problem with a Vieworks camera, please check the followings:

- If no image is displayed on your computer,
 - Ensure that all cable connections are secure.
 - Ensure that the power supply is properly connected.
 - Ensure that trigger signals are applied correctly when you operate the camera with trigger signals.
- If images are not clear,
 - Ensure the camera lens or glass is clean.
 - Check the lens aperture is adjusted properly.
- If images are dark,
 - Ensure the camera lens is not blocked.
 - Check the exposure time is set properly.
- If you identify abnormal operation or overheating sign,
 - Ensure the power supply is properly connected.
 - Stop using the camera when you notice smoke or abnormal overheating.
- If you have a problem using the Trigger Mode,
 - Ensure that the Software trigger related parameters are configured correctly.
 - Ensure that the trigger related parameters on your CoF Frame Grabber are configured correctly when you set the Trigger Source parameter to LinkTrigger0.
 - Ensure that cable connections are secure when you set the Trigger Source parameter to Line 0.
- If there is communication failure between the camera and computer,
 - Ensure cables are connected properly.
 - Ensure that you have configured a CoF Frame Grabber in your computer correctly and the camera is connected properly to the CoF Frame Grabber.

Appendix A. Defective Pixel Map Download

1. Create the Defective Pixel Map data in Microsoft Excel format as shown in the left picture below and save as a CSV file (*.csv). The picture in the right shows the created Excel file opened in Notepad. The following rules need to be applied when creating the file.

- Lines beginning with ':' or '--' are treated as notes.
- You must enter the horizontal value first and then the vertical value for coordinates of each defect pixel.
- Coordinate values for each pixel can be placed in any order.

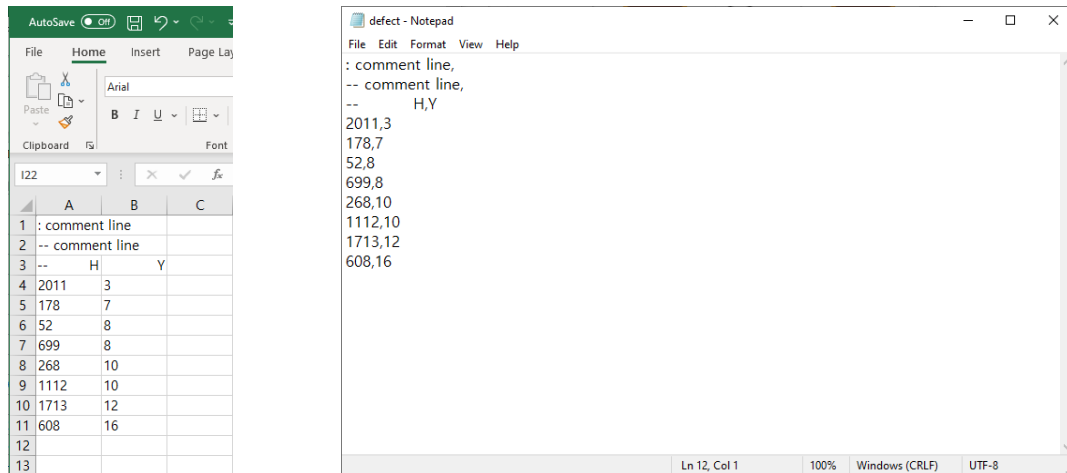

2. Run Vieworks Imaging Solution and click the **Configure** button to display the window as shown below. Select the Defect tab, click the File Path item, search and select the defective pixel map (*.csv), and then click the **Download** button.

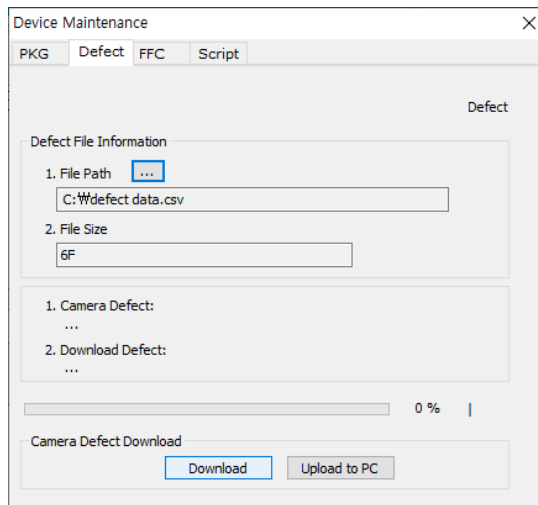

Appendix B. Field Upgrade

You can upgrade the MCU, FPGA and XML file of the camera by following the procedure below.

1. Run Vieworks Imaging Solution 7.X and click the **Configure** button to display the window as shown below.
2. Select the PKG tab, click the button next to File Path, search and select the MCU, FPGA or XML upgrade file, and then click the **Download** button.

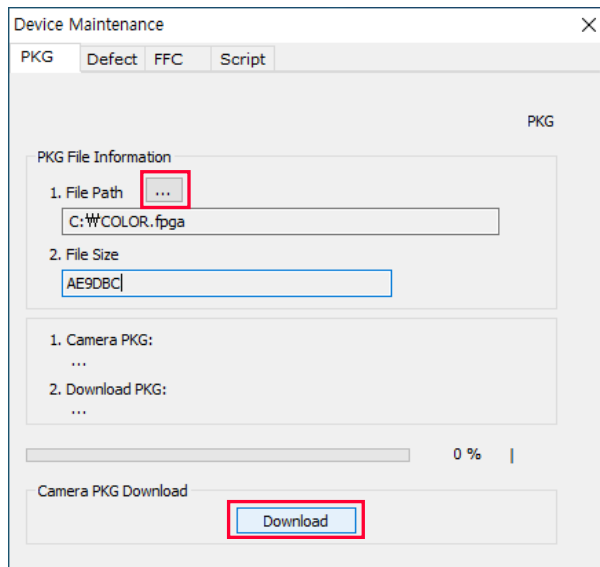

3. The camera begins downloading the upgrade file and the downloading status is displayed at the bottom of the window.

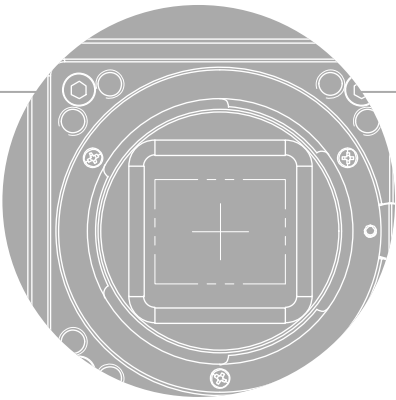
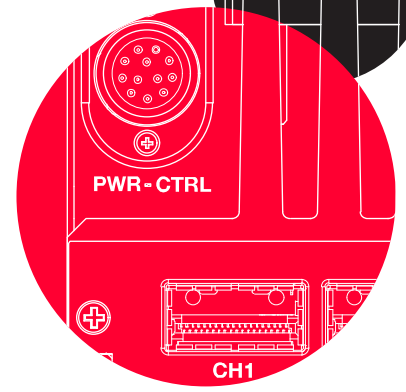
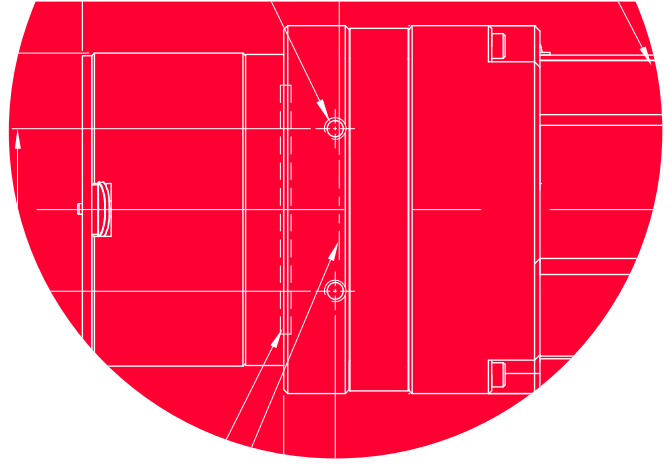

Vieworks Co., Ltd.

41-3, Burim-ro, 170beon-gil,
Dongan-gu, Anyang-si, Gyeonggi-do^L
14055 Republic of Korea

Tel: +82-70-7011-6161

Fax: +82-31-386-8631

<http://vision.vieworks.com>

vision@vieworks.com