

# VP series

## User Manual

English

VP-101MC-M/C 8 H  
VP-151MC-M/C 5 H

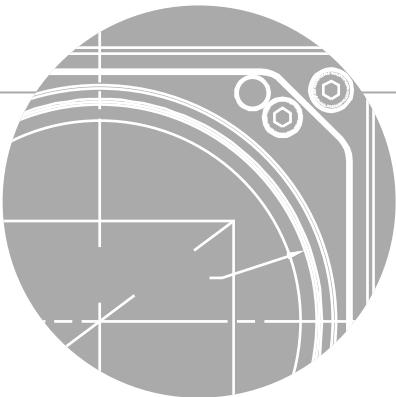

# VIEWWORKS

## Preface

No part of this manual may either be copied, reproduced, translated, or published in any form or by any means (electronic, mechanical, photocopying, or otherwise) without the express written permission of Vieworks, Co., Ltd. (hereinafter 'Vieworks').

This manual may include the website links to companies other than Vieworks. Vieworks is not responsible for any of these links. The copyrights of the materials mentioned herein are owned by each respective author.

Although Vieworks made every effort to ensure the accuracy of this document, it assumes no responsibility for errors or omissions that may appear herein. The figures in this manual may differ depending on the version of the product or operating system, or the way how it runs. Information in this manual is subject to change without notice.

## Before Using This Product

Thank you for choosing VP-101MC/151MC™.

- Make sure to read this manual before using the product.
- Make sure to check whatever a professional engineer has finished installation and configuration.
- Make sure to keep this manual at hand as a reference while using the product.
- This manual assumes that you have expertise in how to use an industrial camera.

## The Series

This manual is intended for users of the following products:

- VP-101MC/151MC

## About This Manual

This manual is intended for VP-101MC/151MC™ camera users. It is recommended to refer to the Frame Grabber's User Manual of yours, with this manual.

## Convention in This Manual

For better understanding, the following conventions are used throughout the manual.

### Names and Fonts

The names and fonts of user interfaces are used as follows:

- The menu and icon names in this manual are used as displayed in the product.
- The menu and icon names are marked in this font.
- Button or keyboard key names are marked in this font.

### Warning, Caution, and Note

This manual shows warnings, cautions, and notes with the following figures:

**Warning!**

This indicates that you need to follow this message for your safety and to prevent the product from damage.

---

**Caution!**

This indicates that you need to follow this message to prevent data from being lost or corrupted.

---

**Note:**

This indicates that this message provides additional information.

---

## Definition of Terms

For clarity, this manual defines some terms as follows:

Term	Definition
Preface	The introductory part preceding the Table of Contents in this manual
Vieworks Imaging Solution	Indicates the control software provided with the product together by Vieworks
VIS	Vieworks Imaging Solution

## Revision History

This document has the revision history as follows:

Version	Date	Description
1.0	2019-06-24	Initial Release
1.1	2020-03-06	<ul style="list-style-type: none"><li>• Applied new CI</li><li>• Specified the type of Camera Link connectors</li></ul>
1.2	2020-11-06	<ul style="list-style-type: none"><li>• Added the Binning feature</li><li>• Added the manual setting of the Flat Field Target Level</li></ul> <p>* All added features are only available with serial commands.</p>
1.3	2021-07-09	Software trigger command change (gst -> nst)
	2022-05-27	Revised the mechanical dimension
1.4	2022-12-01	Revised the document template

## Contents

<b>Chapter 1. Precautions .....</b>	<b>15</b>
<b>Chapter 2. Warranty .....</b>	<b>16</b>
<b>Chapter 3. Compliance &amp; Certifications .....</b>	<b>17</b>
3.1    FCC Compliance .....	17
3.2    CE: DoC.....	17
3.3    KC .....	17
<b>Chapter 4. Package Component.....</b>	<b>18</b>
<b>Chapter 5. Product Specifications.....</b>	<b>19</b>
5.1    Overview .....	19
5.2    Specifications .....	20
5.3    Camera Block Diagram .....	21
5.4    Spectral Response .....	22
5.4.1    Monochrome Spectral Response .....	22
5.4.2    Color Spectral Response.....	24
5.5    Mechanical Specification .....	26
<b>Chapter 6. Connecting the Camera.....</b>	<b>27</b>
6.1    Precaution to Center the Image Sensor .....	28
6.2    Precaution about Blurring Compared to the Center.....	28
6.3    Controlling the Camera .....	28
<b>Chapter 7. Camera Interface.....</b>	<b>29</b>
7.1    General Description.....	29
7.2    Camera Link SDR Connector.....	31
7.3    Power Input Receptacle.....	34
7.4    Control I/O Receptacle .....	35
7.5    Trigger Input Circuit.....	36
7.6    Strobe Output Circuit .....	36
<b>Chapter 8. Acquisition Control.....</b>	<b>37</b>
8.1    Overview .....	37

8.2	Acquisition Start/Stop Commands and Acquisition Mode.....	40
8.3	Exposure Start Trigger .....	41
8.3.1	Trigger Mode .....	41
8.3.2	Using a Software Trigger Signal.....	44
8.3.3	Using a CC1 Trigger Signal.....	45
8.3.4	Using an External Trigger Signal .....	46
8.3.5	Exposure Mode .....	48
8.4	Setting the Exposure Time .....	50
8.5	Rolling Shutter.....	51
8.6	Overlapping Exposure with Sensor Readout .....	53
8.6.1	Overlapped Acquisition with Trigger Mode = Off .....	53
8.6.2	Overlapped Acquisition with Trigger Mode = On.....	54
8.7	Maximum Allowed Frame Rate.....	56
8.7.1	Increasing the Maximum Allowed Frame Rate .....	57
<b>Chapter 9. Camera Features.....</b>		<b>58</b>
9.1	Image Region of Interest.....	58
9.2	Binning (Monochrome Only) .....	61
9.3	Pixel Format.....	63
9.4	Camera Link Tap Geometry .....	64
9.5	Camera Link Pixel Clock Speed .....	65
9.6	AWB ROI (Color Camera) .....	66
9.7	White Balance (Color Only).....	67
9.7.1	Auto White Balance .....	67
9.8	Gain and Black Level .....	68
9.9	Hot Pixel Correction .....	69
9.10	Dynamic Defective Pixel Correction .....	69
9.11	Defective Pixel Correction .....	71
9.11.1	Correction Method.....	71
9.12	Flat Field Correction.....	72

9.12.1	Sequence of Flat Field Correction .....	73
9.12.2	Flat Field Data Selector .....	77
9.13	Digital I/O Control .....	79
9.14	Timer Control .....	83
9.15	TEC Control .....	84
9.16	Temperature Monitor.....	85
9.17	Status LED .....	85
9.18	Test Image.....	86
9.19	Reverse X.....	88
9.20	Device Reset .....	89
9.21	Field Upgrade.....	89
<b>Chapter 10. Camera Configuration .....</b>		<b>90</b>
10.1	Setup Command .....	90
10.2	Actual Runtime of Commands .....	92
10.3	User Set Control.....	93
10.4	Sequencer Control .....	95
10.5	Command List .....	97
<b>Chapter 11. Configurator GUI .....</b>		<b>104</b>
11.1	Camera Scan .....	104
11.2	Menu .....	105
11.2.1	File .....	105
11.2.2	Start-Up .....	106
11.2.3	Tool.....	107
11.2.4	Acquisition .....	108
11.2.5	About .....	109
11.3	Tab .....	110
11.3.1	VIEW Tab.....	110
11.3.2	MODE/EXP Tab.....	111
11.3.3	ANALOG Tab.....	112

11.3.4 FFC Tab .....	113
11.3.5 Digital I/O Tab .....	114
11.3.6 TEC Tab .....	115
11.3.7 AWB Tab (Color Camera Only) .....	116
<b>Chapter 12. Troubleshooting .....</b>	<b>117</b>
<b>Appendix A. Defective Pixel Map Download .....</b>	<b>119</b>
<b>Appendix B. Field Upgrade.....</b>	<b>123</b>
<b>Appendix C. Index .....</b>	<b>127</b>



## Tables

Table 5-1	Specifications of VP-101MC/151MC .....	20
Table 7-1	Pin Assignments for Camera Link Connector 1 .....	31
Table 7-2	Pin Assignments for Camera Link Connector 2.....	32
Table 7-3	Connector Arrangement for the Camera Link Tap Geometry .....	33
Table 7-4	Pin Configurations for Power Input Receptacle .....	34
Table 7-5	Pin Configurations for Control I/O Receptacle.....	35
Table 8-1	Minimum and Maximum Exposure Time Setting .....	50
Table 8-2	Temporal Offset Values depending on VP-101MC's Camera Link Tap Geometry....	52
Table 8-3	Temporal Offset Values depending on VP-151MC's Camera Link Tap Geometry....	52
Table 8-4	Max. Allowed Exposure Time for Overlapped Operation of VP-101MC.....	54
Table 8-5	Max. Allowed Exposure Time for Overlapped Operation of VP-151MC.....	55
Table 9-1	Commands related to ROI.....	58
Table 9-2	Minimum ROI Offset X, Offset Y, Width and Height Settings.....	60
Table 9-3	Maximum Frame Rates by VP-101MC Vertical ROI Changes (@ Pixel Clock 85MHz) ...	60
Table 9-4	Maximum Frame Rates by VP-151MC Vertical ROI Changes (@ Pixel Clock 85MHz) ...	60
Table 9-5	Commands related to Binning .....	61
Table 9-6	Command related to Pixel Format .....	63
Table 9-7	Command related to Camera Link Tap Geometry .....	64
Table 9-8	Command related to Camera Link Pixel Clock Speed .....	65
Table 9-9	Commands related to AWB ROI.....	66
Table 9-10	Command related to White Balance .....	67
Table 9-11	Command related to Auto White Balance .....	67
Table 9-12	Commands related to Gain and Black Level.....	68
Table 9-13	Command related to Hot Pixel Correction .....	69

Table 9-14	Commands related to Dynamic Defective Pixel Correction.....	69
Table 9-15	Calculation of Defect Pixel Correction Value .....	71
Table 9-16	Commands related to Flat Field Correction .....	72
Table 9-17	Commands related to Digital I/O Control.....	79
Table 9-18	Command related to Debounce Time .....	82
Table 9-19	Commands related to Timer Control .....	83
Table 9-20	Commands related to TEC Control.....	84
Table 9-21	Command related to Device Temperature .....	85
Table 9-22	Status LED .....	85
Table 9-23	Commands related to Test Image .....	86
Table 9-24	Command related to Reverse X.....	88
Table 9-25	Command related to Device Reset .....	89
Table 10-1	Commands related to User Set Control.....	93
Table 10-2	Commands related to Sequencer Control.....	95
Table 10-3	Command List #1 .....	97
Table 10-4	Command List #2 .....	98
Table 10-5	Command List #3 .....	99
Table 10-6	Command List #4 .....	100
Table 10-7	Command List #5 .....	101
Table 10-8	Command List #6 .....	102
Table 10-9	Command List #7 .....	103

## Figures

Figure 5-1	Camera Block Diagram.....	21
Figure 5-2	VP-101MC-M8 Spectral Response .....	22
Figure 5-3	VP-151MC-M5 Spectral Response .....	23
Figure 5-4	VP-101MC-C8 Spectral Response .....	24
Figure 5-5	VP-151MC-C5 Spectral Response .....	25
Figure 5-6	Mechanical Dimension for VP-101MC-8 M72-mount .....	26
Figure 5-7	Mechanical Dimension for VP-151MC-5 M72-mount .....	26
Figure 7-1	VP-101MC Back Panel .....	29
Figure 7-2	VP-151MC Back Panel .....	30
Figure 7-3	Camera Link Connector.....	31
Figure 7-4	Pin Assignments for Power Input Receptacle .....	34
Figure 7-5	Pin Assignments for Control I/O Receptacle.....	35
Figure 7-6	Trigger Input Schematic.....	36
Figure 7-7	Strobe Output Schematic .....	36
Figure 8-1	Exposure Start Triggering.....	38
Figure 8-2	Frame Acquisition with Software Trigger Signal .....	44
Figure 8-3	External Trigger Delay .....	47
Figure 8-4	Timed Exposure Mode .....	48
Figure 8-5	Trigger Overlapped with Timed Exposure Mode .....	48
Figure 8-6	Trigger Width Exposure Mode .....	49
Figure 8-7	Rolling Shutter Operation.....	51
Figure 8-8	Overlapped Exposure and Readout .....	53
Figure 8-9	Non-overlapped Exposure and Sensor Readout.....	55
Figure 9-1	Region of Interest.....	59

Figure 9-2	2 × 2 Binning .....	62
Figure 9-3	Camera Link Tap Geometry.....	64
Figure 9-4	Effective Data ROI.....	66
Figure 9-5	Dynamic Defective Pixel Correction.....	70
Figure 9-6	Location of Defect Pixel to be corrected .....	71
Figure 9-7	Flat Field Correction in Configurator .....	74
Figure 9-8	Generation and Application of Flat Field Data.....	76
Figure 9-9	Bilinear Interpolated Magnification.....	76
Figure 9-10	Flat Field Data Selector.....	77
Figure 9-11	User Output .....	79
Figure 9-12	Exposure Active Signal.....	80
Figure 9-13	Strobe Signal .....	81
Figure 9-14	Debounce .....	82
Figure 9-15	Timer Signal.....	84
Figure 9-16	Test Image1 .....	86
Figure 9-17	Test Image2 .....	87
Figure 9-18	Test Image3 .....	87
Figure 9-19	Original Image .....	88
Figure 9-20	Reverse X Image.....	88
Figure 10-1	Actual Runtime of Commands.....	92
Figure 10-2	User Set Control.....	94
Figure 10-3	Sequencer Diagram (Use Case).....	96
Figure 11-1	Configurator Loading Window .....	104
Figure 11-2	File Menu .....	105
Figure 11-3	Start-Up Menu .....	106
Figure 11-4	Tool Menu .....	107

Figure 11-5 Acquisition Menu .....108

Figure 11-6 About Menu .....109

Figure 11-7 VIEW Tab.....110

Figure 11-8 MODE/EXP Tab.....111

Figure 11-9 ANALOG Tab.....112

Figure 11-10 FFC Tab .....113

Figure 11-11 Digital I/O Tab .....114

Figure 11-12 TEC Tab .....115

Figure 11-13 AWB Tab (Color Camera Only) .....116



## Chapter 1. Precautions

### General



- Do not drop, disassemble, repair or alter the device. Doing so may damage the camera electronics and cause an electric shock.
- Do not let children or companion animals touch the device without supervision.
- Stop using the device and contact the nearest dealer or manufacturer for technical assistance if liquid such as water, drinks or chemicals gets into the device.
- Do not touch the device with wet hands. Doing so may cause an electric shock.
- Make sure that the temperature of the camera does not exceed the temperature range specified in 5.2 Specifications. Otherwise the device may be damaged by extreme temperature.

### Installation and Maintenance



- Do not install in dusty or dirty areas - or near an air conditioner or heater to reduce the risk of damage to the device.
- Avoid installing and operating in an extreme environment where vibration, heat, humidity, dust, strong magnetic fields, explosive/corrosive mists or gases are present.
- Do not apply excessive vibration and shock to the device. This may damage the device.
- Avoid direct exposure to a high intensity light source. This may damage the image sensor.
- Do not install the device under unstable lighting conditions. Severe lighting change will affect the quality of the image produced by the device.

### Power Supply



- Applying incorrect power can damage the camera. If the voltage applied to the camera is greater or less than the camera's nominal voltage, the camera may be damaged or operate erratically. Please refer to 5.2 Specifications for the camera's nominal voltage.
  - ※ Vieworks Co., Ltd. does NOT provide power supplies with the device.
- Make sure the power is turned off before connecting the power cord to the camera. Otherwise damage to the camera may result.

## Chapter 2. Warranty

Do not open the housing of the camera. The warranty becomes void if the housing is opened. For information about the warranty, please contact your local dealer or factory representative.



## Chapter 3. Compliance & Certifications

### 3.1 FCC Compliance

This equipment has been tested and found to comply with the limits for a Class A digital device, pursuant to part 15 of the FCC Rules. These limits are designed to provide reasonable protection against harmful interference when the equipment is operated in a commercial environment. This equipment generates, uses, and can radiate radio frequency energy and, if not installed and used in accordance with the instruction manual, may cause harmful interference to radio communications. Operation of this equipment in a residential area is likely to cause harmful interference in which case the user will be required to correct the interference at his own expenses.

### 3.2 CE: DoC

EMC Directive 2014/30/EU  
EN 55032:2012 (Class A), EN 55024:2010  
Class A

### 3.3 KC

#### KCC Statement

Type	Description
Class A (Broadcasting Communication Device for Office Use)	This device obtained EMC registration for office use (Class A), and may be used in places other than home. Sellers and/or users need to take note of this.

## Chapter 4. Package Component

---

Package Component



VP-101MC <M72-mount>



VP-151MC <M72-mount>

---

## Chapter 5. Product Specifications

### 5.1 Overview

The VP-101MC/151MC, the latest models of the industrial proven VP series, are new 101 and 151 megapixel resolution CMOS cameras with the Camera Link interface. The VP-101MC/151MC cameras are based on the latest CMOS image sensor technology (IMX461 and IMX411) from Sony Semiconductor Solutions Corporation, and offer up to 8.1 frames per second at 11648 × 8742 and up to 5.5 frames per second at 14192 × 10640 resolution respectively. These cameras use thermo-electric Peltier (TEC) cooling technology developed for and used by many demanding medical market customers. The TEC maintains the operating temperature of the CMOS image sensor at up to 15 degrees below ambient temperature. These cameras provide a stable operating condition and the ability to expose for a long period of time to increase camera sensitivity. Featured with the stable operating capability and high resolution, these cameras are ideal for demanding applications such as FPD, PCB and semiconductor inspections.

#### Main Features

- High Speed 101 / 151 Megapixel CMOS Image Sensor
- Thermoelectric Peltier Cooling – about 15 degrees below ambient temperature
- Minimizing the number of hot pixels with TEC
- Electronic Exposure Time Control (Rolling Shutter)
- Output Pixel Format: 8 / 10 / 12 bit
- Strobe Output
- Dynamic Defective Pixel Correction
- Camera Link Base / Medium / Full / 10 Tap
- Camera Link Tap Geometry: 2 Tap, 4 Tap, 8 Tap, 10 Tap
- Camera Link Clock Frequency Selector
- Gain / Black Level Control
- Test Image
- LVDS (RS-644) Serial Communication by Camera Link Interface
- Temperature Monitor
- Field Upgrade
- DSNU and PRNU Correction
- Flat Field Correction with Sequencer Control
- Hot Pixel Correction
- GenICam Compatible – XML based Control

## 5.2 Specifications

The technical specifications of the VP-101MC/151MC cameras are as follows.

Specifications	VP-101MC-M/C 8 H	VP-151MC-M/C 5 H
Active Image (H × V)	11648 × 8742	14192 × 10640
Sensor	Sony IMX461	Sony IMX411
Sensor Type	Back-Illuminated CMOS Image Sensor	
Sensor Size (Diagonal)	43.80 mm × 32.87 mm (55 mm)	53.36 mm × 40.01 mm (66.7 mm)
Pixel size	3.76 μm × 3.76 μm	
Interface	Camera Link Base / Medium / Full / 10 Tap	
Electronic Shutter	Rolling Shutter	
Max. Frame Rate (Overlapped)	2 Tap: 1.6 fps	2 Tap: 1.1 fps
	4 Tap: 3.2 fps	4 Tap: 2.2 fps
	8 Tap: 6.5 fps	8 Tap: 4.4 fps
	10 Tap: 8.1 fps	10 Tap: 5.5 fps
Pixel Data Format	8 bit / 10 bit / 12 bit	
Camera Link Pixel Clock	65 MHz / 85 MHz	
Exposure Time	1 μs ~ 60 s (1 μs step)	
Partial Scan (Max. Speed)	635 fps at 2 Lines	488 fps at 2 Lines
Binning	Sensor	×1, ×3 (Horizontal and Vertical Dependent)
	Logic	×1, ×2, ×4 (Horizontal and Vertical Independent)
Black Level Control	0 ~ 255 LSB at 12 bit	
Gain Control	1× ~ 32×	
Trigger Synchronization	Overlapped	Free-Run
	Non-overlapped	Hardware Trigger, Software Trigger, CC1 or User Output0
External Trigger	3.3 V ~ 24.0 V Logical level input, Optically isolated	
Software Trigger	Asynchronous, Programmable via Camera API	
Dynamic Range	78 dB	
Lens Mount	M72-mount	
Cooling Method	Thermoelectric Peltier Cooling	
Cooling Performance	15°C below ambient temperature / Standard cooling with a fan	
Power	External	11 ~ 24 V DC
	Dissipation	Typ. 26.0 W
Environmental	Operating: 0 ~ 40°C, Storage: -40°C ~ 70°C	
Dimension / Weight	100mm × 100mm × 88mm, 1.1kg (with M72-mount)	110mm × 110mm × 88mm, 1.3kg (with M72-mount)
Configuration SW	Configurator / Vieworks Imaging Solution 7.X	

Table 5-1 Specifications of VP-101MC/151MC

### 5.3 Camera Block Diagram

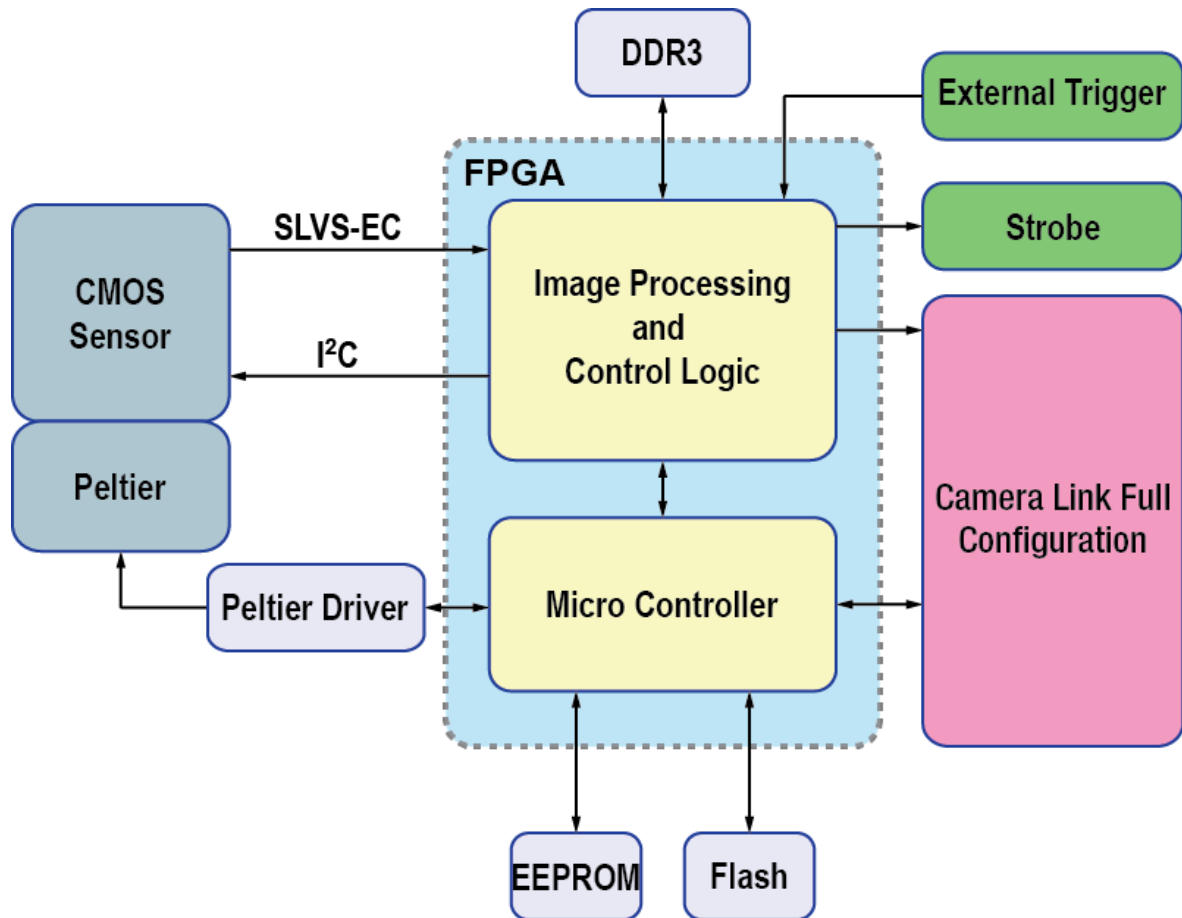

Figure 5-1 Camera Block Diagram

All controls and data processing of the VP-101MC/151MC cameras are carried out in one FPGA chip. The FPGA generally consists of a 32-bit RISC Micro-Controller and Processing & Control logic. The Micro-Controller receives commands from the user through the Camera Link interface and then processes them. The Processing & Control logic processes the image data received from the CMOS image sensor and then transmits data through the Camera Link interface. The Processing & Control logic also controls the trigger inputs and strobe outputs, which are sensitive to time. Furthermore, Flash and DDR3 are installed outside FPGA. The DDR3 is used for the frame buffer to process images and the Flash stores the firmware to operate the Micro-Controller. A Peltier Driver is applied to control a Thermoelectric Peltier Cooling unit.

## 5.4 Spectral Response

### 5.4.1 Monochrome Spectral Response

The following graph shows the spectral response of the VP-101MC monochrome camera.

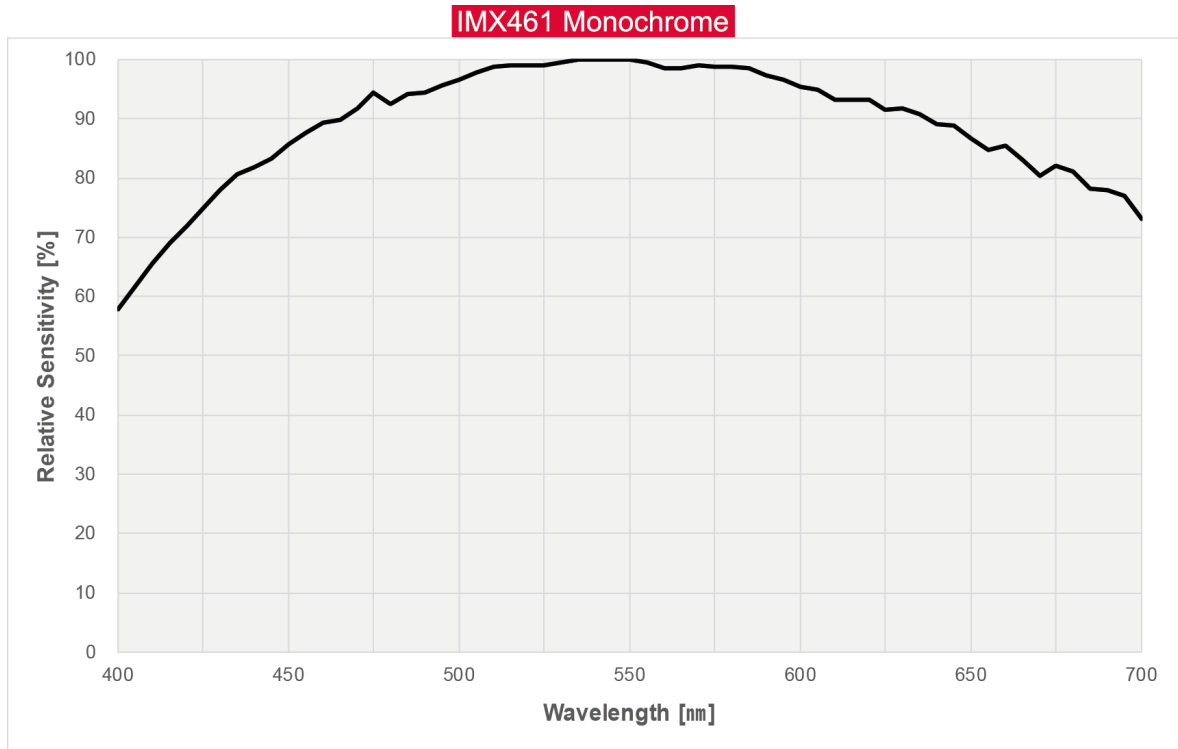

Figure 5-2 VP-101MC-M8 Spectral Response

The following graph shows the spectral response of the VP-151MC monochrome camera.

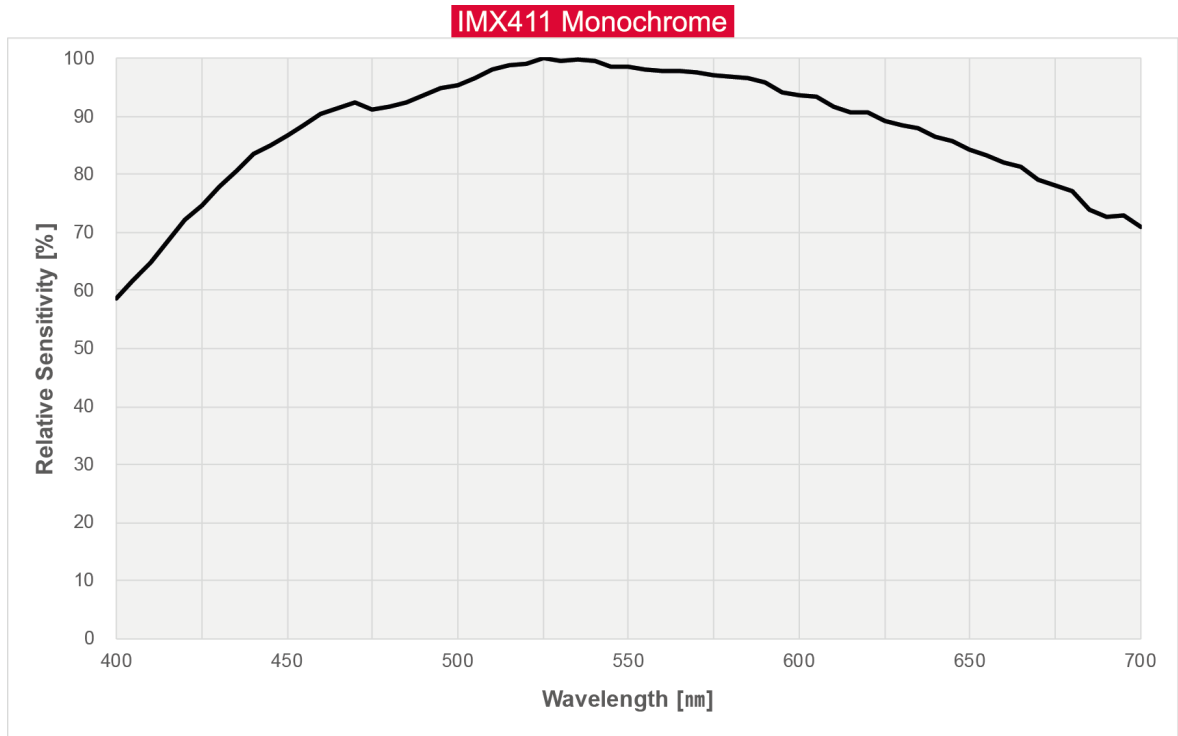

Figure 5-3 VP-151MC-M5 Spectral Response

### 5.4.2 Color Spectral Response

The following graph shows the spectral response of the VP-101MC color camera.

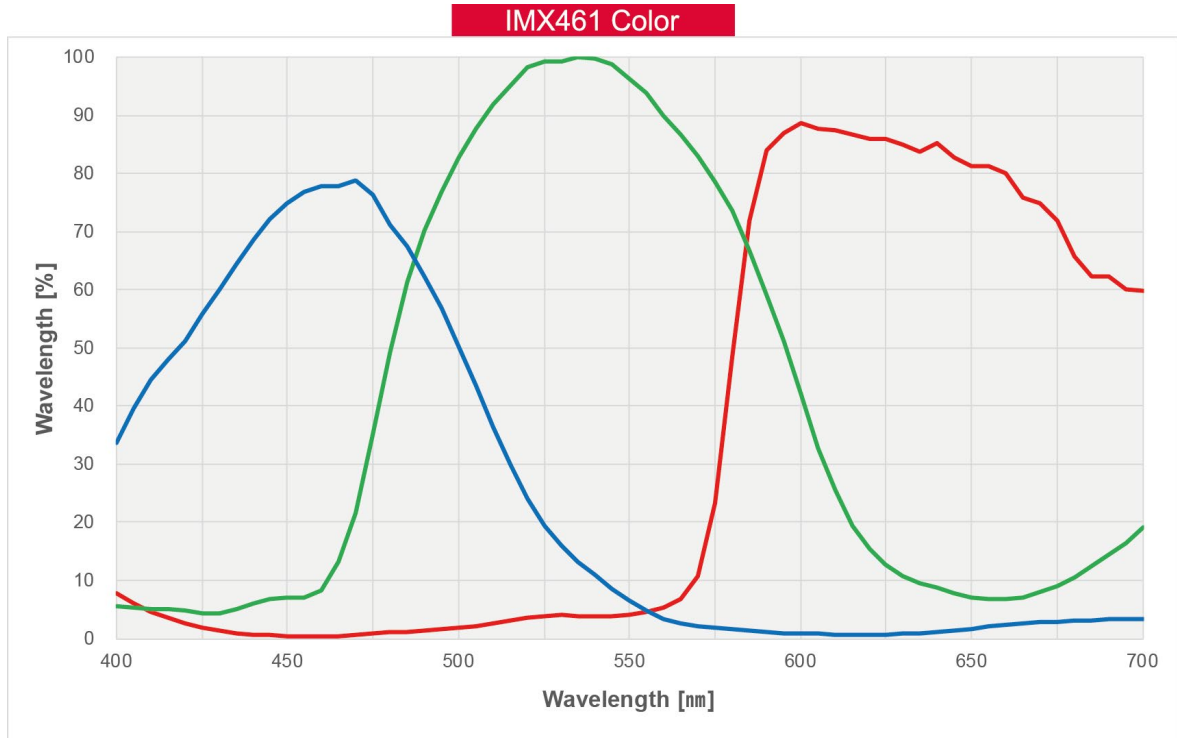

Figure 5-4 VP-101MC-C8 Spectral Response



The following graph shows the spectral response of the VP-151MC color camera.

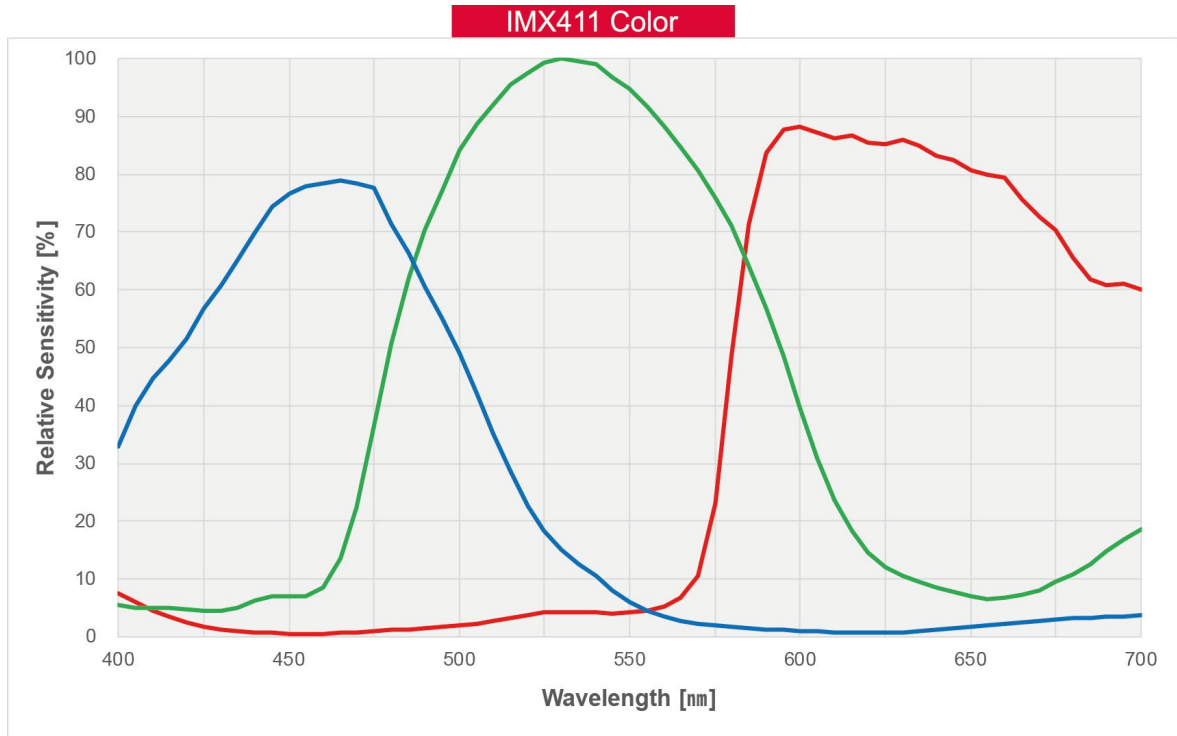

Figure 5-5 VP-151MC-C5 Spectral Response

### 5.5 Mechanical Specification

The camera dimensions in millimeters are shown in the following figures.

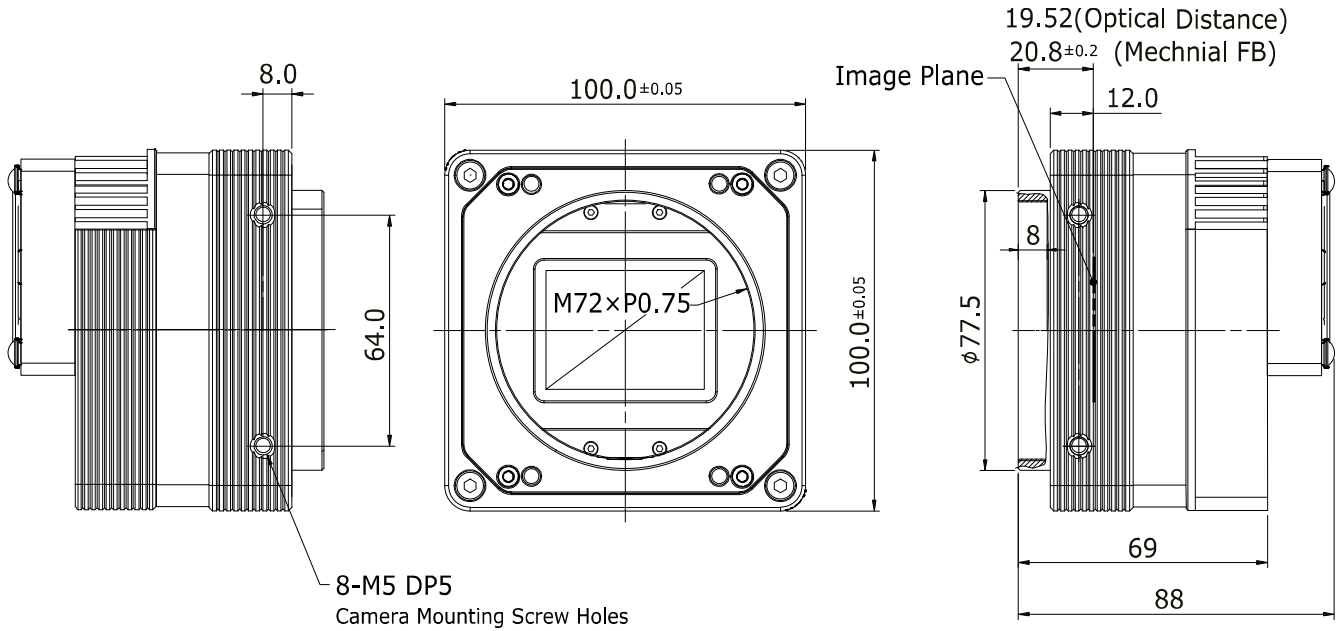

Figure 5-6 Mechanical Dimension for VP-101MC-8 M72-mount

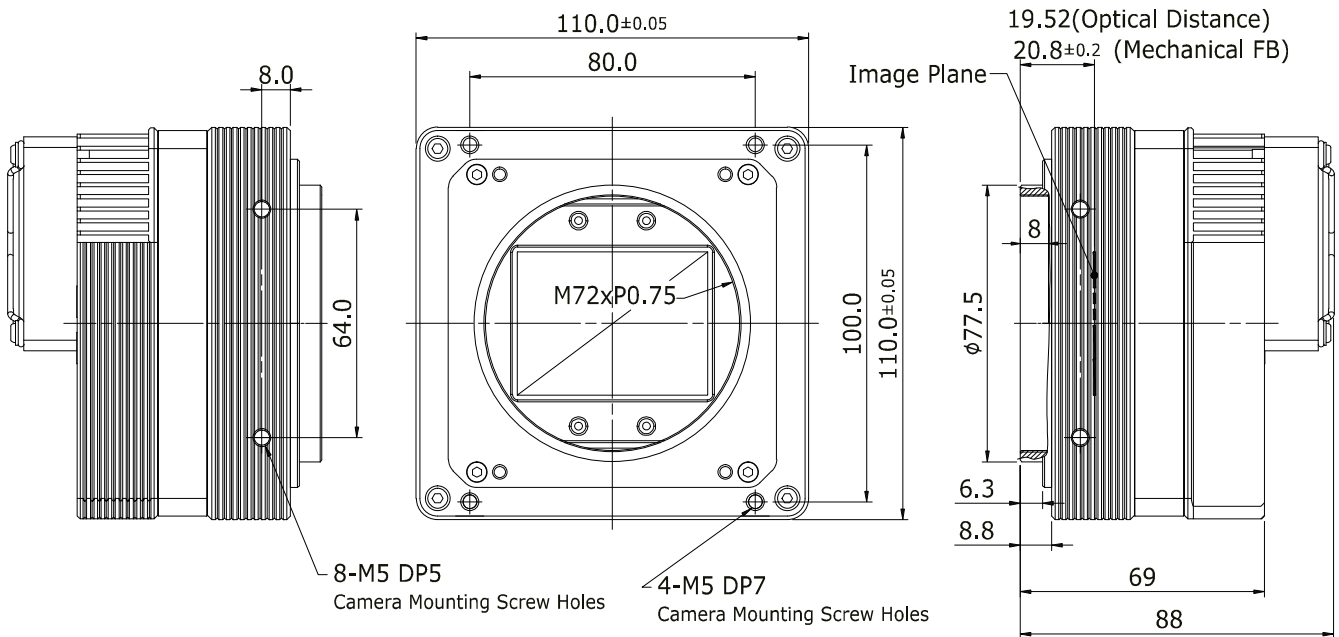

Figure 5-7 Mechanical Dimension for VP-151MC-5 M72-mount

## Chapter 6. Connecting the Camera

The following instructions assume that you have installed a Camera Link Frame Grabber in your computer including related software. For more detailed information, refer to your Camera Link Frame Grabber User Manual.

To connect the camera to your computer, follow the steps below:

1. Make sure that the power supply is not connected to the camera and your computer is turned off.
2. Plug one end of a coax cable into the Camera Link1 connector on the camera and the other end of the coax cable into the Base connector of the Camera Link Frame Grabber in your computer. Plug one end of the other Camera Link cable into the Camera Link2 connector on the camera and the other end of the Camera Link cable into the Medium/Full connector on the Camera Link frame grabber.
3. Connect the plug of the power adapter to the 6-pin power input receptacle on the camera.
4. Plug the power adapter into a working electrical outlet.
5. Verify all the cable connections are secure.

### Precautions for using Camera Link Medium / Full / 10 Tap Configuration



#### Caution!

The VP-101MC/151MC cameras support the Camera Link Base / Medium / Full / 10 Tap configuration. To operate the camera in the medium, full or 10 tap configuration, you must connect the camera to the Camera Link frame grabber using two Camera Link cables. Make sure that you connect both Camera Link1 (Base) and Camera Link2 (Medium/Full) connectors on the camera to their respective connectors on the Camera Link frame grabber.

---

## 6.1 Precaution to Center the Image Sensor

- Users do not need to center the image sensor as it is adjusted as factory default settings.
- When you need to adjust the center of the image sensor, please contact your local dealer or the manufacturer for technical assistance.

## 6.2 Precaution about Blurring Compared to the Center

- Users do not need to adjust the tilt as it is adjusted as factory default settings.
- If the tilt settings need to be adjusted inevitably, please contact your local dealer or factory representative for technical support.

## 6.3 Controlling the Camera

- You can control the camera by using the Configurator.
- You can download the latest Configurator at <http://vision.vieworks.com>.
- Please refer to your Camera Link frame grabber user manual.

## Chapter 7. Camera Interface

### 7.1 General Description

As shown in the following figure, four types of connectors and an LED indicator are located on the back of the camera and have the functions as follows:

- ① Status LED: displays power status and operation mode.
- ② 6 pin Power Input Receptacle: supplies power to the camera.
- ③ 4 pin Control I/O Receptacle: inputs external trigger signals and outputs strobe signals.
- ④ 26 pin SDR Connector 1 (Camera Link Base): transmits video data and controls the camera.
- ⑤ 26 pin SDR Connector 2 (Camera Link Medium/Full): transmits video data.

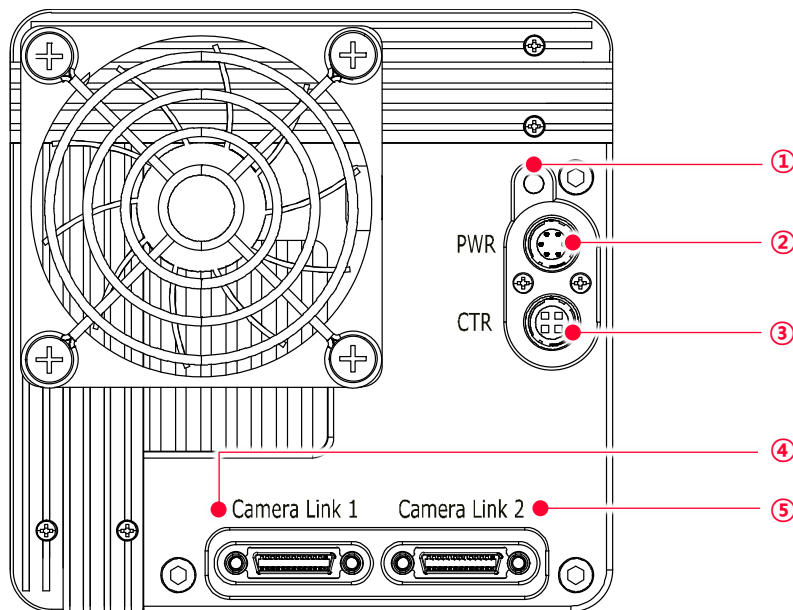

Figure 7-1 VP-101MC Back Panel

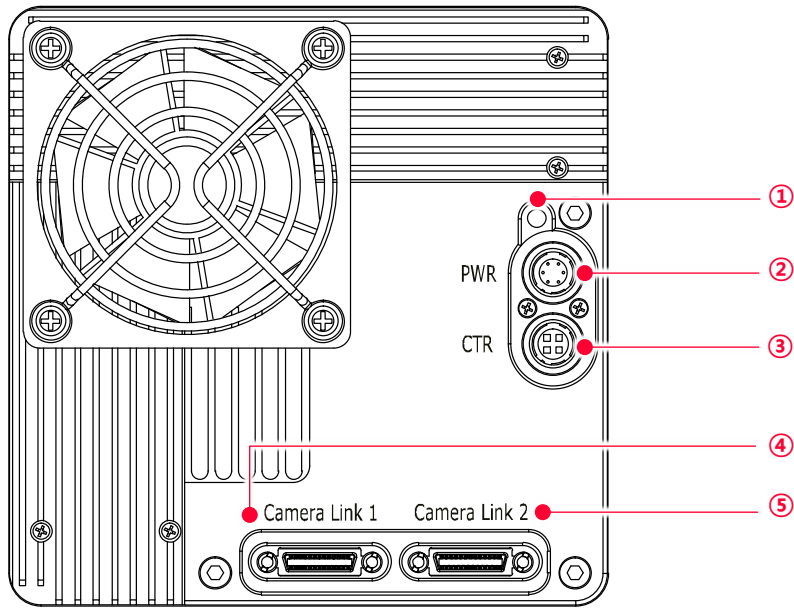

Figure 7-2 VP-151MC Back Panel

## 7.2 Camera Link SDR Connector

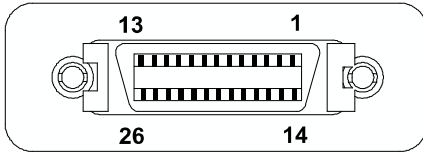

Figure 7-3 Camera Link Connector

The Camera Link connectors on the camera comply with the Camera Link standard and the following lists show the pin assignments of the connectors.

PAIR List	Pin	Signal Name	Type	Description
PAIR 0	1	Ground	Ground	Cable Shield
	14	Ground	Ground	Cable Shield
PAIR 1	2	-X0	LVDS - Out	Camera Link Transmitter
	15	+X0	LVDS - Out	Camera Link Transmitter
PAIR 2	3	-X1	LVDS - Out	Camera Link Transmitter
	16	+X1	LVDS - Out	Camera Link Transmitter
PAIR 3	4	-X2	LVDS - Out	Camera Link Transmitter
	17	+X2	LVDS - Out	Camera Link Transmitter
PAIR 4	5	-XCLK	LVDS - Out	Camera Link Transmitter
	18	+XCLK	LVDS - Out	Camera Link Transmitter
PAIR 5	6	-X3	LVDS - Out	Camera Link Transmitter
	19	+X3	LVDS - Out	Camera Link Transmitter
PAIR 6	7	+ SerTC	LVDS - In	Serial Data Receiver
	20	- SerTC	LVDS - In	Serial Data Receiver
PAIR 7	8	- SerTFG	LVDS - Out	Serial Data Transmitter
	21	+ SerTFG	LVDS - Out	Serial Data Transmitter
PAIR 8	9	- CC 1	LVDS - In	Software External Trigger
	22	+ CC 1	LVDS - In	Software External Trigger
PAIR 9	10	N/C	N/C	N/C
	23	N/C	N/C	N/C
PAIR 10	11	N/C	N/C	N/C
	24	N/C	N/C	N/C
PAIR 11	12	N/C	N/C	N/C
	25	N/C	N/C	N/C
PAIR 12	13	Ground	Ground	Cable Shield
	26	Ground	Ground	Cable Shield

Table 7-1 Pin Assignments for Camera Link Connector 1

PAIR List	Pin	Signal Name	Type	Description
PAIR 0	1	Ground	Ground	Cable Shield
	14	Ground	Ground	Cable Shield
PAIR 1	2	-Y0	LVDS - Out	Camera Link Transmitter
	15	+Y0	LVDS - Out	Camera Link Transmitter
PAIR 2	3	-Y1	LVDS - Out	Camera Link Transmitter
	16	+Y1	LVDS - Out	Camera Link Transmitter
PAIR 3	4	-Y2	LVDS - Out	Camera Link Transmitter
	17	+Y2	LVDS - Out	Camera Link Transmitter
PAIR 4	5	-YCLK	LVDS - Out	Camera Link Transmitter
	18	+YCLK	LVDS - Out	Camera Link Clock Tx
PAIR 5	6	-Y3	LVDS - Out	Camera Link Channel Tx
	19	+Y3	LVDS - Out	Camera Link Channel Tx
PAIR 6	7	-	Not Used	Connected with 100 ohm
	20	-	Not Used	
PAIR 7	8	-Z0	LVDS - Out	Camera Link Transmitter
	21	+Z0	LVDS - Out	Camera Link Transmitter
PAIR 8	9	-Z1	LVDS - Out	Camera Link Transmitter
	22	+Z1	LVDS - Out	Camera Link Transmitter
PAIR 9	10	-Z2	LVDS - Out	Camera Link Transmitter
	23	+Z2	LVDS - Out	Camera Link Transmitter
PAIR 10	11	-ZCLK	LVDS - Out	Camera Link Transmitter
	24	+ZCLK	LVDS - Out	Camera Link Clock Tx
PAIR 11	12	-Z3	LVDS - Out	Camera Link Channel Tx
	25	+Z3	LVDS - Out	Camera Link Channel Tx
PAIR 12	13	Ground	Ground	Cable Shield
	26	Ground	Ground	Cable Shield

Table 7-2 Pin Assignments for Camera Link Connector 2



Model	Camera Link Tap Geometry	CL Configuration	CL Connector 1	CL Connector 2
VP-101MC	2 Tap	BASE	○	X
VP-151MC	4 Tap	MEDIUM	○	○
	8 Tap	FULL	○	○
	10 Tap	10 Tap	○	○

Table 7-3 Connector Arrangement for the Camera Link Tap Geometry



**Caution!**

When you connect a Camera Link frame grabber to the Camera Link connectors on the camera using Camera Link cables, make sure you connect the cables to their correct connectors. If you connect the Camera Link connector 1 on the camera to a connector other than connector 1 of the Camera Link frame grabber, the camera may not transmit images correctly or the serial communication between the camera and the computer may fail.

### 7.3 Power Input Receptacle

The power input receptacle is a Hirose 6 pin connector (part # HR10A-7R-6PB). The pin assignments and configurations are as follows:

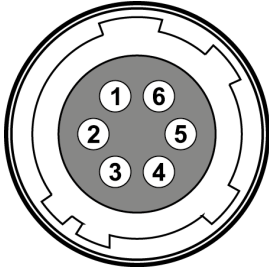

Figure 7-4 Pin Assignments for Power Input Receptacle

Pin Number	Signal	Type	Description
1, 2, 3	+12V DC	Input	DC Power Input
4, 5, 6	DC Ground	Input	DC Ground

Table 7-4 Pin Configurations for Power Input Receptacle



**Note:**

- A recommended mating connector for the Hirose 6 pin connector is the Hirose 6 pin plug (part # HR10A-7P-6S) or the equivalent.
- It is recommended that you use the power adapter, which has at least 5 A current output at 11 ~ 24 V voltage output (You need to purchase a power adapter separately.).

#### Precaution for Power Input



**Caution!**

- Make sure the power is turned off before connecting the power cord to the camera. Otherwise, damage to the camera may result.
- If the voltage applied to the camera is greater than specified in the specifications, damage to the camera may result.

## 7.4 Control I/O Receptacle

The Control I/O Receptacle is a Hirose 4 pin connector (part # HR10A-7R-4S) and consists of an external trigger signal input and strobe output ports. The pin assignments and configurations are as follows:

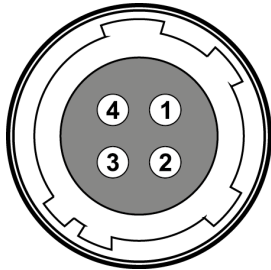

Figure 7-5 Pin Assignments for Control I/O Receptacle

Pin Number	Signal	Type	Description
1	Trigger Input +	Input	3.3 V ~ 24.0 V TTL input
2	Trigger Input -	Input	-
3	DC Ground	-	DC Ground
4	Line 1 Output	Output	3.3 V TTL Output Output resistance: 47 $\Omega$

Table 7-5 Pin Configurations for Control I/O Receptacle



**Note:**

A recommended mating connector for the Hirose 4-pin connector is the Hirose 4-pin plug (part # HR10A-7P-4P) or the equivalent.

### 7.5 Trigger Input Circuit

The following figure shows trigger signal input circuit of the 4 pin connector. Transmitted trigger signal is applied to the internal circuit through a photo coupler. With the Debounce feature, you can specify the width of input signal to be considered as a valid input signal. An external trigger circuit example is shown below.

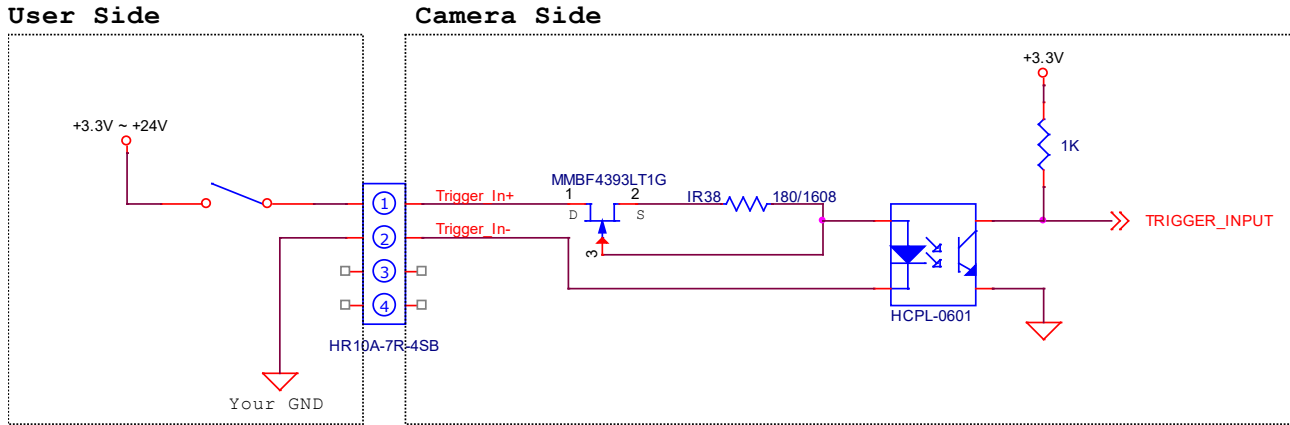

Figure 7-6 Trigger Input Schematic

### 7.6 Strobe Output Circuit

The strobe output signal comes out through a 3.3 V output level of TTL Driver IC. A pulse width of signal is synchronized with an exposure (shutter) signal of the camera.

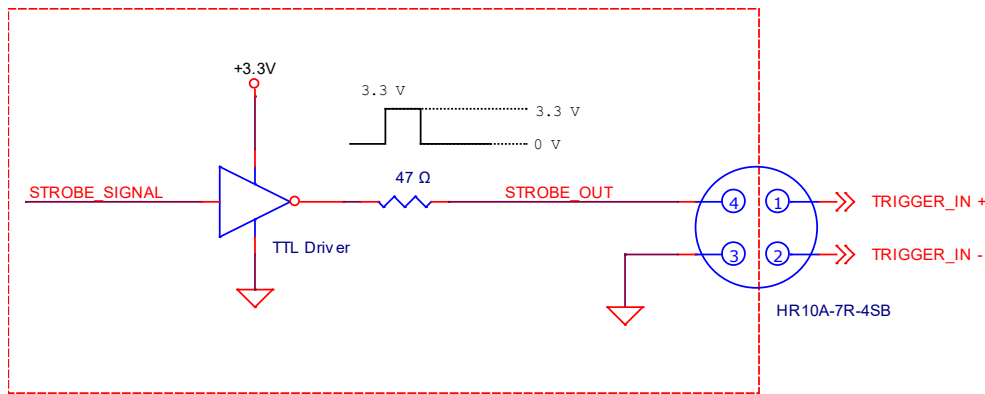

Figure 7-7 Strobe Output Schematic

## Chapter 8. Acquisition Control

This chapter provides detailed information about controlling image acquisition.

- Triggering image acquisition.
- Setting the exposure time
- Controlling the camera's image acquisition rate
- Variation of the camera's maximum allowed image acquisition rate according to the camera settings

### 8.1 Overview

This section presents an overview of the elements involved with controlling the acquisition of images.

Three major elements are involved in controlling the acquisition of images:

- Acquisition Start and Acquisition Stop commands and Acquisition Mode parameter
- Exposure start trigger
- Exposure time control



**Note:**

When reading the explanations in the overview and in this entire chapter, keep in mind that the term frame is typically used to mean a single acquired image.

---

#### Acquisition Start and Stop Commands and Acquisition Mode

The Acquisition Start ('ast') command prepares the camera to acquire frames. The camera cannot acquire frames unless an Acquisition Start command has first been executed.

A parameter called the Acquisition Mode has a direct bearing on how the Acquisition Start command operates. The VP-101MC/151MC cameras only support Continuous for the Acquisition Mode parameter. If the Acquisition Mode parameter is set to Continuous, an Acquisition Start command does not expire after a single frame is acquired. Once an Acquisition Start command has been executed, you can acquire as many frames as you like. The Acquisition Start command will remain in effect until you execute an Acquisition Stop ('asp') command. Once an Acquisition Stop command has been executed, the camera will not be able to acquire frames until a new Acquisition Start command is executed.

## Exposure Start Trigger

Applying an exposure start trigger signal to the camera will exit the camera from the *waiting for exposure start trigger* acquisition status and will begin the process of exposing and reading out a frame (see Figure 8-1).

As soon as the camera is ready to accept another exposure start trigger signal, it will return to the *waiting for exposure start trigger* acquisition status. A new exposure start trigger signal can then be applied to the camera to begin another frame exposure. The exposure start trigger has two modes: off and on.

If the **Trigger Mode** parameter is set to **Off** ('stm 0'), the camera will generate all required exposure start trigger signals internally, and you do not need to apply exposure start trigger signals to the camera. The rate at which the camera will generate the signals and acquire frames will be determined by the way that you set several frame rate related parameters.

If the **Trigger Mode** parameter is set to **On** ('stm 1'), you must trigger exposure start by applying exposure start trigger signals to the camera. Each time a trigger signal is applied, the camera will begin a frame exposure. When exposure start is being triggered in this manner, it is important that you do not attempt to trigger frames at a rate that is greater than the maximum allowed (There is a detailed explanation about the maximum allowed frame rate at the end of this chapter.). Exposure start trigger signals applied to the camera when it is not in a *waiting for exposure start trigger* acquisition status will be ignored.

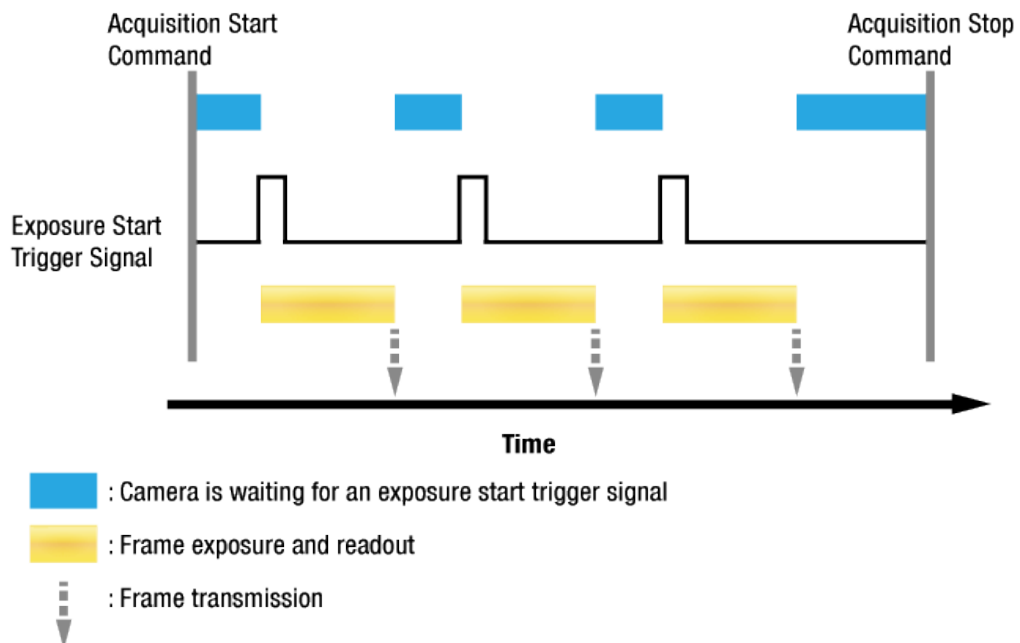

Figure 8-1 Exposure Start Triggering

## Applying Trigger Signals

The paragraphs above mention “applying a trigger signal”. There are four ways to apply an exposure start trigger signal to the camera: via **Software**, via **User Output0**, via **CC1** or via **Line0** (commonly referred to a hardware).

To apply trigger signals via **Software**, you must set the **Trigger Source** parameter to **Software** (‘sts 3’). At that point, each time a **Trigger Software** command is executed, the exposure start trigger signal will be applied to the camera.

To apply trigger signals via **User Output0**, you must set the **Trigger Source** parameter to **User Output0** (‘sts 10’). At that point, you can apply an exposure start trigger signal to the camera by switching the **User Output Value** parameter (‘suov 1/0’) between **On** (rise) and **Off** (fall).

To apply trigger signals via Camera Link Frame Grabber, you must set the **Trigger Source** parameter to **CC1** (‘sts 14’). At that point, each time a proper external trigger signal is applied to the camera by using the APIs provided by a Camera Link Frame Grabber manufacturer, the exposure start trigger signal will be applied to the camera. For more information, refer to your Camera Link Frame Grabber User Manual.

To apply trigger signals via hardware (external), you must set the **Trigger Source** parameter to **Line0** (‘sts 22’). At that point, each time a proper electrical signal is applied to the camera, an occurrence of the exposure start trigger signal will be recognized by the camera.

## Exposure Time Control

When an exposure start trigger signal is applied to the camera, the camera will begin to acquire a frame.

A critical aspect of frame acquisition is how long the pixels in the camera’s sensor will be exposed to light during the frame acquisition.

If the **Trigger Source** parameter is set to **Software**, the **Exposure Time** parameter will determine the exposure time for each frame.

If the **Trigger Source** parameter is set to **User Output0**, **CC1** or **Line0**, there are two modes of operation: **Timed** and **Trigger Width**.

With the **Timed** mode, the **Exposure Time** parameter will determine the exposure time for each frame.

With the **Trigger Width** mode, the way that you manipulate the rise and fall of the User Output, CC1 or hardware (external) signal will determine the exposure time. The **Trigger Width** mode is especially useful if you want to change the exposure time from frame to frame.

## 8.2 Acquisition Start/Stop Commands and Acquisition Mode

Executing an Acquisition Start ('ast') command prepares the camera to acquire frames. You must execute an Acquisition Start command before you can begin acquiring frames.

Executing an Acquisition Stop ('asp') command terminates the camera's ability to acquire frames.

When the camera receives an Acquisition Stop command:

- If the camera is not in the process of acquiring a frame, its ability to acquire frames will be terminated immediately.
- If the camera is in the process of acquiring a frame, the frame acquisition process will be allowed to finish and the camera's ability to acquire new frames will be terminated.



**Note:**

When you execute the Acquisition Start command while the previous frame acquisition process is still in progress, the command will be ignored. To avoid this, you must wait a minimum readout time (refer to Table 8-2 or Table 8-3) after the execution of the Acquisition Stop command. Then, you can safely execute the Acquisition Start command again.

---

The VP-101MC/151MC cameras only provides the Continuous mode of operation for the Acquisition Mode.

After an Acquisition Start command has been executed, exposure start can be triggered as desired. Each time an exposure start trigger is applied while the camera is in a *waiting for exposure start trigger* acquisition status, the camera will acquire and transmit a frame. The camera will retain the ability to acquire frames until an Acquisition Stop command is executed. Once the Acquisition Stop command is received, the camera will no longer be able to acquire frames.



## 8.3 Exposure Start Trigger

The Exposure Start trigger is used to begin frame acquisition. Exposure start trigger signals can be generated within the camera or may be applied externally by setting the **Trigger Source** parameter to **Software**, **User Output0**, **CC1** or **Line0**. If an exposure start trigger signal is applied to the camera, the camera will begin to expose a frame.

### 8.3.1 Trigger Mode

The main parameter associated with the exposure start trigger is the **Trigger Mode** parameter ('stm 0/1'). The **Trigger Mode** parameter for the exposure start trigger has two available settings: **Off** and **On**.

**Note:**

You cannot change the **Trigger Mode** parameter after executing the **Acquisition Start** command ('ast'). Change the **Trigger Mode** parameter after executing the **Acquisition Stop** command ('asp').

---

#### Trigger Mode = Off

When the **Trigger Mode** parameter('stm 0') is set to **Off**, the camera will generate all required exposure start trigger signals internally, and you do not need to apply exposure start trigger signals to the camera.

If the **Trigger Mode** parameter is set to **Off**, the camera will automatically begin generating exposure start trigger signals when it receives an **Acquisition Start** command. The camera will continue to generate exposure start trigger signals until it receives an **Acquisition Stop** command.

**Free-Run**

When you set the **Trigger Mode** parameter to **Off**, the camera will generate all required trigger signals internally. When the camera is set this way, it will constantly acquire images without any need for triggering by the user. This use case commonly referred as "free run".

---

The rate at which the exposure start trigger signals are generated may be determined by the camera's **Frame Rate** parameter('sfr n').

- If the parameter is set to a value less than the maximum allowed frame rate with the current camera settings, the camera will generate exposure start trigger signals at the rate specified by the parameter setting.
- If the parameter is set to a value greater than the maximum allowed frame rate with the current camera settings, the camera will generate exposure start trigger signals at the maximum allowed frame rate.

### Exposure Time Control with Trigger Mode = Off

When the **Trigger Mode** parameter is set to **Off**, the exposure time for each frame acquisition is determined by the value of the camera's **Exposure Time** parameter. For more information about the **Exposure Time** parameter('set n'), see [8.4 Setting the Exposure Time](#).

### Trigger Mode = On

When the **Trigger Mode** parameter is set to **On**('stm 1'), you must apply an exposure start trigger signal to the camera each time you want to begin a frame acquisition. The **Trigger Source** parameter('sts 3/10/14/22') specifies the source signal that will act as the exposure start trigger signal.

The available settings for the **Trigger Source** parameter are:

- **Software:** You can apply an exposure start trigger signal to the camera by executing a **Trigger Software** command('nst') for the exposure start trigger on your computer.
- **User Output0:** You can apply an exposure start trigger signal to the camera by switching the **User Output Value** parameter between **On** and **Off**('suov 1/0') on your computer.
- **CC1:** You can apply an exposure start trigger signal via **CC1** of the **Camera Link Frame Grabber**. For more information, refer to your **Camera Link Frame Grabber User Manual**.
- **Line0:** You can apply an exposure start trigger signal to the camera by injecting an externally generated electrical signal (commonly referred to as a hardware or external trigger signal) into the **Control I/O** receptacle on the camera. Refer to [7.5 Trigger Input Circuit](#) for more information.
- **Timer0Active:** You can apply an exposure start trigger signal to the camera using a user defined **Timer** signal. When you set the **Timer Trigger Source** parameter to **Line0**('stts 22') in the **Digital I/O** category, you can specify a delay for the **Line0** signal by using the **Timer Delay** parameter('stdl n'). For more information, refer to [9.14 Timer Control](#).

You must also set the **Trigger Activation** parameter after setting the **Trigger Source** parameter('sta 0/1').

The available settings for the **Trigger Activation** parameter are:

- **Falling Edge:** Specifies that a falling edge of the electrical signal will act as the exposure start trigger.
- **Rising Edge:** Specifies that a rising edge of the electrical signal will act as the exposure start trigger.

### Exposure Time Control with Trigger Mode = On

When the **Trigger Mode** parameter is set to **On** and the **Trigger Source** parameter is set to **Software**, the exposure time for each frame acquisition is determined by the value of the camera's **Exposure Time** parameter.

When the **Trigger Mode** parameter is set to **On** and the **Trigger Source** parameter is set to **CC1** or **Line0**, the exposure time for each frame acquisition will be determined by the **Exposure Mode** parameter settings as follows:

- **Exposure Mode = Timed:** Exposure time can be controlled with the **Exposure Time** parameter.
- **Exposure Mode = Trigger Width:** Exposure time can be controlled by manipulating the external trigger signal.

When the **Trigger Mode** parameter is set to **On** and the **Trigger Source** parameter is set to **User Output0**, the exposure time for each frame acquisition will be determined by the **Exposure Mode** parameter settings as follows:

- **Exposure Mode = Timed:** Exposure time can be controlled with the **Exposure Time** parameter.
- **Exposure Mode = Trigger Width:** Exposure time can be controlled by switching the **User Output Value** parameter between **On** and **Off**.

### 8.3.2 Using a Software Trigger Signal

If the **Trigger Mode** parameter is set to **On('stm 1')** and the **Trigger Source** parameter is set to **Software('sts 3')**, you must apply a software trigger signal (exposure start) to the camera to begin each frame acquisition. Assuming that the camera is in a waiting for exposure start trigger acquisition status, frame exposure will start when the software trigger signal is received by the camera. The figure below illustrates frame acquisition with a software trigger signal.

When the camera receives a software trigger signal and begins exposure, it will exit the *waiting for exposure start trigger* acquisition status because at that point, it cannot react to a new exposure start trigger signal.

As soon as the camera is capable of reacting to a new exposure start trigger signal, it will automatically return to the waiting for exposure start trigger acquisition status.

The exposure time for each acquired frame will be determined by the value of the camera's **Exposure Time** parameter('set n').

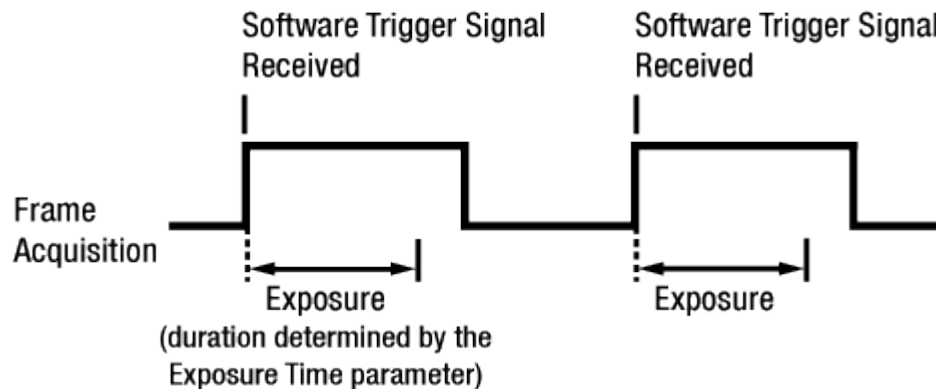

Figure 8-2 Frame Acquisition with Software Trigger Signal

When you are using a software trigger signal to start each frame acquisition, the frame rate will be determined by how often you apply a software trigger signal to the camera, and you should not attempt to trigger frame acquisition at a rate that exceeds the maximum allowed for the current camera settings (There is a detailed explanation about the maximum allowed frame rate at the end of this chapter.). Software trigger signals that are applied to the camera when it is not ready to receive them will be ignored.

### 8.3.3 Using a CC1 Trigger Signal

If the **Trigger Mode** parameter is set to **On** ('stm 1') and the **Trigger Source** parameter is set to **CC1** ('sts 14'), you must apply a CC1 trigger signal to the camera to begin each frame acquisition. A CC1 trigger signal will act as the exposure start trigger signal for the camera. For more information, refer to your Camera Link frame grabber user manual.

A rising edge or falling edge of the CC1 signal can be used to trigger frame acquisition. The **Trigger Activation** parameter ('sta 1/0') is used to select rising edge or falling edge triggering.

Assuming that the camera is in a *waiting for exposure start trigger* acquisition status, frame acquisition will start whenever the appropriate edge transition is received by the camera.

When the camera receives a CC1 trigger signal and begins exposure, it will exit the *waiting for exposure start trigger* acquisition status because at that point, it cannot react to a new exposure start trigger signal.

As soon as the camera is capable of reacting to a new exposure start trigger signal, it will automatically return to the *waiting for exposure start trigger* acquisition status.

When the camera is operating under control of a CC1 signal, the period of the CC1 trigger signal will determine the rate at which the camera is acquiring frames:

$$\frac{1}{\text{CC1 signal period in seconds}} = \text{Frame Rate}$$

For example, if you are operating a camera with a CC1 trigger signal period of 500 ms (0.5 s):  
So in this case, the frame rate is 2 fps.

### 8.3.4 Using an External Trigger Signal

If the **Trigger Mode** parameter is set to **On**('stm 1') and the **Trigger Source** parameter is set to **Line0**('sts 22'), an externally generated electrical signal injected into the Control I/O Receptacle will act as the exposure start trigger signal for the camera. This type of trigger signal is generally referred to as a hardware trigger signal.

A rising edge or a falling edge of the external signal can be used to trigger frame acquisition. The **Trigger Activation** parameter('sta 1/0') is used to select rising edge or falling edge triggering. Assuming that the camera is in a *waiting for exposure start trigger* acquisition status, frame acquisition will start whenever the appropriate edge transition is received by the camera.

When the camera receives an external trigger signal and begins exposure, it will exit the *waiting for exposure start trigger* acquisition status because at that point, it cannot react to a new exposure start trigger signal.

As soon as the camera is capable of reacting to a new exposure start trigger signal, it will automatically return to the *waiting for exposure start trigger* acquisition status.

When the camera is operating under control of an external signal, the period of the external trigger signal will determine the rate at which the camera is acquiring frames:

$$\frac{1}{\text{External signal period in seconds}} = \text{Frame Rate}$$

For example, if you are operating a camera with an External trigger signal period of 500ms (0.5 s):

So in this case, the frame rate is 2 fps.

## External Trigger Delay

When you set the Trigger Source parameter to `Timer0Active('sts 18')`, you can specify a delay between the receipt of a hardware trigger signal and when the trigger becomes effective.

1. Set the Timer Trigger Source parameter in the Digital I/O category to `Line0('stts 22')`.
2. Set the Timer Delay parameter ('stdl n') to the desired Timer delay in microseconds.
3. Set the Trigger Source parameter in the IMODE/EXP category to `Timer0Active('sts 18')`.
4. Execute the Acquisition Start command ('ast') and inject an externally generated electrical signal into the Control I/O Receptacle. Then, the delay set by the Timer Delay parameter expires and the exposure for image acquisition begins.

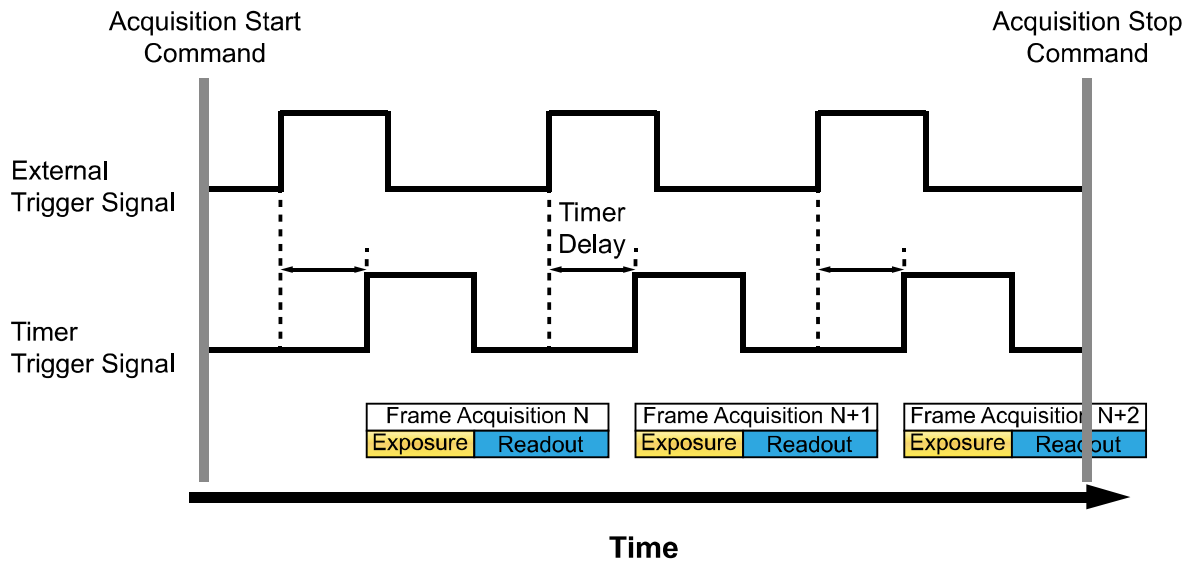

Figure 8-3 External Trigger Delay

### 8.3.5 Exposure Mode

If you are triggering the start of frame acquisition with an externally (CC1 or External) generated trigger signal, two exposure modes are available: Timed and Trigger Width('sem 0/1' or 'ses 0/1').

#### Timed Exposure Mode

When the Timed mode('sem 0' or 'ses 0') is selected, the exposure time for each frame acquisition is determined by the value of the camera's Exposure Time parameter('set n'). If the camera is set for rising edge triggering, the exposure time starts when the external trigger signal rises. If the camera is set for falling edge triggering, the exposure time starts when the external trigger signal falls. The following figure illustrates Timed exposure with the camera set for rising edge triggering.

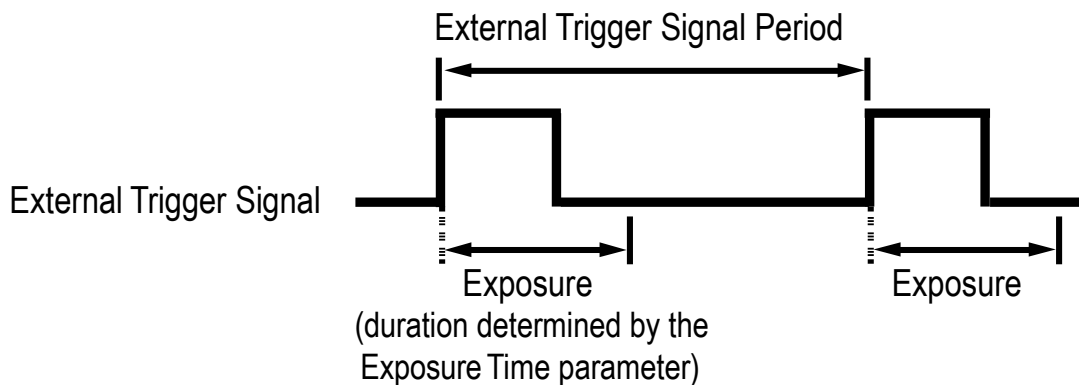

Figure 8-4 Timed Exposure Mode

Note that if you attempt to trigger a new exposure start while the previous exposure is still in progress, the trigger signal will be ignored.

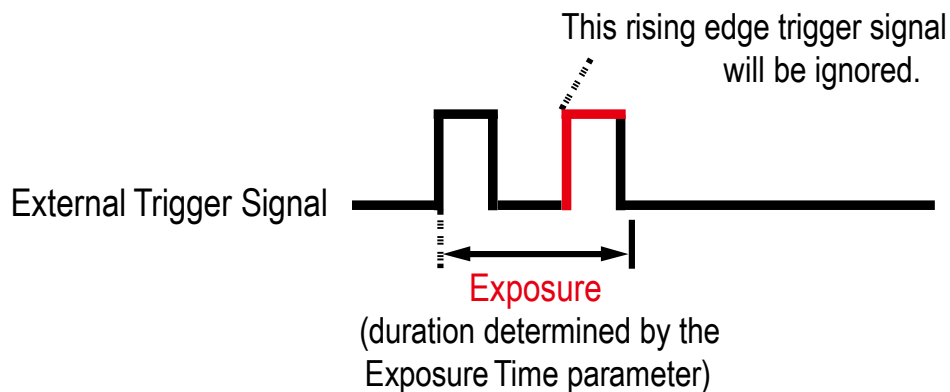

Figure 8-5 Trigger Overlapped with Timed Exposure Mode



### Trigger Width Exposure Mode

When the Trigger Width exposure mode ('sem 1' or 'ses 1') is selected, the length of the exposure for each frame acquisition will be directly controlled by the external trigger signal (CC1 or External). If the camera is set for rising edge triggering, the exposure time begins when the external trigger signal rises and continues until the external trigger signal falls. If the camera is set for falling edge triggering, the exposure time begins when the external trigger signal falls and continues until the external trigger signal rises. The following figure illustrates Trigger Width exposure with the camera set for rising edge triggering.

Trigger Width exposure is especially useful if you intend to vary the length of the exposure time for each frame.

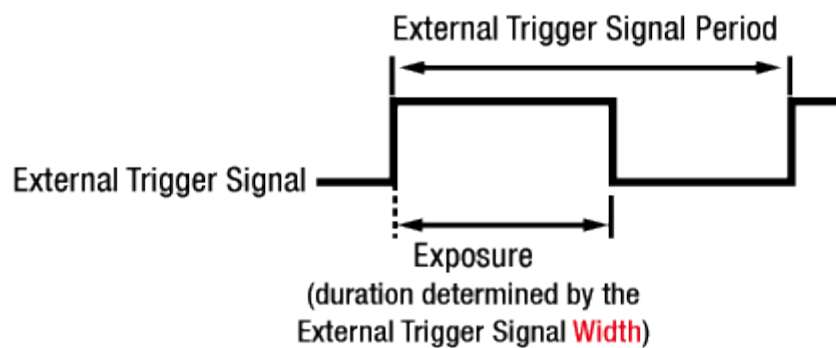

Figure 8-6 Trigger Width Exposure Mode

## 8.4 Setting the Exposure Time

This section describes how the exposure time can be adjusted manually by setting the value of the Exposure Time parameter. If you are operating the camera in any one of the following ways, you must specify an exposure time by setting the camera's Exposure Time parameter('set n').

- the Trigger Mode is set to Off('stm 0')
- the Trigger Mode is set to On('stm 1') and the Trigger Source is set to Software('stm 3').
- the Trigger Mode is set to On('stm 1'), the Trigger Source is set to CC1('sts 14') or Line0('sts 22'), and the Exposure Mode is set to Timed('sem 0' or 'ses 0').

The Exposure Time parameter must not be set below a minimum specified value. The Exposure Time parameter sets the exposure time in microseconds ( $\mu s$ ). The minimum and maximum exposure time settings for the VP-101MC/151MC cameras are shown in the following table.

Camera Model	Minimum Exposure Time	Maximum Exposure Time †
VP-101MC VP-151MC	1 $\mu s$	60,000,000 $\mu s$
†: When the Exposure Mode is set to Trigger Width, the exposure time is controlled by the external trigger signal and has no maximum limit.		

Table 8-1 Minimum and Maximum Exposure Time Setting

### 8.5 Rolling Shutter

The VP-101MC/151MC cameras are equipped with an image sensor that has an electronic rolling shutter. The camera exposes and reads out the pixel line with a temporal offset ( $t_{Row}$ ) from one line to the next. When a trigger signal is applied to the camera, the camera resets the top line of pixels (Line 1) and begins exposing that line. The camera resets line two  $t_{Row}$  later and begins exposing the line. And so on until the bottom line of pixels (Line N) is reached. The pixel values for each line are read out at the end of exposure for the line. The readout time for each line is identical to the  $t_{Row}$  value.

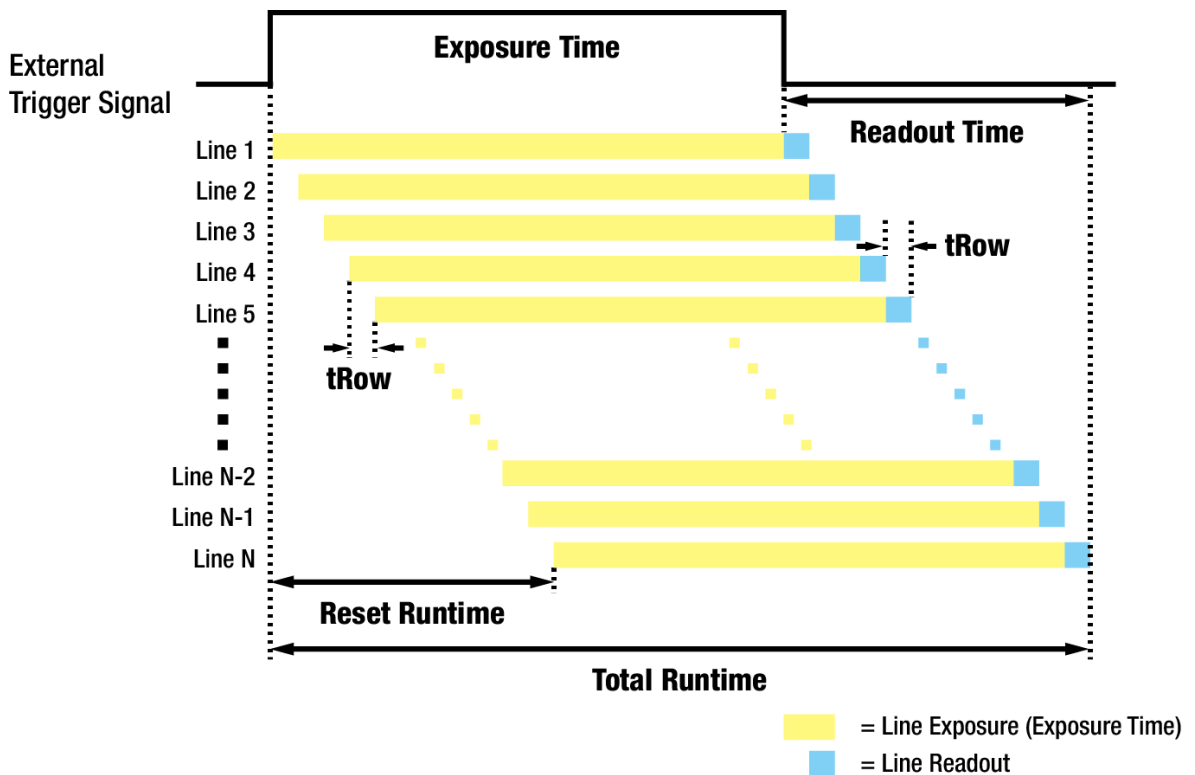

Figure 8-7 Rolling Shutter Operation

The tRow values depending on the VP-101MC camera's Camera Link Tap Geometry settings are as follows:

Camera Link Tap Geometry	tRow
2 Tap	12.91 $\mu$ s
4 Tap	12.91 $\mu$ s
8 Tap	12.91 $\mu$ s
10 Tap	12.91 $\mu$ s

Table 8-2 Temporal Offset Values depending on VP-101MC's Camera Link Tap Geometry

The tRow values depending on the VP-151MC camera's Camera Link Tap Geometry settings are as follows:

Camera Link Tap Geometry	tRow
2 Tap	15.0 $\mu$ s
4 Tap	15.0 $\mu$ s
8 Tap	15.0 $\mu$ s
10 Tap	15.0 $\mu$ s

Table 8-3 Temporal Offset Values depending on VP-151MC's Camera Link Tap Geometry

## 8.6 Overlapping Exposure with Sensor Readout

The frame acquisition process on the camera includes two distinct parts. The first part is the exposure of the pixels in the image sensor. Once exposure is complete, the second part of the process – readout of the pixel values from the sensor – takes place. In regard to this frame acquisition process, the VP-101MC/151MC cameras can be operated in the Overlapped acquisition mode or the Non-overlapped acquisition mode.

### 8.6.1 Overlapped Acquisition with Trigger Mode = Off

When the Trigger Mode parameter is set to Off ('stm 0', Free-run mode), the camera operates with 'overlapped' acquisition so that the exposure for a new frame can be overlapped with the sensor readout for the previous frame. The exposure of a new frame begins while the camera is still reading out the sensor data for the previously acquired frame.

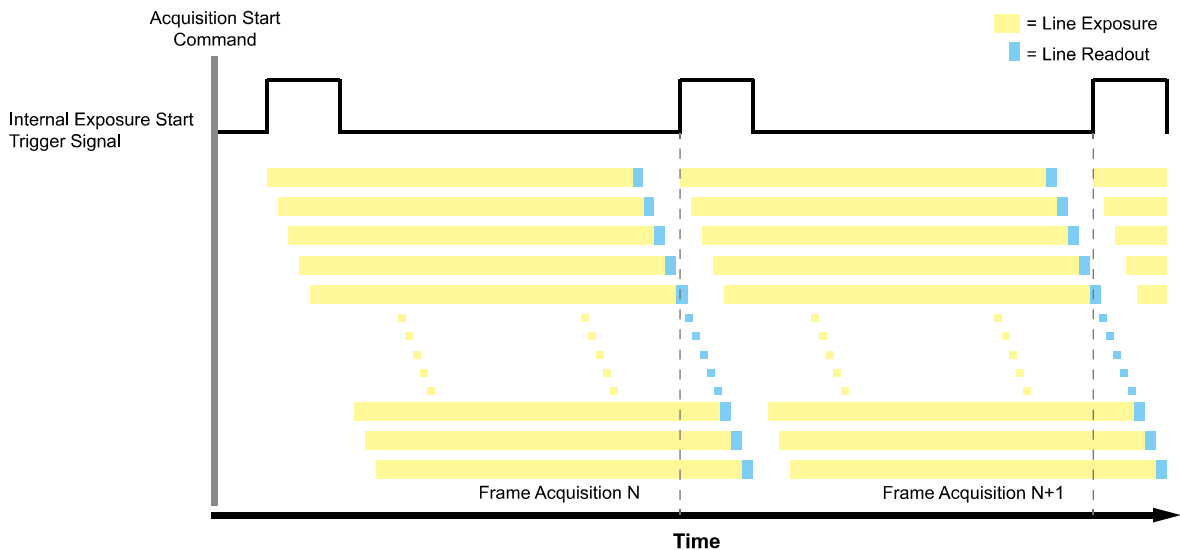

Figure 8-8 Overlapped Exposure and Readout

Determining whether your camera is operating with overlapped exposure and readout is not a matter of issuing a command or changing a setting. Rather a way that you operate the camera will determine whether the exposures and readouts are overlapped or not. If we define the "Frame Period" as the time from the start of exposure for frame acquisition N to the start of exposure for frame acquisition N+1, then:

- Non-overlap: Frame Period > Exposure Time + Readout Time
- Overlap: Frame Period ≤ Exposure Time + Readout Time

### 8.6.2 Overlapped Acquisition with Trigger Mode = On

#### Overlapped

When the Trigger Mode parameter is set to On ('stm 1'), each time a frame is acquired the camera basically completes the entire exposure/readout process before acquisition of the next frame is started. However, the VP-101MC/151MC cameras can be operated in the 'overlapped' acquisition mode when you operate the camera under the following condition. In this case, the camera can acquire images at the maximum frame rate.

$$\frac{1}{\text{Highest Possible Frame Rate}} \geq \text{Maximum Allowed Exposure Time for Overlapped Operation} + \text{Total Readout Time}$$

For example, if you want to acquire images at the maximum frame rate (3.2 fps) using the VP-101MC camera with the Camera Link Tap Geometry - 4 Tap setting, you must set the exposure time to a value less than 199,640 μs.

$$\text{Maximum Allowed Exposure Time for Overlapped Operation} \leq \frac{1}{3.2 \text{ fps}} - (8742 \times 12.91 \mu\text{s}) = 199,640 \mu\text{s}$$

When you want to acquire images at the maximum frame rate with the Trigger Mode parameter set to On, you must set the camera's exposure time to a value less than the maximum allowed exposure time for 'overlapped' operation. The maximum allowed exposure time for 'overlapped' operation of the VP-101MC camera is shown below.

Camera Link Tap Geometry	Highest Possible Frame Rate	Max. Exposure Time
2 Tap	1.6 fps	512,140 μs
4 Tap	3.2 fps	199,640 μs
8 Tap	6.5 fps	40,986 μs
10 Tap	8.1 fps	10,597 μs

Table 8-4 Max. Allowed Exposure Time for Overlapped Operation of VP-101MC

The maximum allowed exposure time for 'overlapped' operation of the VP-151MC camera is shown below.

Camera Link Tap Geometry	Highest Possible Frame Rate	Max. Exposure Time
2 Tap	1.1 fps	749,490 $\mu$ s
4 Tap	2.2 fps	294,945 $\mu$ s
8 Tap	4.4 fps	67,672 $\mu$ s
10 Tap	5.5 fps	22,218 $\mu$ s

Table 8-5 Max. Allowed Exposure Time for Overlapped Operation of VP-151MC

### Non-overlapped

When you set the **Trigger Mode** parameter to On ('stm 1') and set the exposure time to a value greater than the maximum allowed exposure time for overlapped operation (described in the preceding section), the camera completes the entire exposure/readout process for the frame N before acquisition of the frame N+1 is started. The exposure for a new frame does not overlap the sensor readout for the previous frame. The following figure illustrates the **Trigger Mode** parameter set to On ('stm 1'), the **Trigger Source** parameter set to Line0 ('sts 22'), and the **Exposure Mode** parameter set to Trigger Width ('sem 1' or 'ses 1').

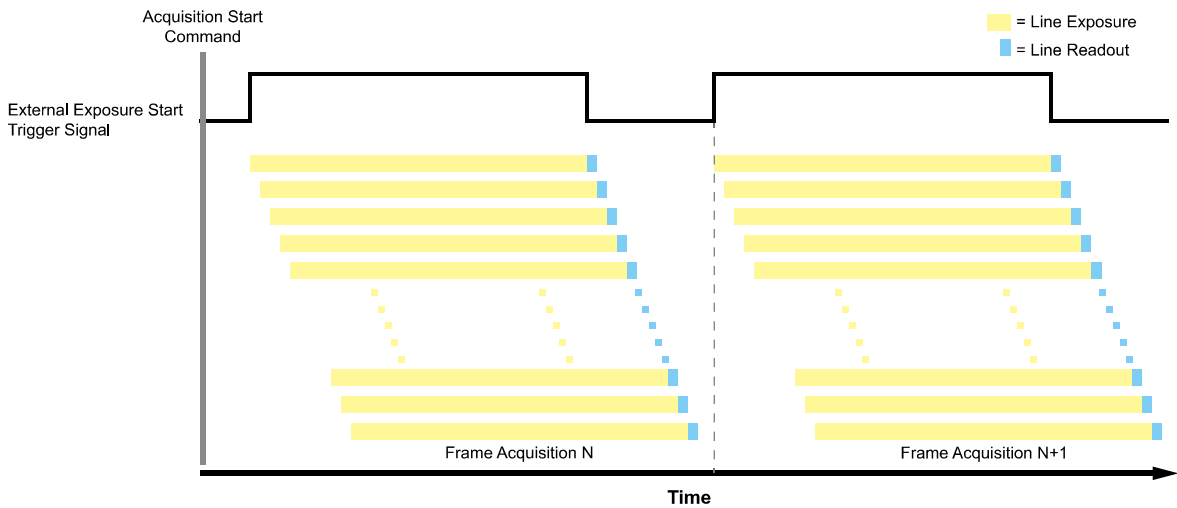

Figure 8-9 Non-overlapped Exposure and Sensor Readout

## 8.7 Maximum Allowed Frame Rate

In general, the maximum allowed acquisition frame rate on the camera may be limited by several factors:

- The amount of time that it takes to transmit an acquired frame from the camera to your computer. The amount of time needed to transmit a frame depends on the bandwidth assigned to the camera.
- The amount of time it takes to read an acquired frame out of the image sensor and into the camera's frame buffer. This time varies depending on the setting for the Height parameter. Frames with a smaller height take less time to read out of the sensor. You can set the frame height by executing the 'sih n' command.
- The Camera Link Tap Geometry. When the camera is set for a Camera Link Tap Geometry that uses more taps, it can typically transfer data out of the camera faster than when it is set for a Camera Link Tap Geometry that uses less taps.
- The exposure time for acquired frames. If you use very long exposure time, you can acquire fewer frames per second.



### 8.7.1 Increasing the Maximum Allowed Frame Rate

You may find that you would like to acquire frames at a rate higher than the maximum allowed with the camera's current settings. In this case, you must adjust one or more of the factors that can influence the maximum allowed frame rate and then check to see if the maximum allowed frame rate has increased.

- The time that it takes to transmit a frame out of the camera is the main limiting factor on the frame rate. You can decrease the frame transmission time (and thus increase the maximum allowed frame rate) by using the ROI feature.
- Decreasing the size of the Image ROI may increase the maximum allowed frame rate. If possible, decrease the height of the Image ROI.
- If you have set the Camera Link Pixel Clock speed to a low value, consider setting it to a higher value. Before setting the camera's Pixel Clock to a higher value, make sure that your frame grabber is compatible with the higher Pixel Clock speed.
- If you are using a Camera Link Tap Geometry with a low number of taps, consider using a Camera Link Tap Geometry with a high number of taps. This will usually increase the maximum allowed frame rate.
- If you are using normal exposure times and you are using the camera at its maximum resolution, your exposure time will not normally restrict the frame rate. However, if you are using long exposure time, it is possible that your exposure time is limiting the maximum allowed frame rate. If you are using a long exposure time, try using a shorter exposure time and see if the maximum allowed frame rate increases (You may need to compensate for a lower exposure time by using a brighter light source or increasing the opening of your lens aperture.).

**Note:**

A very long exposure time severely limits the camera's maximum allowed frame rate. As an example, assume that your camera is set to use a 1 second exposure time. In this case, because each frame acquisition will take at least 1 second to be completed, the camera will only be able to acquire a maximum of one frame per second.

---

## Chapter 9. Camera Features

### 9.1 Image Region of Interest

The Image Region of Interest (ROI) feature allows you to specify a portion of the sensor array. You can acquire only the frame data from the specified portion of the sensor array while preserving the same quality as you acquire a frame from the entire sensor array.

With the ROI feature, you can increase the maximum allowed frame rate by decreasing the **Height** parameter; however, decreasing the **Width** parameter does not affect the frame rate.

The ROI is referenced to the top left corner [origin (0, 0)] of the sensor array as shown below.

The commands related to Image ROI are as follows.

Command		Value	Description
ROI Width	siw	-	Sets the Width of the Image ROI.
ROI Height	sih	-	Sets the Height of the Image ROI.
ROI Offset X	sox	-	Sets the horizontal offset from the origin to the Image ROI.
ROI Offset Y	soy	-	Sets the vertical offset from the origin to the Image ROI.

Table 9-1 Commands related to ROI

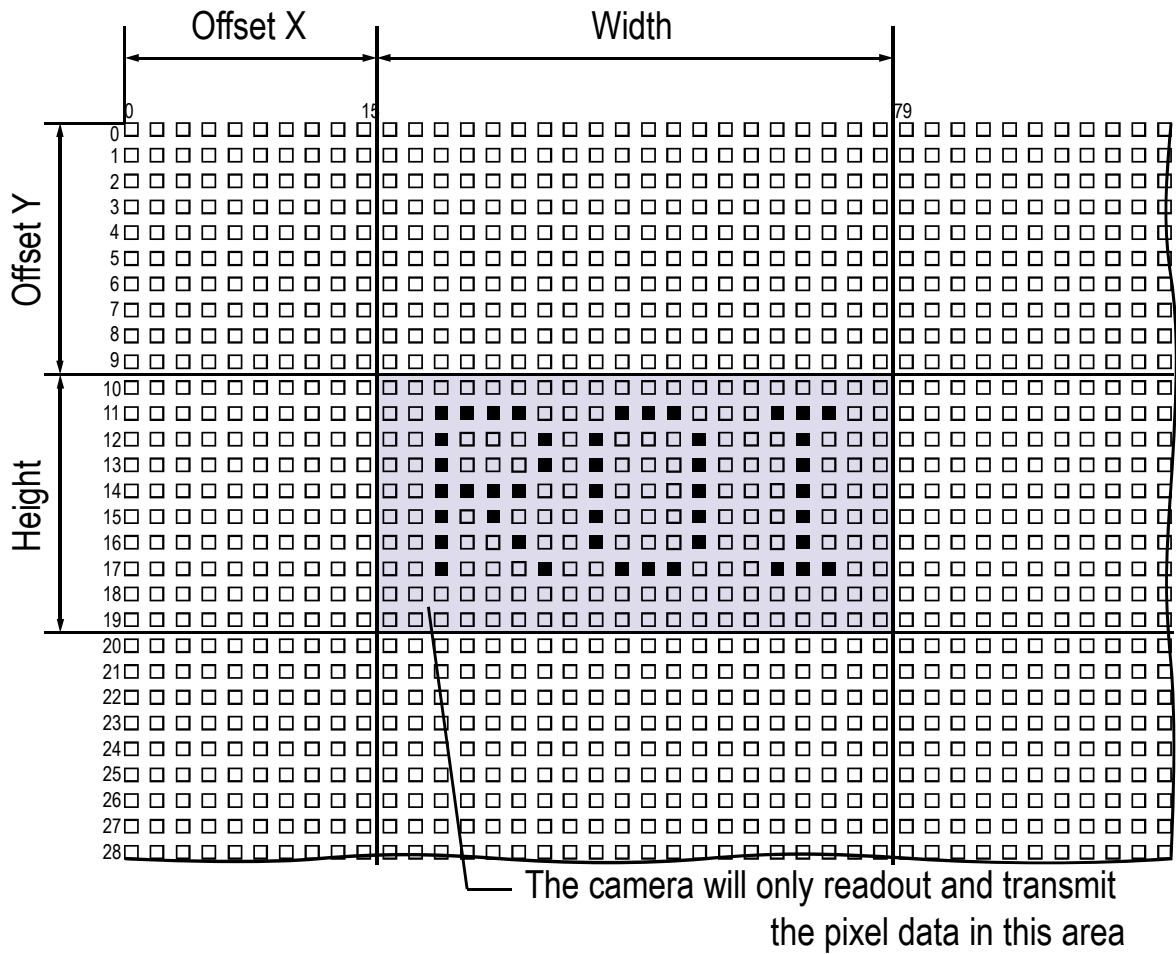

Figure 9-1 Region of Interest

You can change the size of ROI by setting the Width and Height parameters in the Image Format Control category. You must set the size of the ROI first, and then set the Offset values since the Width and Height parameters are set to its maximum value by default.

- On the VP-101MC/151MC cameras, the Width parameter must be set to a multiple of 16, and the Height parameter must be set to a multiple of 2.

The minimum allowed setting values for the ROI Offset X, Offset Y, Width and Height are shown below.

Camera Model	Minimum Offset X	Minimum Width	Minimum Offset Y	Minimum Height
VP-101MC	16	64	2	2
VP-151MC				

Table 9-2 Minimum ROI Offset X, Offset Y, Width and Height Settings



**Caution!**

When you change the Image ROI settings after executing the Acquisition Start command ('ast'), the camera may acquire abnormal images. Change the Image ROI settings after executing the Acquisition Stop command ('asp').

On the VP-101MC camera, the maximum allowed frame rates depending on Vertical ROI changes are shown below.

ROI Size (H × V)	2 Tap	4 Tap	8 Tap	10 Tap
11648 × 2	127 fps	255 fps	509 fps	635 fps
11648 × 2000	6.9 fps	13.7fps	27.4 fps	34.3 fps
11648 × 4000	3.5 fps	7.0 fps	14.1 fps	17.6 fps
11648 × 6000	2.3 fps	4.7 fps	9.4 fps	11.8 fps
11648 × 8000	1.7 fps	3.5 fps	7.1 fps	8.9 fps
11648 × 8742	1.6 fps	3.2 fps	6.5 fps	8.1 fps

Table 9-3 Maximum Frame Rates by VP-101MC Vertical ROI Changes (@ Pixel Clock 85MHz)

On the VP-151MC camera, the maximum allowed frame rates depending on Vertical ROI changes are shown below.

ROI Size (H × V)	2 Tap	4 Tap	8 Tap	10 Tap
14192 × 2	98 fps	195 fps	390 fps	488 fps
14192 × 2000	5.6 fps	11.2 fps	22.4 fps	28.0 fps
14192 × 4000	2.9 fps	5.8 fps	11.5 fps	14.4 fps
14192 × 6000	1.9 fps	3.9 fps	7.7 fps	9.7 fps
14192 × 8000	1.4 fps	2.9 fps	5.8 fps	7.3 fps
14192 × 10640	1.1 fps	2.2 fps	4.4 fps	5.5 fps

Table 9-4 Maximum Frame Rates by VP-151MC Vertical ROI Changes (@ Pixel Clock 85MHz)



**Caution!**

Your Frame Grabber may place additional restrictions on how the ROI location and size must be set. Refer to your Frame Grabber user manual for more information.

## 9.2 Binning (Monochrome Only)

The Binning has the effects of increasing the level value and decreasing resolution by summing the values of the adjacent pixels and sending them as one pixel. The commands related to Binning are as follows.

Command		Value	Description
Binning Selector	sbns	0: Sensor	Selects the Sensor for the binning engine. Applies the Binning in analog by the image sensor.
		1: Logic	Selects the Logic for the binning engine. Applies the Binning in digital by the logic.
Binning Horizontal Mode	sbhm	0: Sum	According to the Binning Selector setting: <ul style="list-style-type: none"> <li>Sensor: N/A</li> <li>Logic: Adds pixel values from the adjacent pixels as specified in the Binning Horizontal, and then sends them as one pixel.</li> </ul>
		1: Average	According to the Binning Selector setting: <ul style="list-style-type: none"> <li>Sensor: Updated automatically according to the Binning Vertical Mode.</li> <li>Logic: Adds pixel values from the adjacent pixels as specified in the Binning Horizontal and divides them by the number of combined pixels, and then sends them as one pixel.</li> </ul>
Binning Horizontal	sbh	×1, ×2, ×3, ×4	According to the Binning Selector setting: <ul style="list-style-type: none"> <li>Sensor: Updated automatically according to Binning Vertical.</li> <li>Logic: The number of horizontal pixels to combine together (×1, ×2, ×4).</li> </ul>
Binning Vertical Mode	sbvm	0: Sum	According to the Binning Selector setting: <ul style="list-style-type: none"> <li>Sensor: N/A</li> <li>Logic: Adds pixel values from the adjacent pixels as specified in the Binning Vertical, and then sends them as one pixel.</li> </ul>
		1: Average	Adds pixel values from the adjacent pixels as specified in the Binning Vertical and divides them by the number of combined pixels, and then sends them as one pixel.
Binning Vertical	sbv	×1, ×2, ×3, ×4	The number of vertical pixels to combine together: <ul style="list-style-type: none"> <li>Sensor: ×1, ×3</li> <li>Logic: ×1, ×2, ×4</li> </ul>

Table 9-5 Commands related to Binning



### Caution!

- When the Binning Selector is set to Sensor, the Average Binning is only available.
- When the Binning Selector is set to Sensor, ×1 or ×3 is only available.
- When the Binning Selector is set to Logic, ×1, ×2 or ×4 is only available.
- The binning feature is only available with serial commands and not supported in Configurator.

For example, if you set the **Binning Selector** to **Logic** and set  $2 \times 2$  binning, the camera's resolution is reduced to  $1/4$ . If you set the **Binning Horizontal/Vertical Mode** to **Sum**, the maximum allowed resolution of the image is reduced to  $1/2$  and the responsivity of the camera is quadrupled. If you set the **Binning Horizontal/Vertical Mode** to **Average**, the maximum allowed resolution of the image is reduced to  $1/2$ , but there is no difference in responsivity between a binned image and an original image.

You can also use both the Sensor and Logic binning engines simultaneously. For example, you can set the **Binning Selector** to **Sensor**, **Binning Horizontal/Vertical Mode** to **Average**, and the **Binning Vertical** to  $\times 3$ . Then, you can set the **Binning Selector** to **Logic**, **Binning Horizontal/Vertical Mode** to **Average**, and the **Binning Horizontal/Vertical** to  $\times 4$ . With these settings, you can implement  $12 \times 12$  binning.

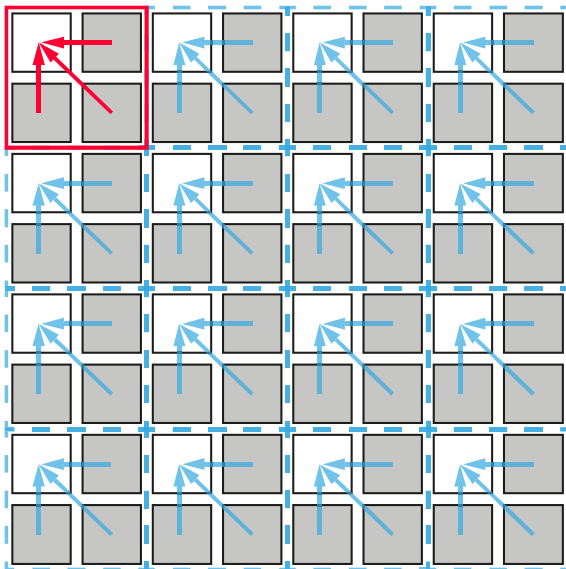

Figure 9-2  $2 \times 2$  Binning

### 9.3 Pixel Format

You can determine the pixel format (8 bits, 10 bits or 12 bits) of image data transmitted from the camera by using the 'sdb 8/10/12' command.

The command related to Pixel Format is as follows.

Command		Value	Description
Pixel Format	sdb	8	Sets the pixel format to 8-bit.
		10	Sets the pixel format to 10-bit.
		12	Sets the pixel format to 12-bit.

Table 9-6 Command related to Pixel Format

### 9.4 Camera Link Tap Geometry

The VP-101MC/151MC cameras support 2 Tap, 4 Tap, 8 Tap and 10 Tap Camera Link Tap Geometry. The number of taps represents the number of pixel data that will be output on each cycle of the Camera Link Pixel Clock. The maximum allowed frame rate will be changed according to the Camera Link Tap Geometry settings. The image data is transmitted in the interleaved order as shown in the figure below.

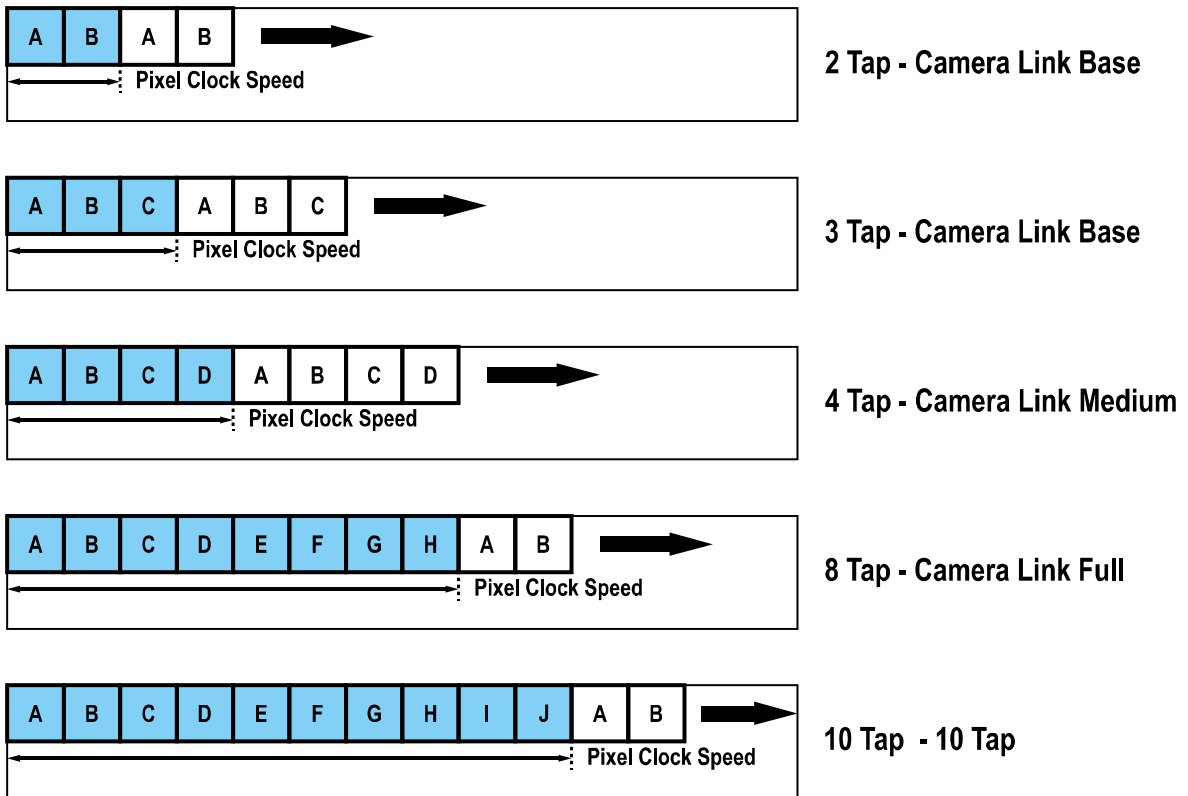

Figure 9-3 Camera Link Tap Geometry

The command related to Camera Link Tap Geometry is as follows.

Command	Value	Description
Camera Link Tap Geometry	2: 1X2-1Y	Sets the Camera Link Tap Geometry to 2 Tap.
	4: 1X4-1Y	Sets the Camera Link Tap Geometry to 4 Tap.
	8: 1X8-1Y	Sets the Camera Link Tap Geometry to 8 Tap.
	10: 1X10-1Y	Sets the Camera Link Tap Geometry to 10 Tap.

Table 9-7 Command related to Camera Link Tap Geometry



## 9.5 Camera Link Pixel Clock Speed

The VP-101MC/151MC cameras provide selectable Camera Link Pixel Clock speeds. The Pixel Clock speed determines that the rate at which pixel data will be transmitted from the camera to the frame grabber in your computer via the Camera Link interface. Setting the camera for a higher Pixel Clock speed will increase the rate at which image data is transferred from the camera to the frame grabber. Before setting the camera's Pixel Clock speed, make sure you determine the maximum Pixel Clock speed supported by your frame grabber. Then, you should not attempt to set the camera's Pixel Clock speed that exceeds the maximum Pixel Clock speed for your frame grabber.

The command related to Camera Link Pixel Clock speed is as follows.

Command		Value	Description
Camera Link Pixel Clock Speed	sccs	0: 85 MHz	Sets the Camera Link Pixel Clock speed to 85 MHz.
		1: 65 MHz	Sets the Camera Link Pixel Clock speed to 65 MHz.

Table 9-8 Command related to Camera Link Pixel Clock Speed

### 9.6 AWB ROI (Color Camera)

The Auto White Balance feature provided by the color camera uses the pixel data from an AWB Region of Interest (ROI) to adjust the white balance. The commands related to AWB ROI are as follows.

Command	Value	Description
AWB Offset X	swx	X coordinate of start point ROI
AWB Offset Y	swy	Y coordinate of start point ROI
AWB Width	sww	Width of ROI
AWB Height	swh	Height of ROI

Table 9-9 Commands related to AWB ROI

Only the pixel data from the area of overlap between the AWB ROI by your settings and the Image ROI will be effective if you use the Image ROI and the AWB ROI at the same time. The effective ROI is determined as shown in the figure below.

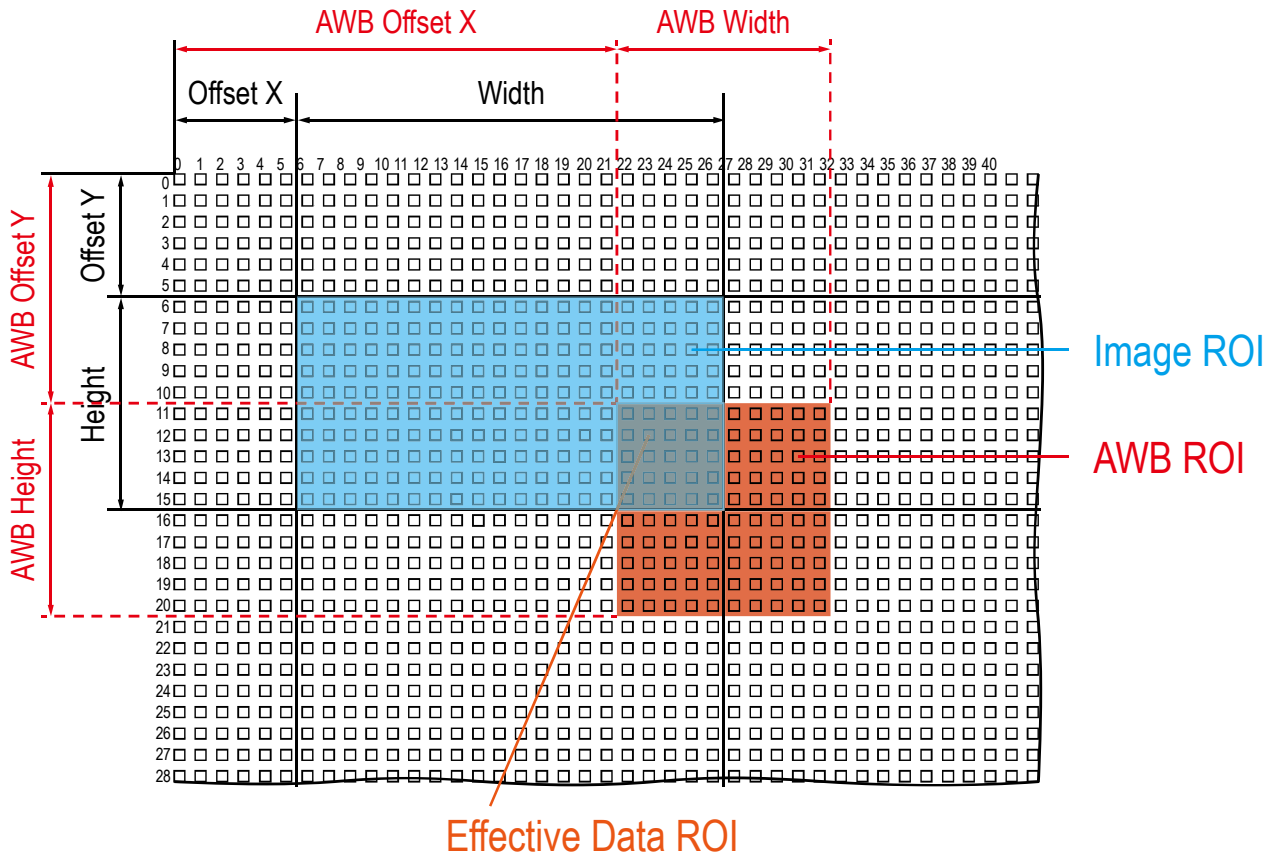

Figure 9-4 Effective Data ROI

## 9.7 White Balance (Color Only)

The color camera includes the white balance capability to adjust the color balance of the images acquired from the image sensor. With the white balancing scheme used on the VP-101MC/151MC cameras, the Red, Green and Blue intensities can be adjusted individually. You can set the intensity of each color by using the 'srg' command. The intensity value can range from 1.0 to 4.0. If you set the 'srg r / g / b' command to 1.0 for a color, the intensity of the color will be unaffected by the white balance mechanism. If you set the 'srg r / g / b' command to greater than 1.0, the intensity of the color will be proportionally increased to the ratio.

For example, if you execute the 'srg b 1.5' command, the blue intensity will be increased by 50%.

The commands related to White Balance are as follows.

Command	Value	Description
RGB Gain	srg r	1.0× ~ 4.0×
	srg g	1.0× ~ 4.0×
	srg b	1.0× ~ 4.0×
		Sets the intensity of the red pixels.
		Sets the intensity of the green pixels.
		Sets the intensity of the blue pixels.

Table 9-10 Command related to White Balance

### 9.7.1 Auto White Balance

The Auto White Balance feature is implemented on the color camera. It will control the white balance of the image acquired from the color camera according to the GreyWorld algorithm. Before using the Auto White Balance feature, you need to set the AWB ROI. If you do not set the AWB ROI, the pixel data from the Image ROI will be used to control the white balance. As soon as you execute the 'arg' command, the intensity values for Red and Blue will be automatically adjusted to adjust the white balance by referring to Green.

The command related to Auto White Balance is as follows.

Command	Value	Description
Auto White Balance	arg	-
		White Balance is adjusted once and then Off.

Table 9-11 Command related to Auto White Balance

## 9.8 Gain and Black Level

Increasing the **Gain** value by using the **Gain** command ('sdg n') increases all pixel values of the image. This results in a higher grey value output from the camera for a given amount of output from the image sensor.

Adjusting the **Black Level** value by using the **Black Level** command ('sbl n') results in an offset to the pixel values output from the camera.

The commands related to **Gain** and **Black Level** are as follows.

Command		Value	Description
Gain	sdg	1.0× ~ 32.0×	Sets a digital gain value.
Black Level	sbl	0 ~ 255	Sets a black level value (The setting range is based on the 12-bit Pixel Format.).

Table 9-12 Commands related to Gain and Black Level

## 9.9 Hot Pixel Correction

When you acquire images with long exposure times or operate the camera under the condition of high ambient temperature, hot pixels may be appeared on the images due to the characteristics of the high resolution CMOS image sensor. The VP-101MC/151MC cameras provide the Hot Pixel Correction feature to remove hot pixels.

The command related to Hot Pixel Correction is as follows.

Command		Value	Description
Hot Pixel Correction	sdsnup	0: Off	Disables the Hot Pixel Correction feature.
		1: On	Enables the Hot Pixel Correction feature.

Table 9-13 Command related to Hot Pixel Correction

## 9.10 Dynamic Defective Pixel Correction

When you acquire images with the Defective Pixel Correction feature (refer to 9.11 Defective Pixel Correction) enabled, some pixels may appear brighter or darker than the other pixels due to long exposure times, high gain settings or high operating temperatures. The VP-101MC/151MC cameras provide the Dynamic Defective Pixel Correction feature to remove these defect pixels. If you execute the 'sddc 1' command, pixels considerably brighter or darker than adjacent pixels will be replaced with the Median value of adjacent 3 × 3 pixels. You can adjust the range of defect pixel values to be replaced with the Median value by using the Defective Pixel Offset Threshold command ('shpo/scpo n').

The commands related to Dynamic Defective Pixel Correction are as follows.

Command		Value	Description
Dynamic Defective Pixel Correction	sddc	0: FALSE	Disables the Dynamic DPC feature.
		1: TRUE	Enables the Dynamic DPC feature.
+ Defective Pixel Offset Threshold	shpo	0 ~ 2048 (at 12 bit)	Sets the + Threshold Offset value of the Median filter.
- Defective Pixel Offset Threshold	scpo	0 ~ 2048 (at 12 bit)	Sets the - Threshold Offset value of the Median filter.

Table 9-14 Commands related to Dynamic Defective Pixel Correction

The range of defect pixel values can be determined by  $\pm 20\%$  of adjacent  $3 \times 3$  pixels' average and  $\pm$ Offset Threshold values.

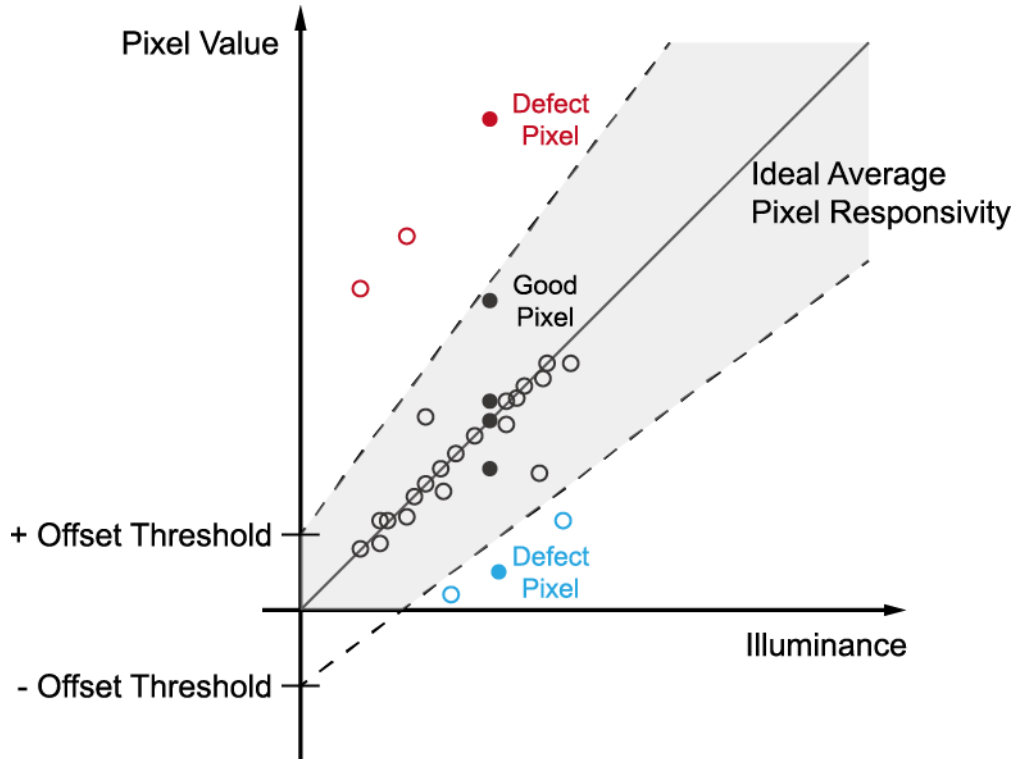

Figure 9-5 Dynamic Defective Pixel Correction

## 9.11 Defective Pixel Correction

The CMOS sensor may have defect pixels which cannot properly react to the light. Correction is required since it may deteriorate the quality of output image. Defect pixel information of CMOS used for each camera is entered into the camera during the manufacturing process. If you want to add defect pixel information, it is required to enter coordinate of new defect pixel into the camera. For more information, refer to Appendix A.

### 9.11.1 Correction Method

A correction value for a defect pixel is calculated based on the valid pixel value adjacent in the same line.

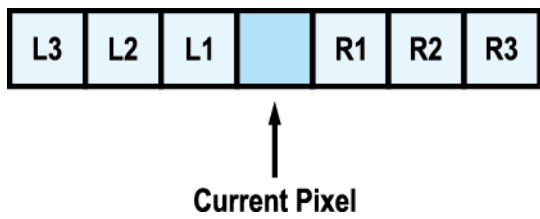

Figure 9-6 Location of Defect Pixel to be corrected

If the Current Pixel is a defect pixel as shown in the figure above, the correction value for this pixel is obtained as shown in the following table depending on whether surrounding pixels are defect pixels or not.

Adjacent Defect Pixel (s)	Correction Value of Current Pixel
None	$(L1 + R1) / 2$
L1	R1
R1	L1
L1, R1	$(L2 + R2) / 2$
L1, R1, R2	L2
L2, L1, R1	R2
L2, L1, R1, R2	$(L3 + R3) / 2$
L2, L1, R1, R2, R3	L3
L3, L2, L1, R1, R2	R3

Table 9-15 Calculation of Defect Pixel Correction Value

## 9.12 Flat Field Correction

The Flat Field Correction feature improves the image uniformity when you acquire a non-uniformity image due to external conditions. The Flat Field Correction feature of the VP-101MC/151MC cameras can be summarized by the following equation:

$$IC = (IR \times M) / IF$$

IC: Level value of corrected image  
 IR: Level value of original image  
 M: Target value of image after correction  
 IF: Level value of Flat Field data

The commands related to Flat Field Correction are as follows.

Command	Value	Description
Set Flat Field Correction	0: Off	Disables the Flat Field Correction feature.
	1: On	Enables the Flat Field Correction feature.
Flat Field Data Selector	sfdc 0 ~ 15	Selects a location to save or load Flat Field data from. <ul style="list-style-type: none"> <li>0 ~ 15: User defined locations</li> </ul>
Generate Flat Field Data	gfd none / 0	Auto-adjusts the target value of the image after correction, and then generates the Flat Field data.
	1 ~ 4095	Manually sets the target value of the image after correction, and then generates the Flat Field data (The setting range is based on the 12-bit Pixel Format.).
Save Flat Field Data	sfd -	Saves the generated Flat Field correction data in the non-volatile memory. <ul style="list-style-type: none"> <li>The data generated by executing the Generate Flat Field Data is saved in the volatile memory so that the data is lost if the camera is reset or if power is turned off. To use the data after the camera is powered on or reset, save it in the non-volatile memory.</li> </ul>
Load Flat Field Data	lfd -	Loads the Flat Field correction data from the non-volatile memory into the volatile memory.

Table 9-16 Commands related to Flat Field Correction



### 9.12.1 Sequence of Flat Field Correction

Under actual use conditions, generate Flat Field Correction data and save the Flat Field Correction data into the camera's non-volatile memory according to the following procedure.

#### How to generate Flat Field Correction data using Configurator

1. Select the FFC tab and then click the **Generate** button in the **FFC Data / Selector** category.  
After clicking the **Generate** button, you must acquire one image to generate the scaled-down Flat Field correction data.
2. Use the **Selector** dropdown list in the **FFC Data / Selector** category to specify a location to save the generated Flat Field correction data.
3. Click the **Save to Flash** button in the **Flash Memory** category to save the generated Flat Field correction data into the non-volatile memory. The scaled-down Flat Field correction data will be expanded and then applied as shown in the **Figure 9-9** when it is used for correction.

To disregard the generated Flat Field correction data and use the previous Flat Field correction data, click the **Load from Flash** button before clicking the **Save to Flash** button.

4. In the VIEW tab, select the Flat Field Corr. check box to apply the Flat Field correction data to the camera.

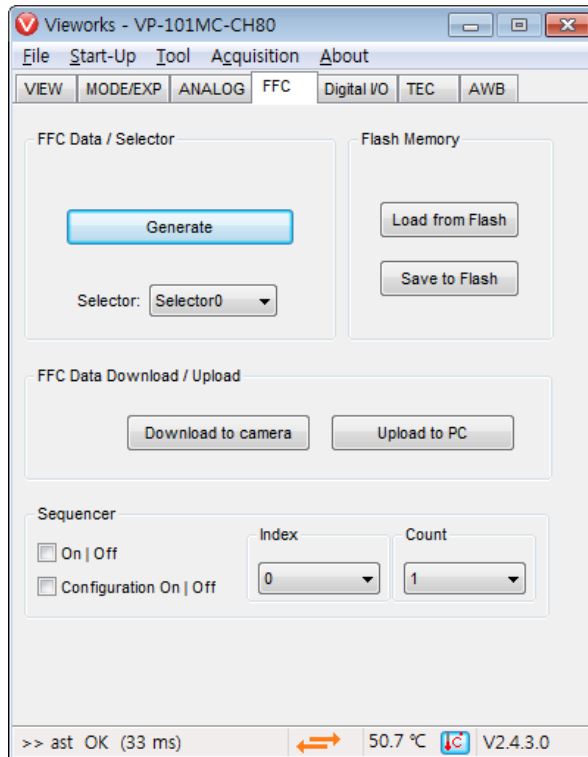

Figure 9-7 Flat Field Correction in Configurator

### How to generate Flat Field Correction data using Serial Command

1. Execute the 'gfd' command.
  - To set the user-defined target value of the image after correction, execute the 'gfd n' command.
  - After executing the 'gfd' command, you must acquire one image to generate the scaled-down Flat Field correction data.
2. Use the 'sfd 0/1/.../15' command to specify a location to save the generated Flat Field correction data.
3. Execute the 'sfd' command to save the generated Flat Field correction data into the non-volatile memory. The scaled-down Flat Field correction data will be expanded and then applied as shown in the **Figure 9-9** when it is used for correction.
  - To disregard the generated Flat Field correction data and use the previous Flat Field correction data, execute the 'lfd' command before using the 'sfd' command.
4. Execute the 'sfc 1' command to apply the Flat Field correction data to the camera.



#### Caution!

- It is recommended that you enable the Defective Pixel Correction feature ('sdc 1') before generating the Flat Field correction data.
  - Before executing the 'gfd' command, you must set the camera as follows:  
OffsetX, Y: 0  
Width, Height: Maximum values
  - After executing an Acquisition Start command ('ast'), you need to operate the camera in the free-run mode or apply a trigger signal to acquire an image.
  - To set the Flat Field Target Level manually, use the serial commands. The Configurator does not support setting the user-defined Flat Field Target Level.
-

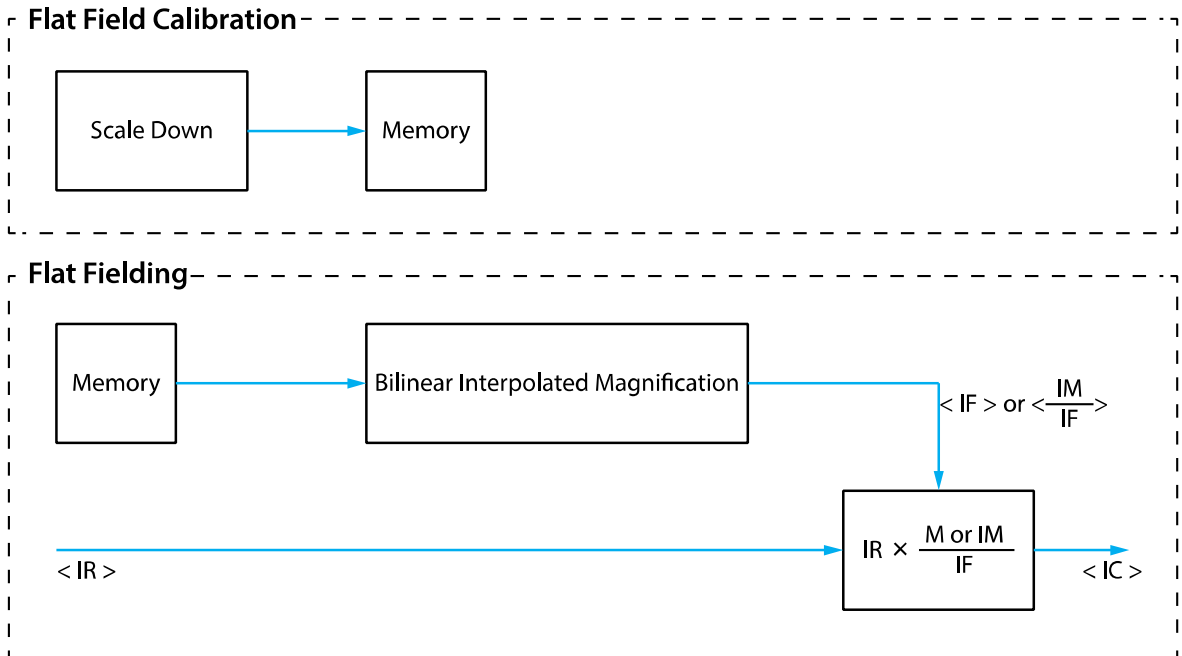

Figure 9-8 Generation and Application of Flat Field Data

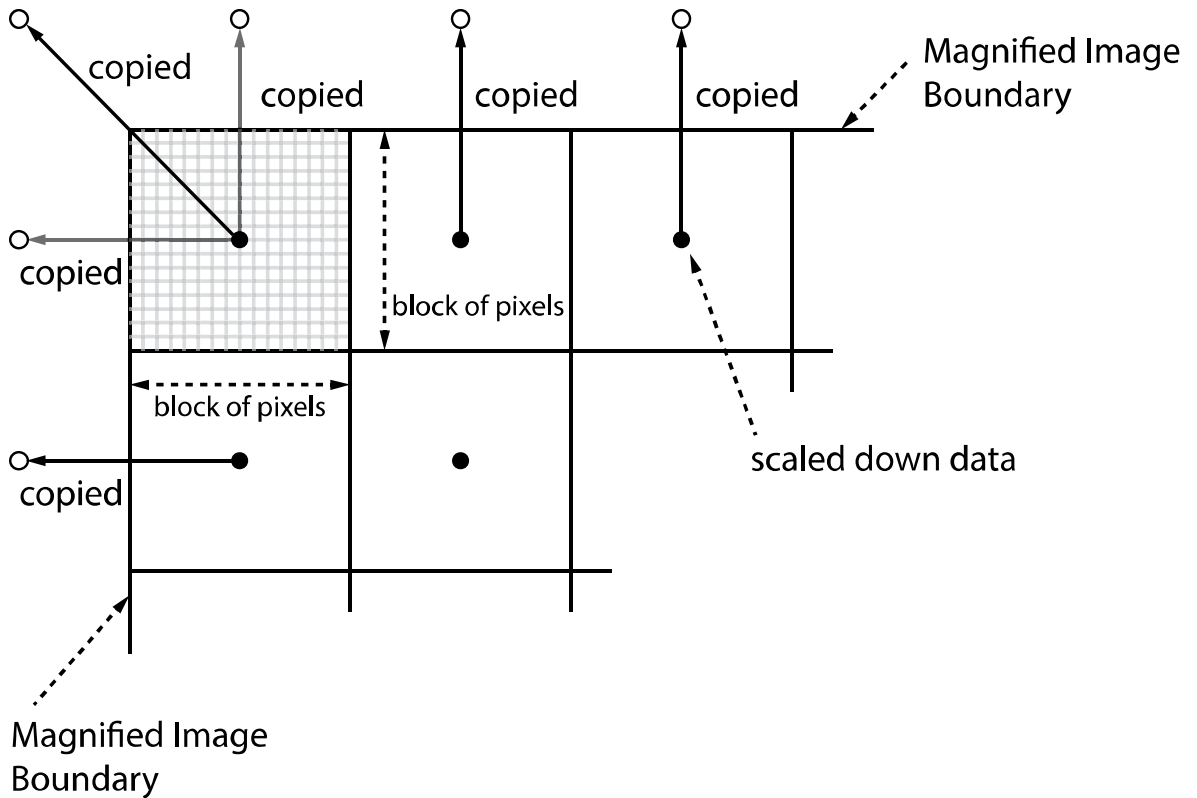

Figure 9-9 Bilinear Interpolated Magnification

### 9.12.2 Flat Field Data Selector

As mentioned above, the generated Flat Field correction data is stored in the camera's volatile memory and the data is lost if the camera is reset or powered off. To use the generated Flat Field correction data after the camera is powered on or reset, you need to save them in the camera's non-volatile memory. The VP-101MC/151MC cameras provide sixteen reserved locations in the camera's non-volatile memory available for saving and loading the Flat Field correction data. You can use the Flat Field Data Selector command ('sdfs 0/1/.../15') to select a location as desired.

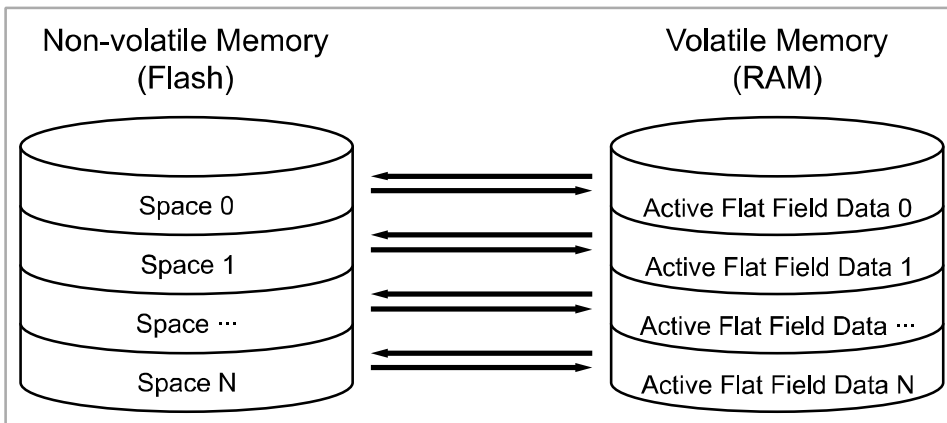

Figure 9-10 Flat Field Data Selector

### Saving Flat Field Data

There is a one-to-one correspondence between active Flat Field data locations in the volatile memory and Flat Field data storage locations in the non-volatile memory. In order to save the generated Flat Field data into a reserved location in the camera's flash memory, you must choose a Flat Field data location before generating Flat Field data by using the **Flat Field Data Selector** command.

1. Use the 'sfd 0/1/.../15' command to specify a location, and then generate Flat Field data.
2. Execute the 'sfd' command or click the **Save to Flash** button in the Configurator to save the generated Flat Field data to the selected location.

### Loading Flat Field Data

If Flat Field data are saved in the camera's non-volatile memory, you can load the saved Flat Field data from the camera's non-volatile memory into the camera's active Flat Field correction data location.

1. Use the 'sfd 0/1/.../15' command to specify the desired Flat Field data storage location. The Flat Field correction data will be applied when the Flat Field Correction feature is enabled on the camera.
2. To ignore newly generated Flat Field correction data and load the previous Flat Field correction data, execute the 'lfd' command.

### 9.13 Digital I/O Control

The control I/O receptacle of the camera can be operated in various modes.

The commands related to Digital I/O Control are as follows.

Command		Value	Description
Line Inverter	slni	0: FALSE	Disables inversion on the output signal of the line.
		1: TRUE	Enables inversion on the output signal of the line.
Line Source	slnc	0: Off	Disables the line output.
		4: Frame Active	Outputs pulse signals indicating a frame readout time.
		6: Exposure Active	Outputs pulse signals indicating the current exposure time.
		10: User Output0	Outputs pulse signals set by the User Output Value.
		18: Timer0 Active	Outputs user-defined Timer signals as pulse signals.
		30: Strobe	Outputs strobe signals (goes high when the exposure time for the bottom line of pixels begins and goes low when the exposure time for the top line of pixels ends) as pulse signals.
User Output Value	suov	0: FALSE	Sets the bit state of the line to Low.
		1: TRUE	Sets the bit state of the line to High.

Table 9-17 Commands related to Digital I/O Control

When you set the Line Source to User Output0, you can use the user setting values as output signals.

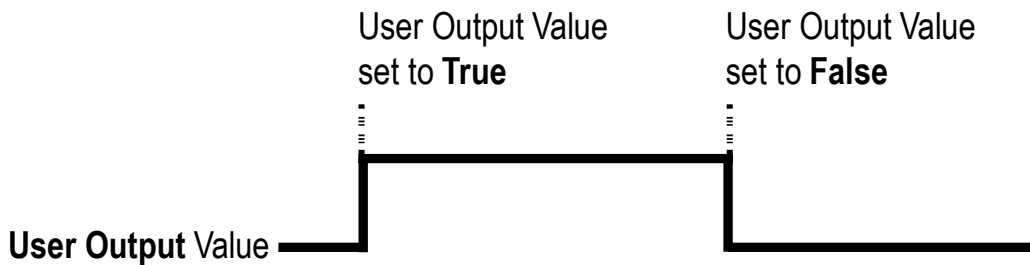

Figure 9-11 User Output

The camera can provide an Exposure Active output signal. The signal goes high when the exposure time for each frame acquisition begins and goes low when the exposure time ends as shown in the figure below. This signal can be used as a flash trigger and is also useful when you are operating a system where either the camera or the object being imaged is movable. Typically, you do not want the camera to move during exposure. You can monitor the Exposure Active signal to know when exposure is taking place and thus know when to avoid moving the camera.

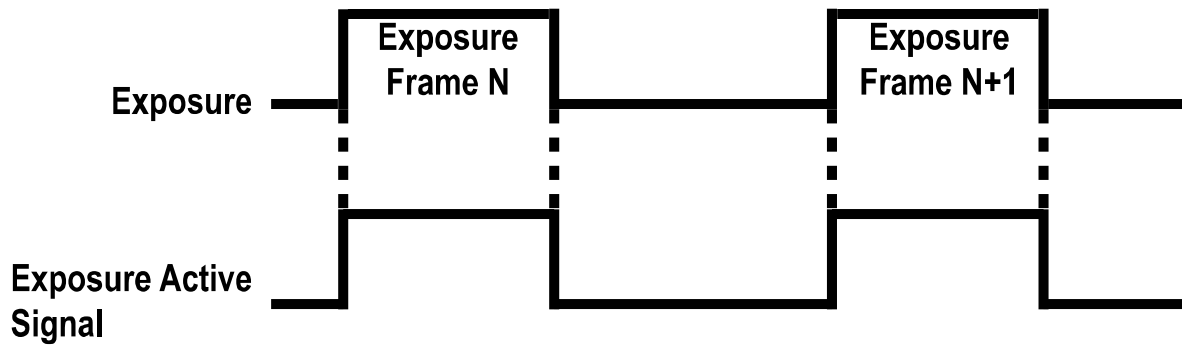

Figure 9-12 Exposure Active Signal



### Strobe

When the Line Source parameter is set to **Strobe** ('sinc 30'), the camera can output Strobe signals. Typically, the strobe signal goes high when the exposure time begins and goes low when the exposure time ends. This signal can be used as a flash trigger and is also useful when you are operating a system where either the camera or the object being imaged is movable. Typically, you do not want the camera to move during exposure. You can monitor the Strobe signal to know when exposure is taking place and thus know when to avoid moving the camera.

The VP-101MC/151MC cameras provide the Strobe signal as shown in the figure below. The Strobe signal goes high when the exposure time for the bottom line of pixels begins and goes low when the exposure time for the top line of pixels ends. The Strobe signal is only available when the exposure time is longer than the readout time and is useful when you are operating the camera under the flash lighting conditions.

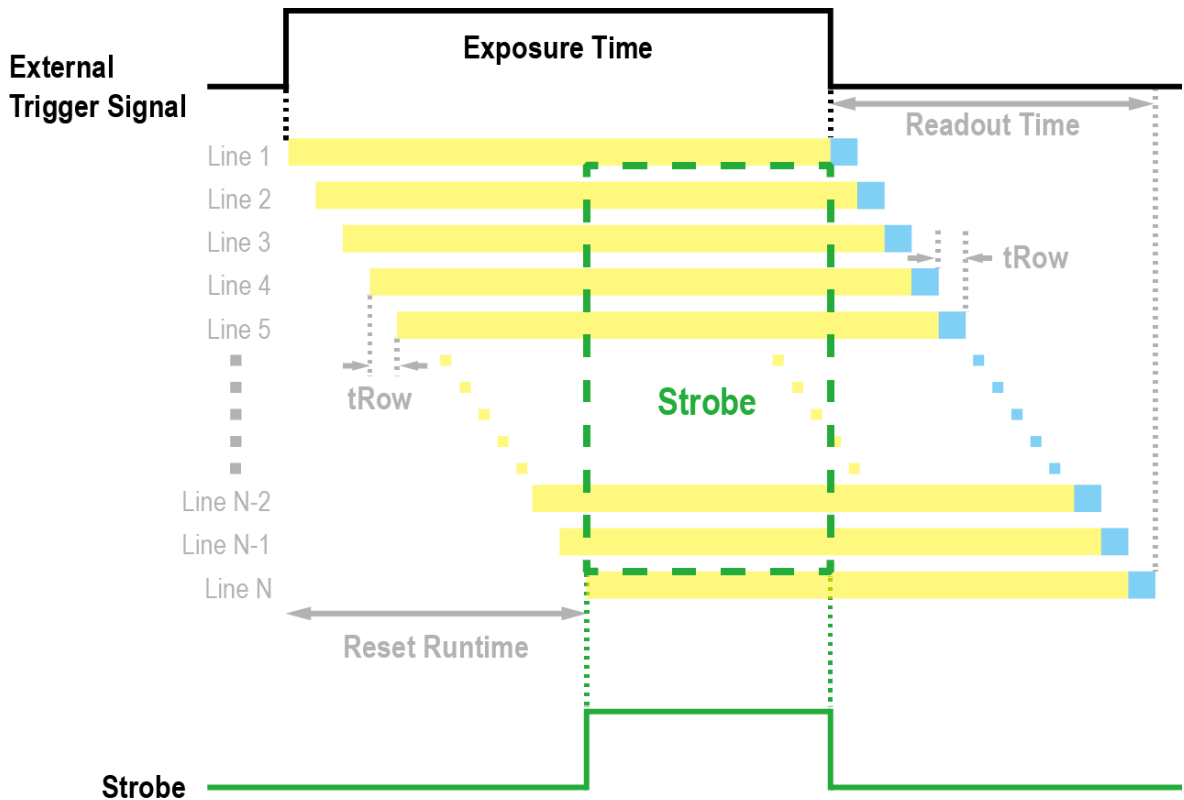

Figure 9-13 Strobe Signal

### Debounce

The Debounce feature of the VP-101MC/151MC cameras allows to supply only valid signals to the camera by discriminating between valid and invalid input signals. The Debounce Time parameter specifies the minimum time that an input signal must remain High or Low in order to be considered as a valid input signal. When you use the Debounce feature, be aware that there is a delay between the point where the valid input signal arrives and the point where the signal becomes effective. The duration of the delay is determined by the Debounce Time parameter setting value. When you set the Debounce Time parameter, High and Low signals shorter than the setting value are considered invalid and ignored as shown in the figure below.

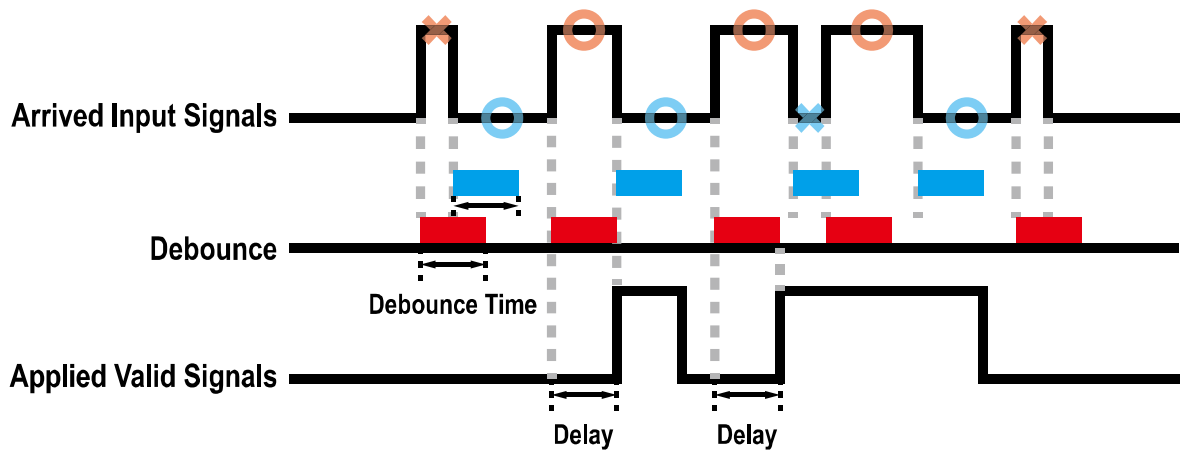

Figure 9-14 Debounce

The command related to Debounce Time is as follows.

Command	Value	Description
Debounce Time sdbt	0 – 1,000,000 $\mu$ s	Sets a Debounce Time in microseconds.

Table 9-18 Command related to Debounce Time

## 9.14 Timer Control

When the Line Source parameter is set to `Timer0Active`, the camera can provide output signals by using the Timer. On the VP-101MC/151MC cameras, the Frame Active, Exposure Active event, Strobe or external trigger signal is available as Timer source signal.

The commands related to Timer are as follows.

Command		Value	Description
Timer Duration	stdu	1 ~ 60,000,000 $\mu$ s	Sets the duration of the Timer output signal when the Timer Trigger Activation is set to Falling/Rising Edge.
Timer Delay	stdl	0 ~ 60,000,000 $\mu$ s	Sets the delay time to be applied before starting the Timer.
Timer Reset	-	-	Resets the Timer and starts it again.
Timer Trigger Source	stts	0: Off	Disables the Timer trigger.
		4: Frame Active	Sets the Timer to use a frame readout time as the source signal.
		6: Exposure Active	Sets the Timer to use the current exposure time as the source signal.
		22: Line0	Sets the Timer to use the external trigger signal as the source signal.
		30: Strobe	Sets the Timer to use the Strobe signal as the source signal.
Timer Trigger Activation	stta	0: Falling Edge	Specifies that a falling edge of the selected trigger signal will act as the Timer trigger.
		1: Rising Edge	Specifies that a rising edge of the selected trigger signal will act as the Timer trigger.
		2: Level Low	Specifies that the Timer output signal will be valid as long as the selected trigger signal is Low.
		3: Level High	Specifies that the Timer output signal will be valid as long as the selected trigger signal is High.

Table 9-19 Commands related to Timer Control

For example, when the Timer Trigger Source is set to Exposure Active and the Timer Trigger Activation is set to Level High, the Timer will act as follows:

1. When the source signals set by the Timer Trigger Source command are applied, the Timer will start operations.
2. The delay set by the Timer Delay command begins to expire.
3. When the delay expires, the Timer signal goes high as long as the source signal is high.

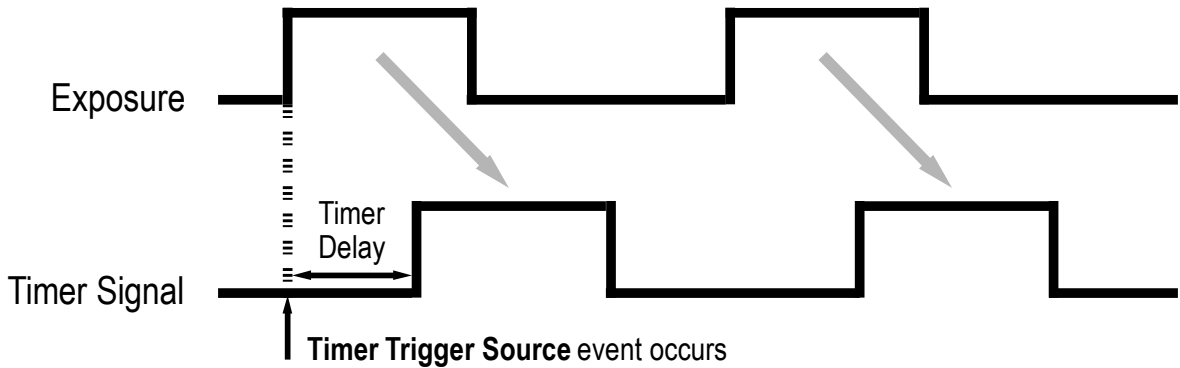

\* **Timer Trigger Activation** is set to **Level High**.

Figure 9-15 Timer Signal

### 9.15 TEC Control

A fan is installed on the rear panel of the camera to radiate heat. You can set the fan to turn on or off. You can also set the Thermoelectric Peltier to turn on when a specified internal temperature is reached.

The commands related to TEC Control are as follows.

Command	Value	Description
Target Temperature	stt -10°C ~ 80°C	Sets the temperature to operate the Thermoelectric Peltier when the Peltier Operation Mode is set to On.
Fan Operation Mode	sfm 0: Off 1: On	Turns off the fan. Turns on the fan.
Fan Speed	gfrpm -	Displays the current Fan RPM.
Peltier Operation Mode	sptm 0: Off 1: On	Turns off the Thermoelectric Peltier. Turns on the Thermoelectric Peltier when the internal temperature exceeds the value set in the Target Temperature.

Table 9-20 Commands related to TEC Control

## 9.16 Temperature Monitor

The camera has an embedded sensor chip to monitor the internal temperature.

The commands related to Device Temperature are as follows.

Command	Value	Description
Device Temperature    gct	-	Displays device temperature in Celsius.

Table 9-21 Command related to Device Temperature

## 9.17 Status LED

A LED is installed on the rear panel of the camera to inform the operation status of the camera.

LED status and corresponding camera status are as follows:

Status LED	Description
Steady Red	The camera is not initialized.
Fast Flashing Green	The camera is transmitting image data.

Table 9-22 Status LED

## 9.18 Test Image

To check whether the camera operates normally or not, it can be set to output test images generated in the camera, instead of the image data from the image sensor. Three types of test images are available; image with different value in horizontal direction (Test Image 1), image with different value in diagonal direction (Test Image 2), and moving image with different value in diagonal direction (Test Image 3).

The command related to Test Image is as follows.

Command		Value	Description
Test Image	sti	0: Off	Disables the Test Image feature.
		1: Test Image 1	Sets to Grey Horizontal Ramp.
		2: Test Image 2	Sets to Grey Diagonal Ramp.
		3: Test Image 3	Sets to Grey Diagonal Ramp Moving.
		16: Sensor Specific	Sets to the Test Image provided by the image sensor.

Table 9-23 Commands related to Test Image

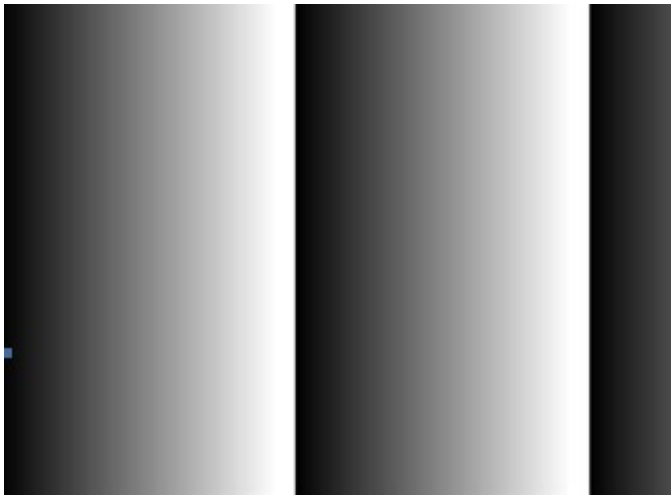

Figure 9-16 Test Image1

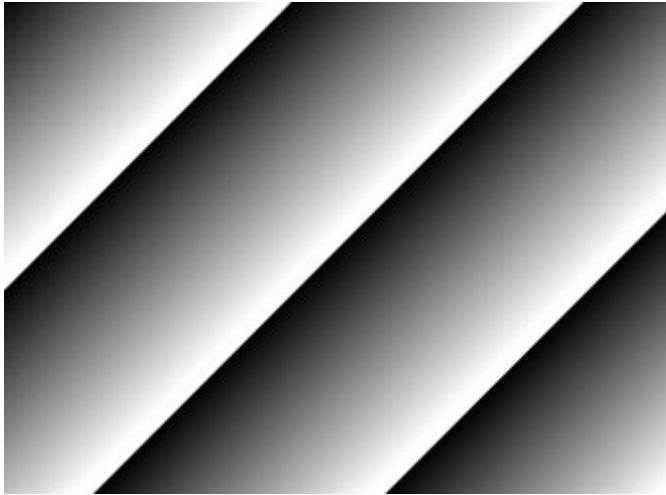

Figure 9-17 Test Image2



Figure 9-18 Test Image3



**Caution!**

The test pattern may look different because the region of the test image may vary depending on the camera's resolution.

---

## 9.19 Reverse X

The Reverse X feature lets you flip images horizontally. This feature is available in all operation modes of the camera. The command related to Reverse X is as follows.

Command	Value	Description
Reverse X	shf	0: FALSE
		1: TRUE

Table 9-24 Command related to Reverse X



Figure 9-19 Original Image

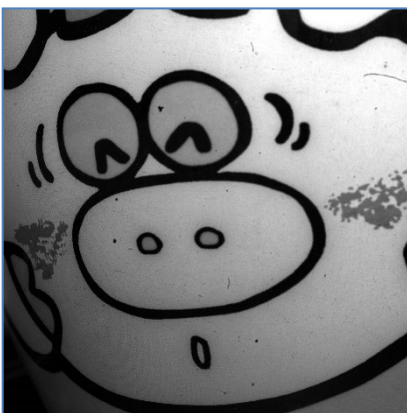

Figure 9-20 Reverse X Image



## 9.20 Device Reset

Resets the camera physically to power off and on.

The command related to Device Reset is as follows.

Command	Value	Description
Device Reset      rst	-	Resets the camera physically.

Table 9-25 Command related to Device Reset

## 9.21 Field Upgrade

The camera provides a feature to upgrade the Firmware and FPGA logic through the Camera Link interface rather than disassemble the camera in the field. Refer to **Appendix B** for more details about how to upgrade.

## Chapter 10. Camera Configuration

### 10.1 Setup Command

You can configure all camera settings via RS-644 serial interface of the Camera Link. When you want to control the camera using a terminal or access directly to the camera at your application, you need to set your network as follows:

- Baud Rate: 1152200 bps
- Data Bit: 8 bit
- Parity Bit: No parity
- Stop Bit: 1 stop bit
- Flow Control: None

All camera setting commands are transmitted in the ASCII command type except a command for transmitting a large file such as firmware download. All camera setting commands are transmitted from the user application, and then the camera returns a response ('OK', 'Error' or information) for a command. When you execute a write command, the camera returns a response to inform whether the command has been successfully executed. When you execute a read command, the camera returns an error or information.

```
Command format:  
<command> <parameter1> <parameter2> <cr>  
0 - 2 parameters follow the command.  
Response:  
If a write command is successfully executed  
OK <cr> <lf>
```

e.g., Write command

In response to a "set 100" command the camera will return (in hex value)

Command: 73 65 74 20 31 30 30 0D

set 100<cr>

```
Response:      73 65 74 20 31 30 30 0D 0A      4F 4B 0D 0A      3E
               set 100<cr><lf>                OK<cr><lf>        >
               Echo                             result         prompt
```

If a read command is successfully executed

<parameter1> <cr> <lf>

e.g., Read command

In response to a "get" command the camera will return (in hex value)

Command : 67 65 74 0D

get <cr>

```
Response :    67 65 74 0D 0A      31 30 30 0D 0A 3E
               get<cr><lf>        100<cr><lf>      >
               Echo                response          prompt
```

If a command is not executed successfully

Error: <Error code> <cr> <lf>

Prompt:

A prompt always follows the response. '>' is used as a prompt.

Types of Error Code

0x80000481: value of parameter is not valid.

0x80000482: the number of parameters is not matched.

0x80000484: command does not exist.

0x80000486: no permission to execute.

## 10.2 Actual Runtime of Commands

When you execute a command, the actual runtime of the command varies depending on the type of the command and the operating status of the camera.

All commands except Set Exposure Time ('set') command are applied to change the settings as illustrated below, on the rising edge of a REQ\_Frame signal before starting the readout process.

When you execute the 'set' command, the exposure time setting will be changed and applied at the starting of the exposure.

If you operate the camera with the Trigger Mode set to On, you must execute commands before applying the trigger signals in order to synchronize image outputs with the commands.

If you execute a command in the Free-Run mode, you may acquire up to two images that are not affected by the command execution. This is true because it is hard to verify the current operating status of the camera in the Free-Run mode.

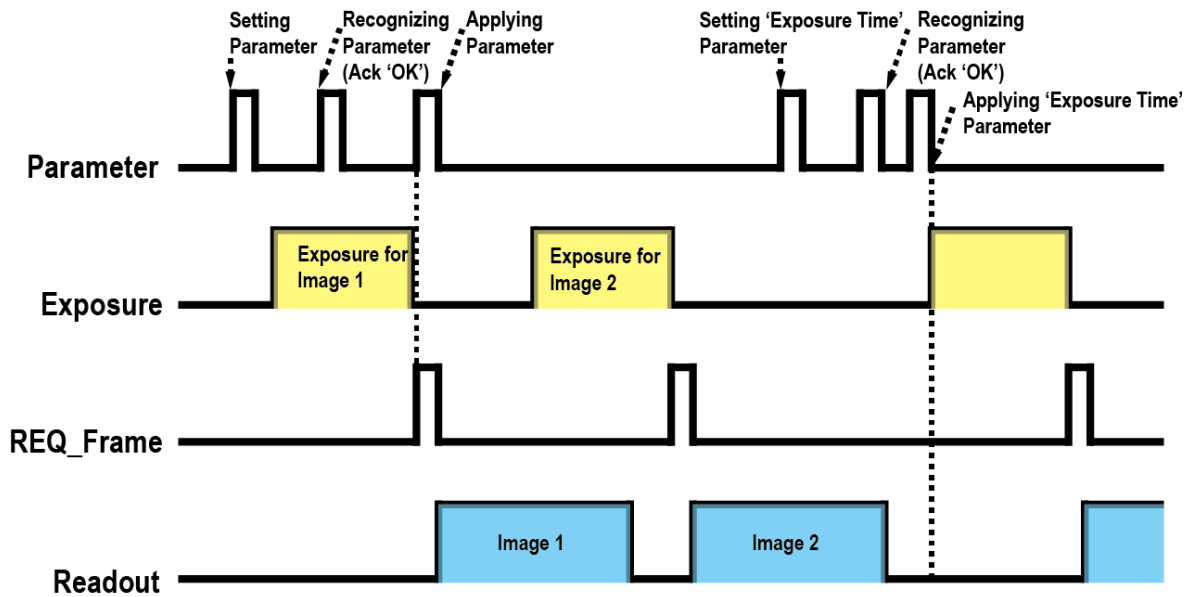

Figure 10-1 Actual Runtime of Commands

### 10.3 User Set Control

You can save the current camera settings to the camera's internal Flash memory. You can also load the camera settings from the camera's internal Flash memory. The camera provides two setups to save and three setups to load settings. The commands related to User Set Control are as follows.

Command		Value	Description
User Set Load	lcf	0: Default	Loads the Factory Default Setting to the camera.
		1: User 1 Setting	Loads the User 1 Setting to the camera.
		2: User 2 Setting	Loads the User 2 Setting to the camera.
User Set Save	sct	1: User 1 Setting	Saves the current camera settings to the User 1 Setting.
		2: User 2 Setting	Saves the current camera settings to the User 2 Setting.
User Set Default	sci	0: Default	Applies the Factory Default Setting when reset.
		1: User 1 Setting	Applies the User 1 Setting when reset.
		2: User 2 Setting	Applies the User 2 Setting when reset.

Table 10-1 Commands related to User Set Control

The camera settings stored in the Default can be loaded into the camera's workspace, but cannot be changed. The settings set in the workspace will be lost if the camera is reset or powered off. To use the current setting values in the workspace after a reset, you must save the settings to one of the user spaces.

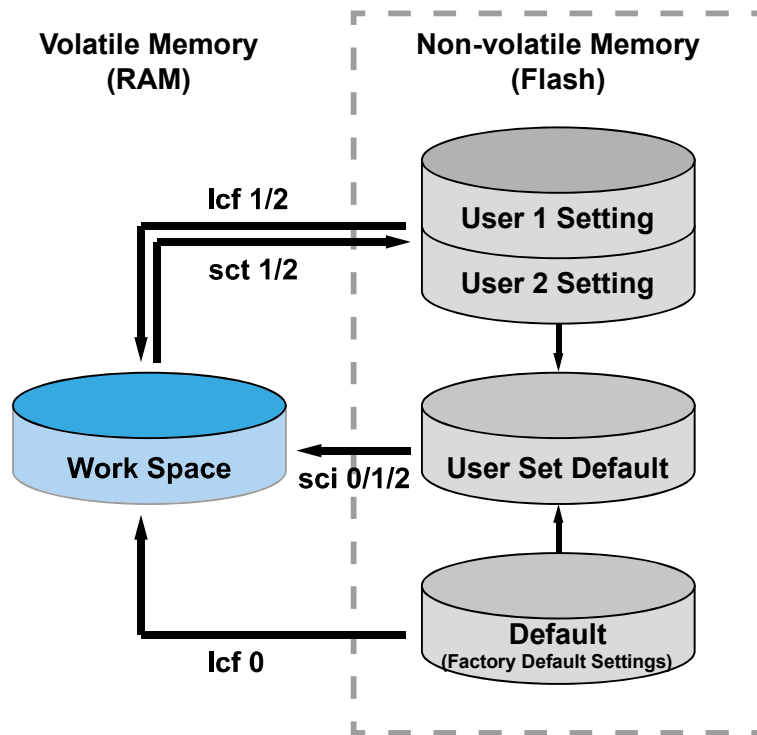

Figure 10-2 User Set Control

## 10.4 Sequencer Control

The Sequencer Control provided by the VP-101MC/151MC cameras allows you to apply different sets of parameter setting, called 'Sequencer Set', to a sequence of image acquisitions. As the camera acquires images, it applies one Sequencer Set after the other. This allows the camera to respond quickly to changing imaging requirements. For example, changes in illumination conditions influence the imaging requirements.

With the User Set Control feature, you can save user defined Sequencer Sets in the camera's non-volatile memory. Then after the camera is powered on or reset, the Sequencer Sets are available according to the User Set Default parameter. Each Sequencer Set is identified by an index number ranging from 0 to 31. Accordingly, you can define up to 32 different Sequencer Sets.

On the VP-101MC/151MC cameras, only the Flat Field correction data can be configured for Sequencer Sets. The commands related to Sequencer Control are as follows.

Command		Value	Description
Sequencer Mode	ssqm	0	Disables the Sequencer.
		1	Enables the Sequencer.
Sequencer Configuration Mode	ssqcm	0	Disables the Sequencer Configuration Mode.
		1	Enables the Sequencer Configuration Mode.
Sequencer Set Selector	ssqss	0 ~ 31	Selects an index number of a Sequencer Set to be configured.
Sequencer Set Active	qsqsa	-	Displays the index number of the Sequencer Set that is currently active (0 ~ 31).
Sequencer Set Count	ssqsc	1 ~ 32	Sets the number of Sequencer Sets to be applied.
Reset Sequencer	rsq	-	Returns to Sequencer Set 0.

Table 10-2 Commands related to Sequencer Control



### Caution!

To apply Sequencer Sets, you must set the Trigger Mode parameter to On ('stm 1').

### Use Case – Applying Four Different Flat Field Correction Data to Sequencer Sets

For example, assume that four different Flat Field correction data optimized for White, Green, Red and Blue pixels are applied to four different Sequencer Sets to inspect LCD panels.

1. Disables the Sequencer Mode ('ssqm 0').
2. Enables the Sequencer Configuration Mode ('ssqcm 1').
3. Set the Sequencer Set Selector parameter to 0 ('ssqss 0') and set the Flat Field Data Selector parameter to 0 ('sfd 0'). Then, set the Sequencer Set Selector parameter to 1, 2 and 3, and set the Flat Field Data Selector parameter to 1, 2 and 3 respectively.
4. Sets the Sequencer Set Count parameter to 4 ('ssqsc 4').
5. Disables the Sequencer Configuration Mode ('ssqcm 0'), and then enables the Sequencer Mode ('ssqm 1').

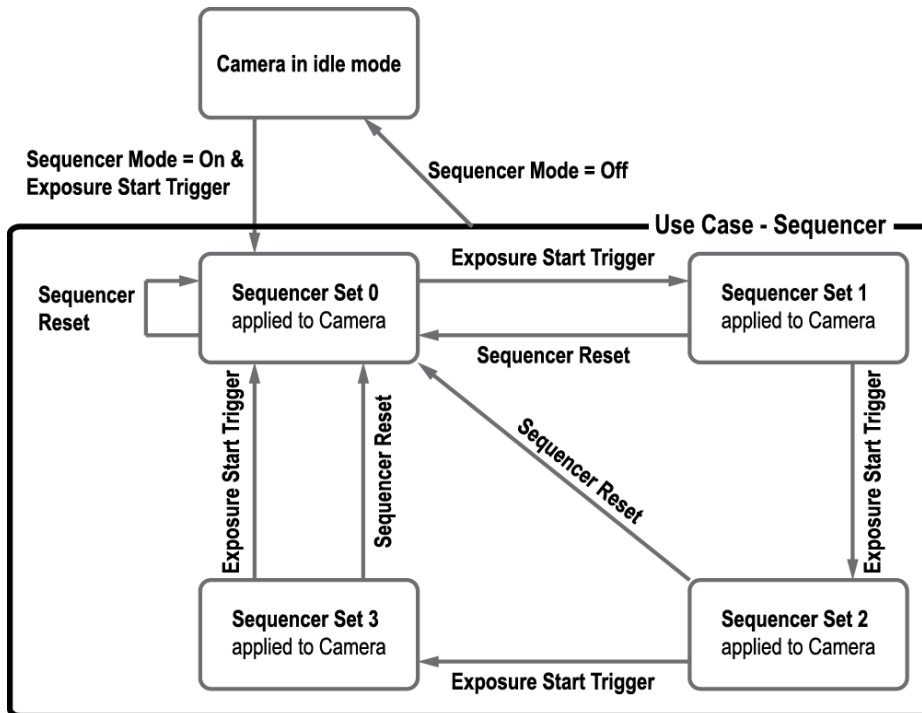

Figure 10-3 Sequencer Diagram (Use Case)



#### Note:

- You can save the user defined Sequencer Sets in the camera's non-volatile memory by using the User Set Control feature. For more information, refer to 10.3 User Set Control.
- Executing the Sequencer Reset command ('rsq') allows to return to the Sequencer Set 0 status at any time while cycling through the Sequencer.



## 10.5 Command List

You can set all features provided by the VP-101MC/151MC cameras by using the following commands.

Command	Syntax	Return Value	Description
Help	help	String	Displays a list of all commands.
Set ROI Offset X Get ROI Offset X	sox n gox	OK n	X coordinate of start point ROI n: X axis offset
Set ROI Offset Y Get ROI Offset Y	soy n goy	OK n	Y coordinate of start point ROI n: Y axis offset
Set Image Width Get Image Width	siw n giw	OK n	Sets a width of the Image ROI. n: Width value
Set Image Height Get Image Height	sih n gih	OK n	Sets a height of the Image ROI. n: Height value
Set Binning Selector Get Binning Selector	sbns 0 1 gbns	OK 0 1	Selects the Binning engine. 0: Sensor 1: Logic
Set Binning Horizontal Mode Get Binning Horizontal Mode	sbhm 0 1 gbhm	OK 0 1	Sets the Binning mode to apply to Binning Horizontal. 0: Sum 1: Average
Set Binning Horizontal Get Binning Horizontal	sbh 1 2 3 4 gbh	OK 1 2 3 4	The number of horizontal pixels to combine together. 1 2 3 4: ×1, ×2, ×3, ×4
Set Binning Vertical Mode Get Binning Vertical Mode	sbvm 0 1 gbvm	OK 0 1	Sets the Binning mode to apply to Binning Vertical. 0: Sum 1: Average
Set Binning Vertical Get Binning Vertical	sbv 1 2 3 4 gbv	OK 1 2 3 4	The number of vertical pixels to combine together. 1 2 3 4: ×1, ×2, ×3, ×4
Acquisition Start	ast	OK	Starts image acquisitions.
Acquisition Stop	asp	OK	Stops image acquisitions.

Table 10-3 Command List #1

Command	Syntax	Return Value	Description
Set Test Image Get Test Image	sti 0 1 2 3 16 gti	OK 0 1 2 3 16	Sets the Test Image. 0: Disables the Test Image feature. 1: Sets to Grey Horizontal Ramp. 2: Sets to Grey Diagonal Ramp. 3: Sets to Grey Diagonal Ramp Moving. 16: Sets to the Test Image provided by the image sensor.
Set Camera Link Tap Geometry Get Camera Link Tap Geometry	stg 2 4 8 10 gtg	OK 2 4 8 10	Sets the Camera Link Tap Geometry. 2: 1X2-1Y (2 Tap) 4: 1X4-1Y (4 Tap) 8: 1X8-1Y (8 Tap) 10: 1X10-1Y (10 Tap)
Set Data Bit Get Data Bit	sdb 8 10 12 gdb	OK 8 10 12	Sets the Pixel Format. 8: 8 bit 10: 10 bit 12: 12 bit
Set Camera Link Clock Selector Get Camera Link Clock Selector	sccs 0 1 gccs	OK 0 1	Sets the Camera Link Pixel Clock speed. 0: 85 MHz 1: 65 MHz
Set Defect Correction Get Defect Correction	sdc 0 1 gdc	OK 0 1	Sets the Defect Pixel Correction. 0: Disables the Defect Pixel Correction. 1: Enables the Defect Pixel Correction.
Set Horizontal Flip Get Horizontal Flip	shf 0 1 ghf	OK 0 1	Sets the Reverse X (Horizontal Flip). 0: Disables the Reverse X. 1: Enables the Reverse X.

Table 10-4 Command List #2

Command	Syntax	Return Value	Description
Set Trigger Mode Get Trigger Mode	stm 0 1 gtm	OK 0 1	Sets the Trigger Mode. 0: Trigger Mode Off (Free run mode) 1: Trigger Mode On
Set Exposure Mode Get Exposure Mode	sem/ses 0 1 gem/ges	OK 0 1	Sets the Exposure mode. 0: Timed 1: Trigger Width
Set Trigger Source Get Trigger Source	sts 3 10 14 18 22 gts	OK 3 10 14 18 22	Specifies a source signal when the Trigger Mode is set to On. 3: Software 10: User Output0 14: CC1 18: Timer0 Active 22: Line0
Generate SW Trigger	nst	OK	Generates a Software trigger signal.
Set Trigger Activation Get Trigger Activation	sta 0 1 gta	OK 0 1	Sets the activation mode for the selected source signal when the Trigger Mode is set to On. 0: Falling Edge 1: Rising Edge
Set Exposure Time Get Exposure Time	set n get	OK n	Sets an exposure time. n: Exposure time in microseconds (Setting range: 1 – 60,000,000 $\mu$ s)
Set Frame Rate Get Frame Rate	sfr n gfr	OK n	Sets the rate at which the exposure start trigger will be generated when the Trigger Mode is set to Off.
Set Black Level Get Black Level	sbl n gbl	OK n	Sets the black level value. n: Black Level (Setting range: 0 ~ 255)
Set Digital Gain Get Digital Gain	sdg n gdg	OK n	Sets the digital gain value. n: Gain (Setting range: 1 $\times$ ~ 32 $\times$ )

Table 10-5 Command List #3

Command	Syntax	Return Value	Description
Generate Flat Field Data	gfd none   0   n	OK	Executes the Flat Field Generator. none / 0: Auto-adjusts the target value of the image after correction. n: Manually sets the target value of the image after correction (1 - 4095 @ 12 bit).
Set Flat Field Data Selector Get Flat Field Data Selector	sfd 0   1   ...   15 gfd	OK 0   1   ...   15	Selects a Flat Field correction data location. 0 ~ 15: User defined locations
Save Flat Field Data	sfd	OK	Saves the generated Flat Field correction data in the selected FFC data location.
Load Flat Field Data	lfd	OK	Loads the FFC data from the non-volatile memory into the volatile memory.
Set Flat Field Correction Get Flat Field Correction	sfc 0   1 gfc	OK 0   1	Sets the Flat Field Correction feature. 0: Disables the Flat Field Correction. 1: Enables the Flat Field Correction.
Set Point DSNU Correction Get Point DSNU Correction	sdsnp 0   1 gdsnp	OK 0   1	Sets the Hot Pixel Correction feature. 0: Disables the Hot Pixel Correction. 1: Enables the Hot Pixel Correction.
Set Fan Mode Get Fan Mode	sfm 0   1 gfm	OK 0   1	Sets the Fan operation mode. 0: Fan Off 1: Fan On
Set Peltier Operation Mode Get Peltier Operation Mode	sptm 0   1 gptm	OK 0   1	Sets the Peltier operation mode. 0: Peltier Off 1: Peltier On
Set Target Temperature Get Target Temperature	stt n gtt	OK n	Sets the temperature to operate the fan when the Peltier Operation Mode is set to Temperature. n: -10°C ~ 80°C

Table 10-6 Command List #4

Command	Syntax	Return Value	Description
Set Line Source Get Line Source	slnc 0 4 6 10 18 30 glnc	OK 0 4 6 10 18 30	Specifies a source signal for the control I/O receptacle. 0: Disables the Line input/output. 4: Frame Active 6: Exposure Active 10: User Output0 18: Timer0 Active 30: Strobe
Set Line Inverter Get Line Inverter	slni 0 1 glni	OK 0 1	Sets whether to invert the line output. 0: Disables inversion on the line output. 1: Enables inversion on the line output.
Set User Output Value Get User Output Value	suov 0 1 guov	OK 0 1	Sets the User Output value. 0: Sets the bit state of the line to Low. 1: Sets the bit state of the line to High.
Set Timer Trigger Source Get Timer Trigger Source	stts 0 4 6 22 30 gtts	OK 0 4 6 22 30	Specifies the source signal for the Timer output signal. 0: Disables the Timer trigger. 4: Frame Active 6: Exposure Active 22: Line0 30: Strobe
Set Timer Duration Get Timer Duration	stdu n gtdu	OK n	Sets the duration of the Timer output signal. n: 1 – 60,000,000 $\mu$ s
Set Timer Delay Get Timer Delay	stdl n gtdl	OK n	Sets the delay time for the Timer. n: 0 – 60,000,000 $\mu$ s
Set Timer Trigger Activation Get Timer Trigger Activation	stta 0 1 2 3 gtta	OK 0 1 2 3	Sets the activation mode for the Timer. 0: Falling Edge 1: Rising Edge 2: Level Low 3: Level High
Set Debounce Time Get Debounce Time	sdbt n gdbt	OK n	Sets the Debounce time. n: Debounce time in microseconds (0 – 1,000,000 $\mu$ s)

Table 10-7 Command List #5

Command	Syntax	Return Value	Description
Set Sequencer Mode Get Sequencer Mode	ssqm 0 1 gsqm	OK 0 1	Sets the Sequencer mode. 0: Disables the Sequencer Mode. 1: Enables the Sequencer Mode.
Set Sequencer Config. Mode Get Sequencer Config. Mode	ssqcm 0 1 gsqcm	OK 0 1	Sets the Sequencer Configuration mode. 0: Disables the Sequencer Configuration mode. 1: Enables the Sequencer Configuration mode.
Set Sequencer Set Selector Get Sequencer Set Selector	ssqss n gsqss	OK n	Selects an index number of a Sequencer Set to be configured. n: Sequencer Set index number (0 ~ 31)
Set Sequencer Set Count Get Sequencer Set Count	ssqsc n gsqsc	OK n	Sets the number of Sequencer Sets to be applied. n: 1 ~ 32
Get Sequencer Set Active	gsqsa	n	Displays the index number of the Sequencer Set that is currently active. n: 0 ~ 31
Reset Sequencer	rsq	OK	Returns to Sequencer Set 0.
Set AWB Offset X Get AWB Offset X	swx n gwx	OK n	Sets a horizontal offset from the origin to the AWB ROI.
Set AWB Offset Y Get AWB Offset Y	swy n gwy	OK n	Sets the vertical offset from the origin to the AWB ROI.
Set AWB Width Get AWB Width	sww n gww	OK n	Sets a width for the AWB ROI.
Set AWB Height Get AWB Height	swh n gwh	OK n	Sets a height for the AWB ROI.
Set RGB Gain Get RGB Gain	srg r g b g grg r g b	OK g	Sets the intensity of color pixels. r g b: Red / Green / Blue pixels g: Gain value (1.0× ~ 4.0×)
Auto White Balance	arg	OK	Automatically adjusts the white balance once.

Table 10-8 Command List #6

Command	Syntax	Return Value	Description
Set Dynamic DPC Get Dynamic DPC	sddc 0 1 gddc	OK 0 1	Sets the Dynamic DPC feature. 0: Dynamic DPC Off 1: Enables the Dynamic DPC feature.
Set + Defective Pixel Offset Threshold Get + Defective Pixel Offset Threshold	shpo n ghpo	OK n	Sets the + Threshold Offset value of the Median filter (0 ~ 2048 at 12 bit).
Set - Defective Pixel Offset Threshold Get - Defective Pixel Offset Threshold	scpo n gcpo	OK n	Sets the - Threshold Offset value of the Median filter (0 ~ 2048 at 12 bit).
Load Config. From	lcf 0 1 2	OK	Loads the camera setting values. 0: Loads the Factory Default Setting. 1: Loads the User 1 Setting. 2: Loads the User 2 Setting.
Save Config. To	sct 1 2	OK	Saves the current camera setting values. 1: Saves to the User 1 Setting. 2: Saves to the User 2 Setting.
Set Config. Initialization Get Config. Initialization	sci 0 1 2 gci	OK 0 1 2	Specifies setting values to be loaded when reset. 0: Factory Default Setting 1: User 1 Setting 2: User 2 Setting
Get Model Name	gmn	String	Displays the camera model name.
Get MCU Version	gmv	String	Displays the version of the camera MCU.
Get FPGA Version	gfv	String	Displays the version of the camera FPGA.
Get Serial Number	gsn piece	String	Displays the serial number of the camera.
Get Current Temperature	gct	String	Displays device temperature in Celsius.
Get Fan RPM	gfrpm	String	Displays the Fan RPM.
Reset Hardware	rst	-	Resets the camera physically to power off and on.

Table 10-9 Command List #7

## Chapter 11. Configurator GUI

The Configurator, a sample application, is provided to control the VP-101MC/151MC cameras. The Configurator provides an easy-to-use Graphic User Interface (GUI) that allows users to view and change the camera's settings mentioned in the previous chapters.

### 11.1 Camera Scan

When you execute the Configurator.exe file while the camera is powered on, the Camera Scan window appears as shown in the figure below. At that point, the Configurator checks serial ports of your computer and DLL provided by the Camera Link to scan whether a camera is connected. If the Configurator finds a connected camera, it displays the model name of the camera on the Camera Scan window. Double-clicking the model name of the camera displayed on the window will launch the Configurator and display the current parameter settings of the camera connected.

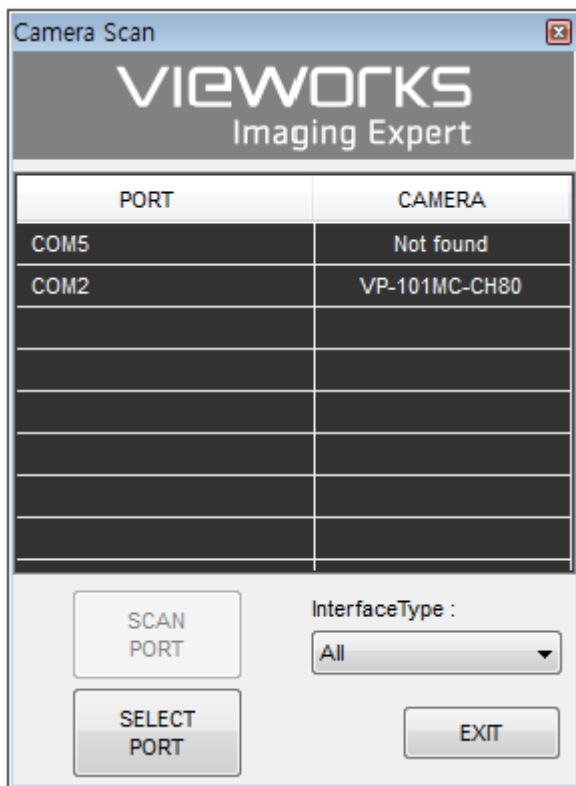

Figure 11-1 Configurator Loading Window



## 11.2 Menu

The menu bar of the Configurator provides the File, Start-Up, Tool, Acquisition and About menus.

### 11.2.1 File

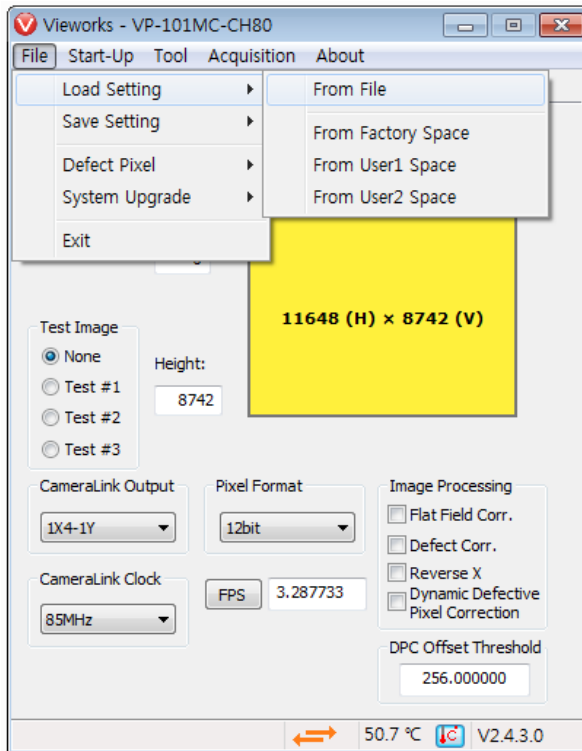

Figure 11-2 File Menu

- Load Setting:** Loads the camera setting values from the camera memory (Factory, User1 or User2) or user's computer.
- Save Setting:** Saves the camera setting values to the camera memory (User1 or User2) or user's computer (File).
- Defect Pixel:** Downloads defect information to the camera (Download to Camera) or uploads defect information stored in the camera to user's computer (Upload to PC).
- System Upgrade:** Upgrades the MCU or FPGA logic. The System Upgrade menu will be deactivated after executing the Acquisition Start command ('ast'). To activate the System Upgrade menu, execute the Acquisition Stop command ('asp').
- Exit:** Exits the Configurator.

## 11.2.2 Start-Up

The Start-Up menu allows you to select the camera setting values to be loaded when the camera is powered on.

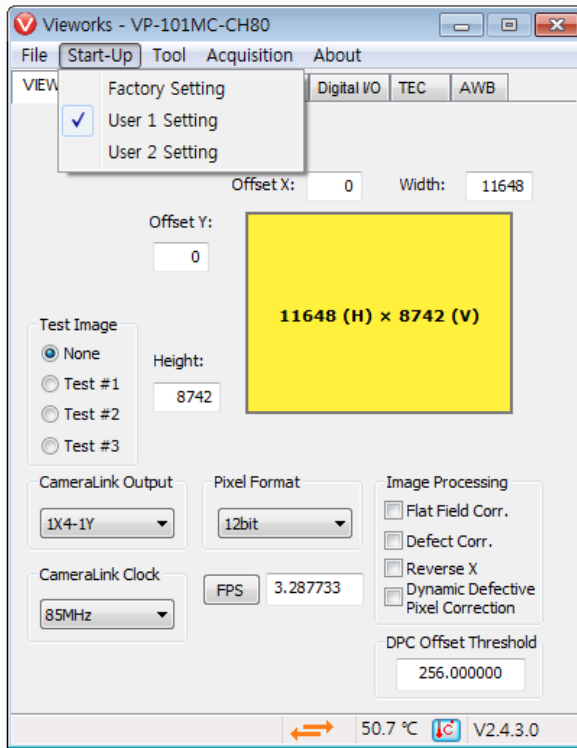

Figure 11-3 Start-Up Menu

- Factory Setting: Loads the camera setting values from the Factory space when the camera is powered on.
- User 1 Setting: Loads the camera setting values from the User1 space when the camera is powered on.
- User 2 Setting: Loads the camera setting values from the User2 space when the camera is powered on.

### 11.2.3 Tool

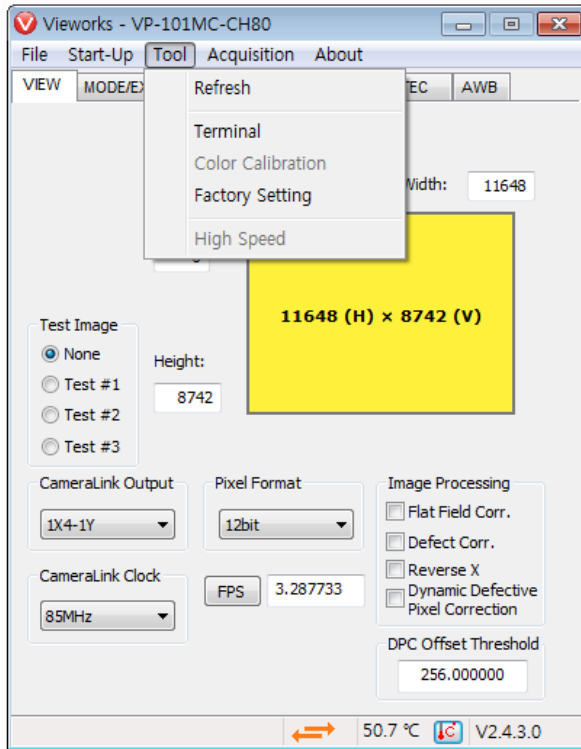

Figure 11-4 Tool Menu

Refresh:	Loads and displays the current camera setting values on the Configurator.
Terminal:	Displays the Terminal window. The Terminal window displays a user command for the feature that you have set on the Configurator. To hide the Terminal window, uncheck Terminal by clicking it again.
Color Calibration:	Not supported on the VP-101MC/151MC cameras.
Factory Setting:	Not supported for users.
High Speed:	Not supported on the VP-101MC/151MC cameras.

## 11.2.4 Acquisition

The Acquisition menu allows you to execute the Acquisition Start and Acquisition Stop commands.

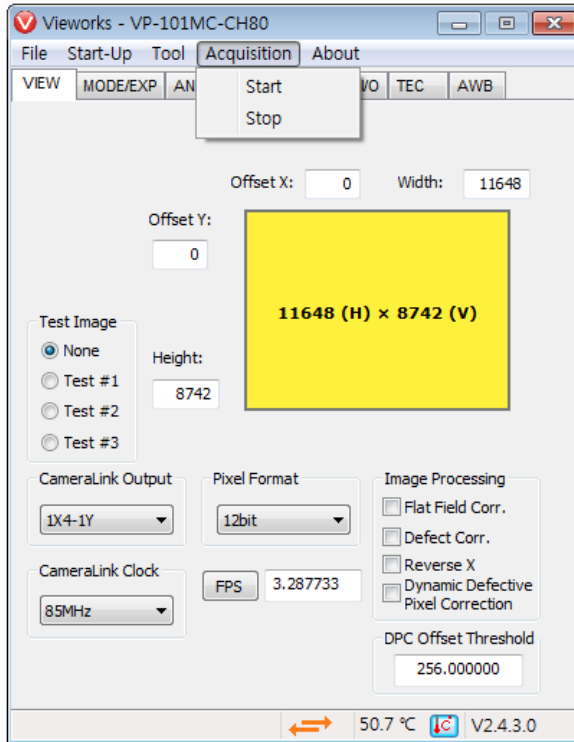

Figure 11-5 Acquisition Menu

**Start:** Executes the Acquisition Start command.

**Stop:** Executes the Acquisition Stop command.

### 11.2.5 About

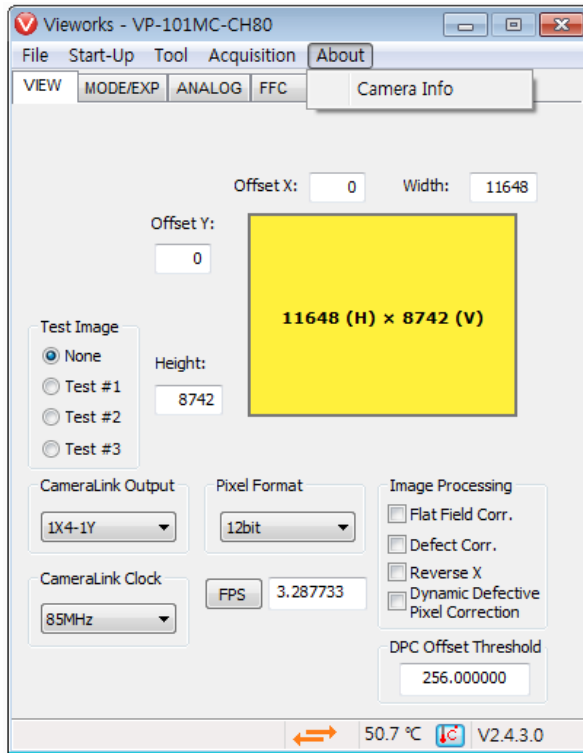

Figure 11-6 About Menu

Camera Info: Displays camera information (model name, serial number, version, etc.).

## 11.3 Tab

### 11.3.1 VIEW Tab

The VIEW tab allows you to set the camera's Image Region of Interest (ROI), Test Image mode, Camera Link Tap Geometry, Camera Link Pixel Clock Speed, Pixel Format and Image Processing.

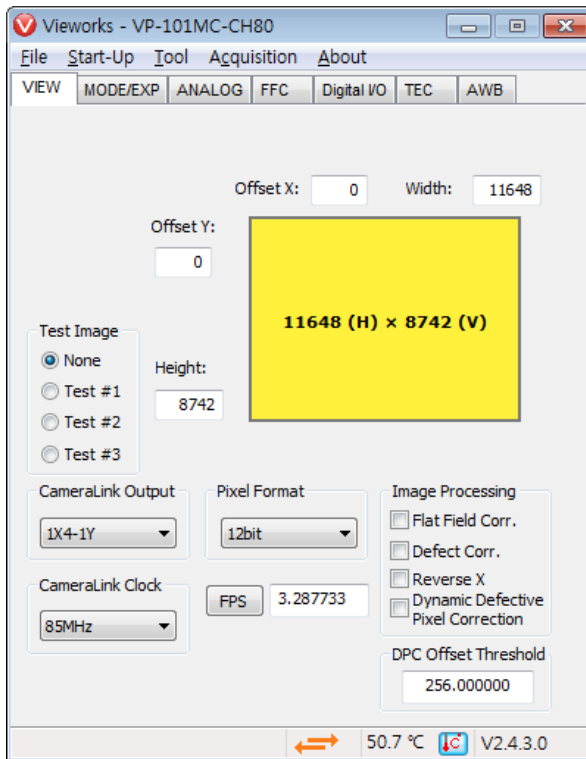

Figure 11-7 VIEW Tab

Offset X, Offset Y, Width Height: Sets the camera's Image ROI.

Test Image: Selects whether to apply the test image and a type of test images.

Camera Link Output: Sets the Camera Link Tap Geometry.

Camera Link Clock: Selects a Camera Link Pixel Clock speed.

Pixel Format: Selects a bit depth of data output.

FPS: Displays the current frame rate of the camera.

Image Processing: Enables or disables the Flat Field Correction, Defect Pixel Correction, Reverse X and/or Dynamic DPC features.

DPC Offset Threshold: Sets the Threshold Offset values of the Median filter.

### 11.3.2 MODE/EXP Tab

The MODE/EXP tab allows you to configure the camera's trigger mode and exposure time.

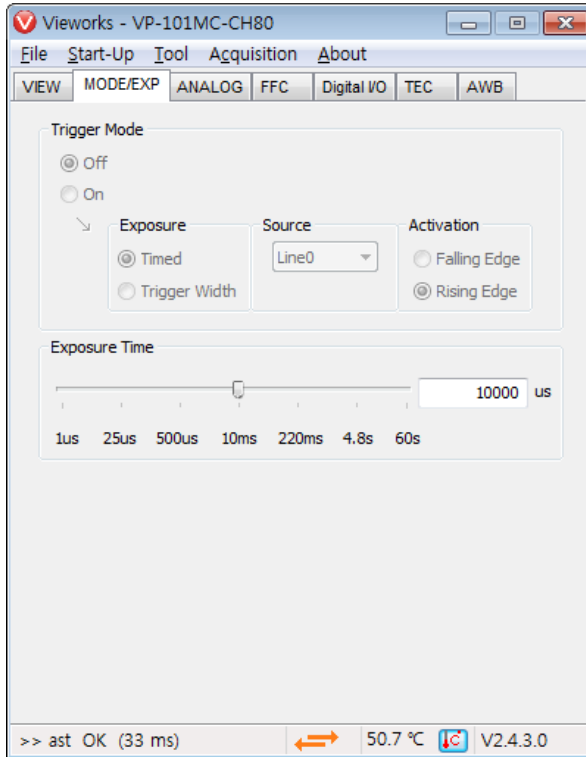

Figure 11-8 MODE/EXP Tab

Trigger Mode:	Sets the Trigger Mode. When you set the Trigger Mode to On, all associated options will be activated.
Exposure:	Selects an exposure mode.
Source:	Specifies a source signal for exposure triggering.
Activation:	Sets the activation mode for the trigger.
Exposure Time:	Sets an exposure time when the Trigger Mode is set to Off or when the Exposure is set to Timed.

### 11.3.3 ANALOG Tab

The ANALOG tab allows you to adjust the camera's gain and black level values.

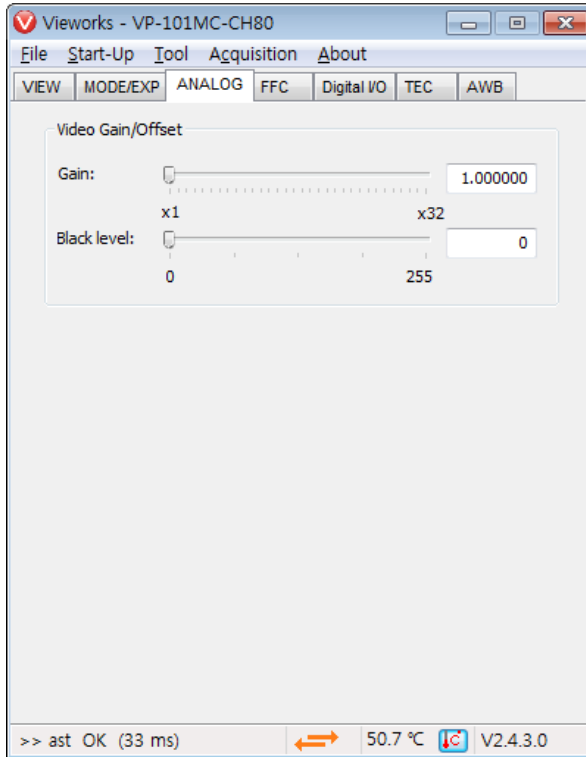

Figure 11-9 ANALOG Tab

Gain: Sets a gain value.

Black Level: Sets a black level value.



### 11.3.4 FFC Tab

The FFC tab allows you to set the Flat Field Correction feature.

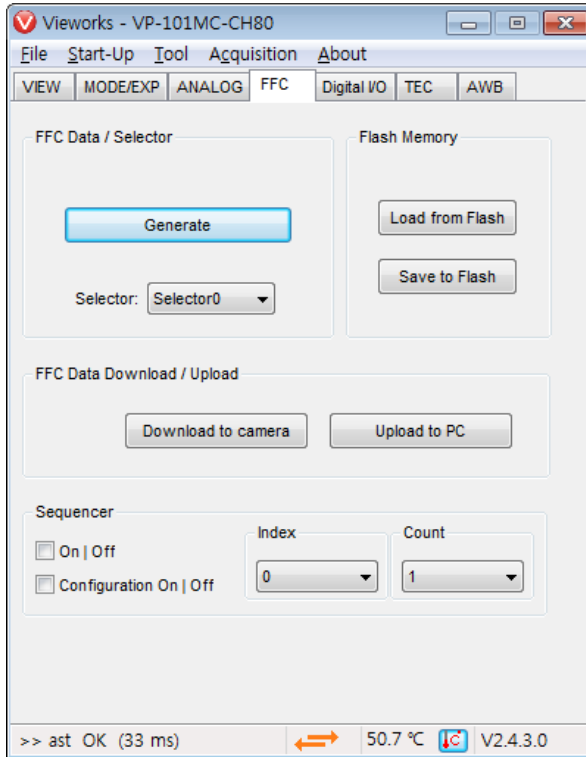

Figure 11-10 FFC Tab

Generate:	Generates the Flat Field correction data.
Selector:	Selects a location to save Flat Field correction data to or load Flat Field correction data from.
Flash Memory:	Saves the generated Flat Field correction data in the Flash memory (Save to Flash) for future use or loads the Flat Field correction data stored in the Flash memory (Load from Flash).
FFC Data Download / Upload:	Downloads the Flat Field correction data stored in user's computer to the camera (Download to camera) or uploads the Flat Field correction data stored in the camera to user's computer (Upload to PC).
Sequencer:	Sets the Sequencer feature. Sets the Sequencer Configuration mode, selects a Sequencer Set and/or sets the number of Sequencer Sets to be applied.

### 11.3.5 Digital I/O Tab

The control I/O receptacle of the VP-101MC and VP-151MC cameras can be operated in various modes. The Digital I/O tab allows you to configure the mode of the control I/O receptacle.

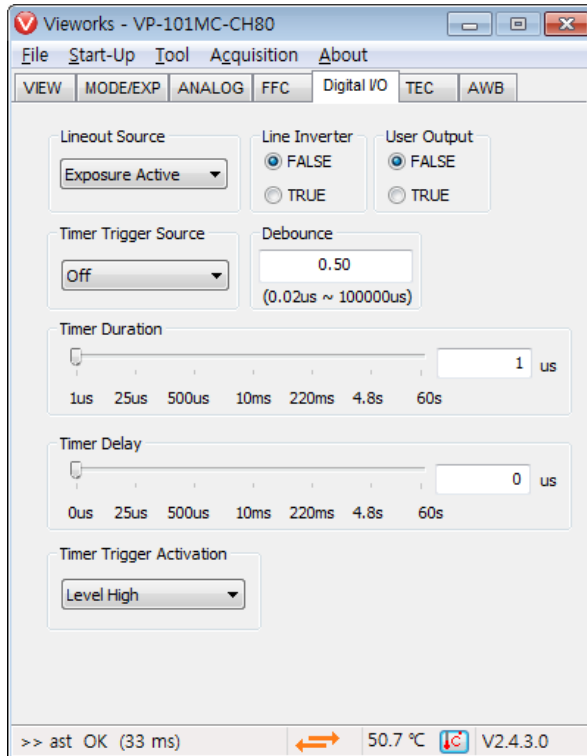

Figure 11-11 Digital I/O Tab

Lineout Source:	Specifies a source signal for the line output.
Line Inverter:	Sets whether to invert the line output signal.
User Output:	Sets the User Output value.
Timer Trigger Source:	Specifies a source signal for the Timer output.
Debounce:	Sets the Debounce time in microseconds.
Timer Duration:	Sets the duration of the Timer output signal.
Timer Delay:	Sets the delay time to be applied before starting the Timer output.
Timer Trigger Activation:	Sets the activation mode for the Timer output.

### 11.3.6 TEC Tab

The TEC tab allows you to set the operation mode of the fan and Thermoelectric Peltier. You can also set the target temperature for the operation of Thermoelectric Peltier.

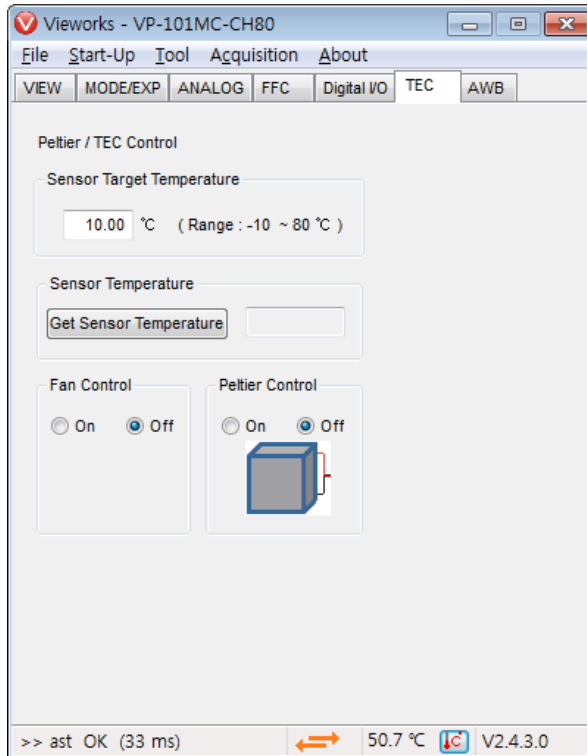

Figure 11-12 TEC Tab

Sensor Target Temperature:	Sets the image sensor's target temperature.
Sensor Temperature:	Displays the current temperature of the image sensor.
Fan Control:	Sets the fan operation mode.
Peltier Control:	Sets the Peltier operation mode.

### 11.3.7 AWB Tab (Color Camera Only)

The VP-101MC/151MC cameras provide the Auto White Balance feature. The AWB tab allows you to set the AWB ROI or adjust the white balance.

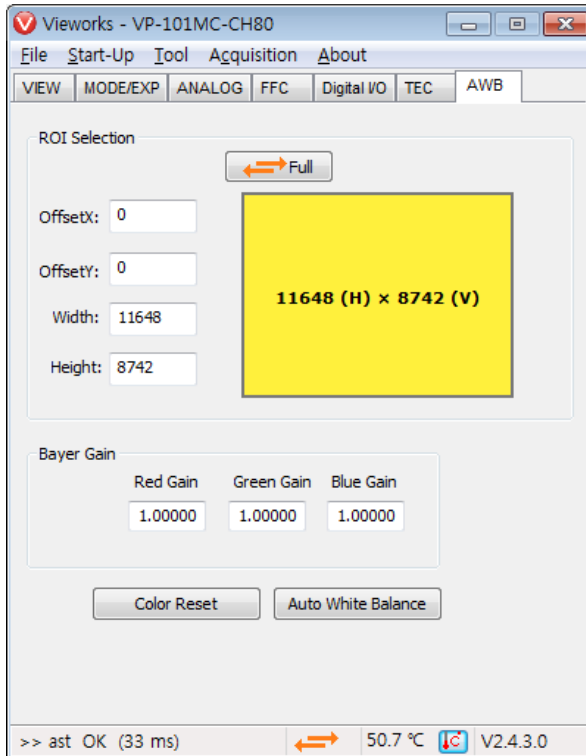

Figure 11-13 AWB Tab (Color Camera Only)

Offset X, Offset Y, Width, Height:	Sets a ROI for the Auto White Balance.
Bayer Gain:	Adjusts gain values for the Red, Green and Blue pixels.
Color Reset:	Resets gain values for the Red, Green and Blue pixels.
Auto White Balance:	Automatically adjusts the white balance once.

## Chapter 12. Troubleshooting

When you have a problem with a Vieworks camera, please check the following:

- If no image is displayed on your computer,
  - Ensure that all the cable connections are secure.
  - Ensure that the power supply is properly connected.
  - Ensure that trigger signals are applied correctly when you operate the camera with trigger signals.
- If images are not clear,
  - Ensure the camera lens or glass is clean.
  - Check the lens aperture is adjusted properly.
- If images are dark,
  - Ensure the camera lens is not blocked.
  - Check the exposure time is set properly.
  - Check the aperture is opened properly.
  - Check the Gain value is not set to small.
- If you identify abnormal operation or overheating sign,
  - Ensure the power supply is properly connected.
  - Stop using the camera when you notice smoke or abnormal overheating.
- If you have a problem using the Trigger Mode,
  - Ensure that the Software trigger related parameters are configured correctly.
  - Ensure that the trigger related parameters on you CC1 Frame Grabber are configured correctly when you set the Trigger Source parameter to CC1.
  - Ensure that cable connections are secure when you set the Trigger Source parameter to Line0.
- If there is communication failure between the camera and computer,
  - Ensure coax cables are connected properly.
  - Ensure that you have configured a Camera Link Frame Grabber in your computer correctly and the camera is connected properly to the Camera Link Frame Grabber.



## Appendix A. Defective Pixel Map Download

1. Create the Defective Pixel Map data in Microsoft Excel format as shown in the left picture below and save as a CSV file (\*.csv). The picture in the right shows the created Excel file opened in Notepad. The following rules need to be applied when creating the file.

Lines beginning with ':' or '--' are treated as notes.

You must enter the horizontal value first and then vertical value for coordinates of each defect pixel.

Coordinate values for each pixel can be placed in any order.

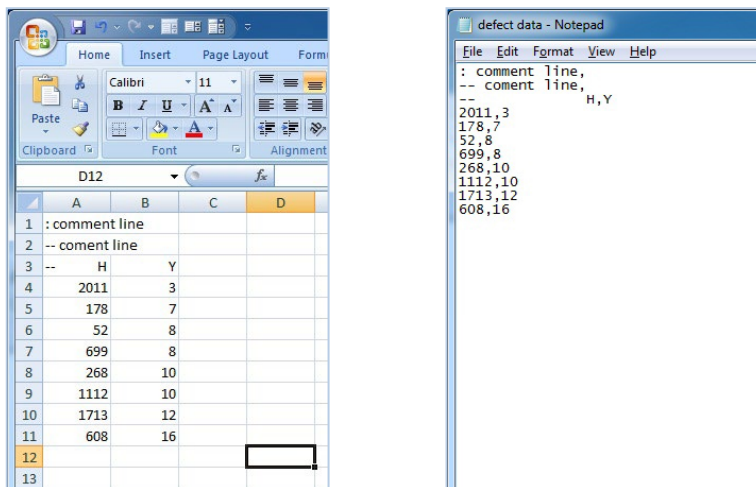

2. Select File > Defect Pixel > Download to Camera in the Configurator.

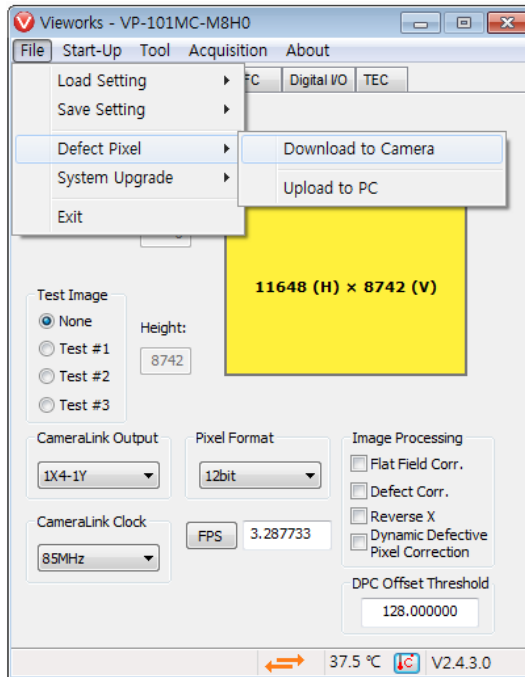

3. Search and select the created file, and then click Open.

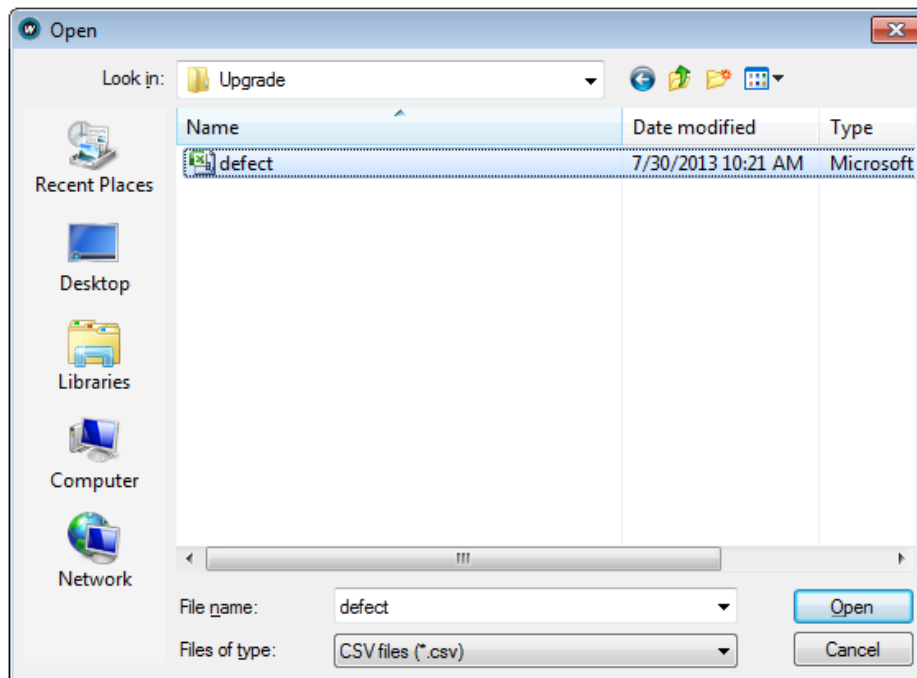



- The Configurator starts downloading Defective Pixel Map to the camera and the downloading status is displayed at the bottom of the window.

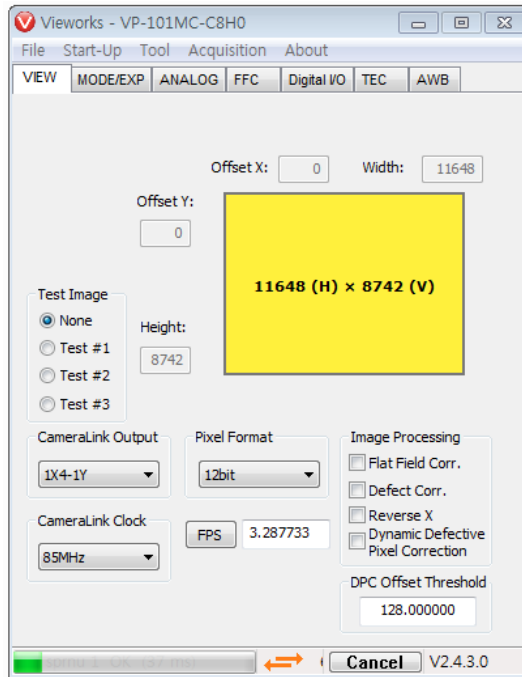

- Once the download is complete, the saving process will begin. During the saving process, make sure not to disconnect the power cord.

6. Once all the processes are complete, the Download completed message will appear at the bottom of the window.

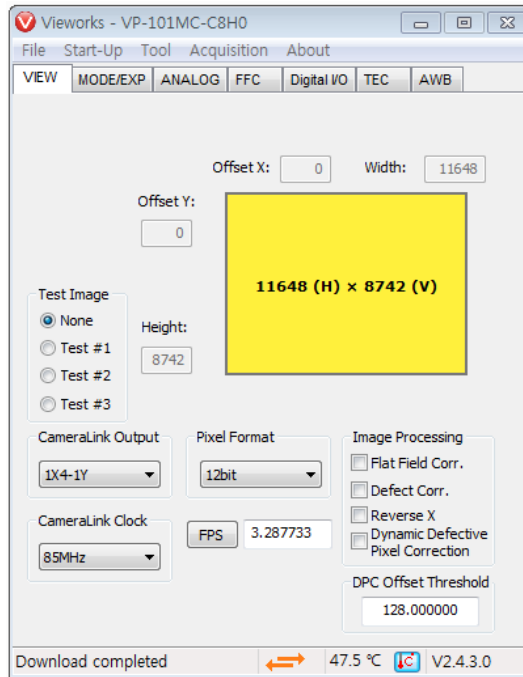

## Appendix B. Field Upgrade

You can upgrade the MCU and FPGA of the camera by following the procedures below. After executing the Acquisition Start command ('ast'), the System Upgrade menu will be deactivated. To activate the System Upgrade menu, execute the Acquisition Stop command ('asp').

1. Select File > System Upgrade > Package Upgrade in the Configurator.

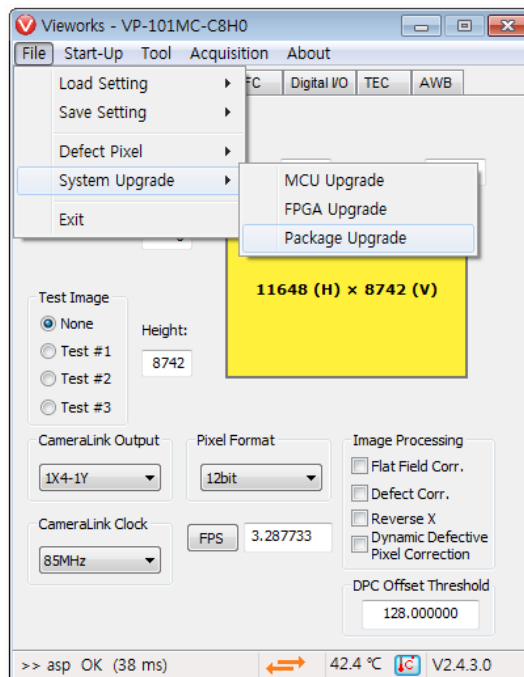

2. Search and select the provided MCU or FPGA file and then click Open.

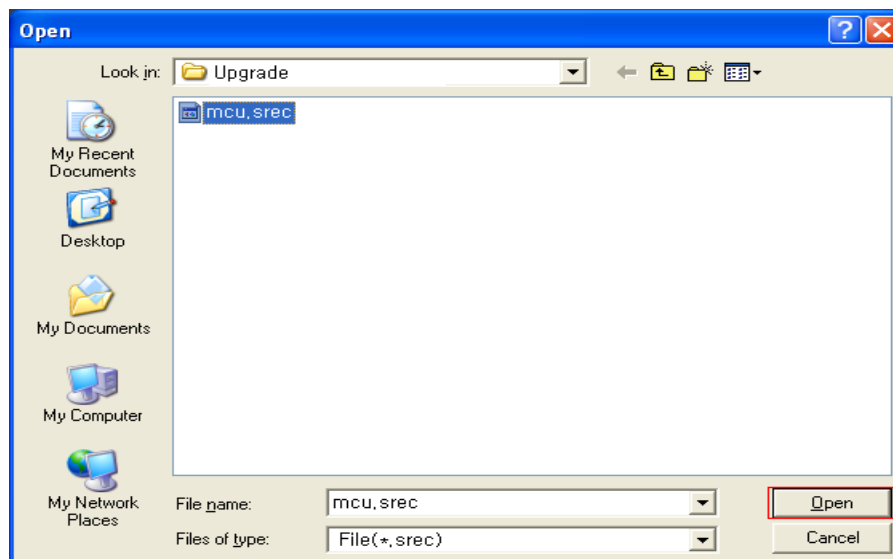

3. The camera begins downloading the upgrade file and the downloading status is displayed at the bottom of the window. This process may require several minutes to complete. If you want to cancel, click Cancel.

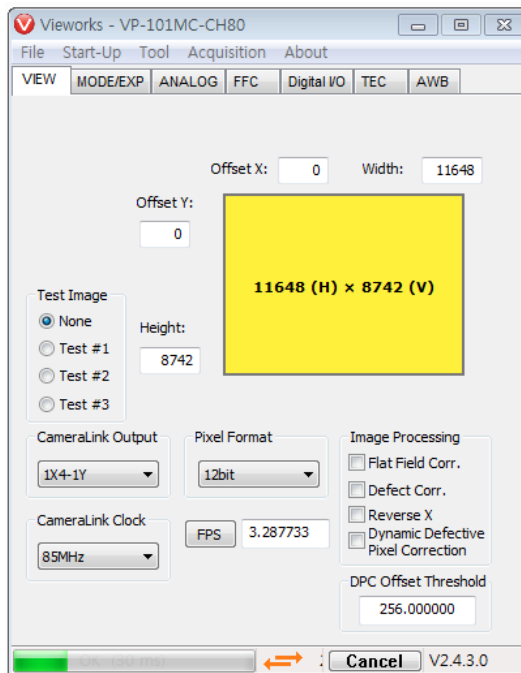

- Once the download is complete, the saving process will begin. If a power failure occurs during the saving process, the camera cannot be restored. Make sure that the power connection is secure.

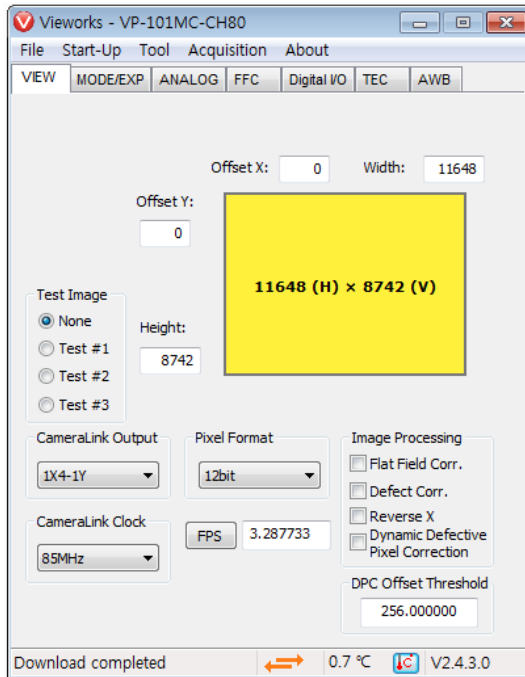

- Once all the processes are complete, turn the camera power off and turn it back on again. Select Tool > Terminal and enter the 'gmv' command to confirm the version. You can also select About > Camera Info to confirm the file version.





## Appendix C. Index

### 4

4-pin connector.....35

### 6

6-pin connector.....34

### A

acquisition control.....37

Acquisition Mode

    Continuous parameter.....37

Acquisition Mode parameter .....37

acquisition process.....53

Acquisition Start command.....37

Acquisition Stop command.....37

any edge.....42

### B

back panel.....29

block diagram .....21

### C

Camera Link connector..... 29

camera ON&OFF .....89

camera's pixel formats.....63

camera's temperature, parameters .....85

CC1 .....39

circuit .....36

command

    TargetTemperature .....84

    FanSpeed .....84

    FanOperationMode.....84

    PeltierOperationMode.....84

AWB Height.....66

AWB Offset X.....66

AWB Offset Y.....66

AWB Width .....66

BlackLevel.....68

Debounce Time .....82

Device Reset .....89

DeviceTemperature.....85

ExposureActive.....79

FlatFieldDataSelector .....72

FrameActive .....79

Gain .....68

GenerateFlatFieldData.....72

Hot Pixel Correction .....69

LineInverter .....79

LineSource .....79

LoadFlatFieldData .....72

ResetSequencer .....95

ReverseX.....88

ROI Height.....58

ROI Offset X .....58

ROI Offset Y .....58

ROI Width.....58

SaveFlatFieldData .....72

SensorSpecific.....86

SequencerConfigurationMode.....95

SequencerMode .....95  
 SequencerSetActive.....95  
 SequencerSetCount.....95  
 SequencerSetSelector.....95  
 SetFlatFieldCorrection .....72  
 Strobe .....79  
 Test Image .....86  
 Test Image 1 .....86  
 Test Image 2 .....86  
 Test Image 3 .....86  
 Timer0Active.....79  
 TimerDelay .....83  
 TimerDuration .....83  
 TimerReset .....83  
 TimerTriggerActivation.....83  
 TimerTriggerSource.....83  
 UserDefault.....93  
 UserOutput0.....79  
 UserOutputValue.....79  
 UserSetLoad.....93  
 UserSetSave.....93

Configurator .....28

Configurator download .....28

Continuous parameter .....37

**D**

diagram .....21

dimension.....26

downloading Configurator .....28

**E**

Exposure Mode

Timed .....39  
 TriggerWidth .....39

Exposure Mode parameter .....39

Exposure Offset.....50

**F**

falling edge .....42

Flat Field Correction data, generation.....72

frame acquisition process .....53

Free-run .....41

**G**

generating data of Flat Field correction .....72

**H**

Hirose .....34, 35

Hirose 4-pin connector .....35

Hirose 6-pin connector .....34

**K**

key features.....19

**L**

LED status .....85

level high .....42

level low .....42

Line0 .....39



**M**

main features .....	19
mechanical dimension .....	26
Mono 8/10/12 .....	63

**O**

overlapped exposure .....	53
---------------------------	----

**P**

pixel formats .....	63
preface .....	2, 4

**Q**

QE .....	22
quantum efficiency .....	22

**R**

reset physically .....	89
rising edge .....	42
ROI-origin position .....	59
ROI-size setting .....	59

**S**

schematic diagram .....	36
setting Exposure Time .....	50
Software .....	39
specification .....	20
spectral sensitivity .....	22
strobe output .....	36

**T**

tilt settings .....	28
Timed .....	39
trigger input .....	36
Trigger Signals .....	39
Trigger Source	
CC1 .....	39
Line0 .....	39
Software .....	39
UserOutput0 .....	39
Trigger Source parameter .....	39
TriggerWidth .....	39
TriggerWidth mode .....	49
<b>U</b>	
UserOutput0 .....	39

**V**

Vieworks Imaging Solution.....4	VP-101MC specification ..... 20
VIS.....4	VP-151MC specification ..... 20

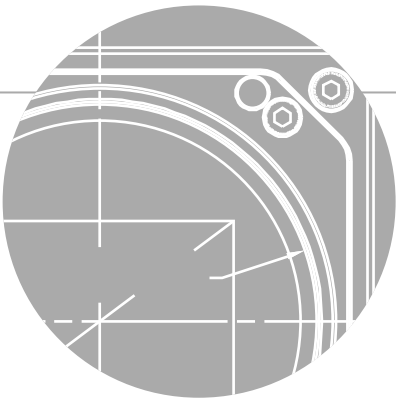
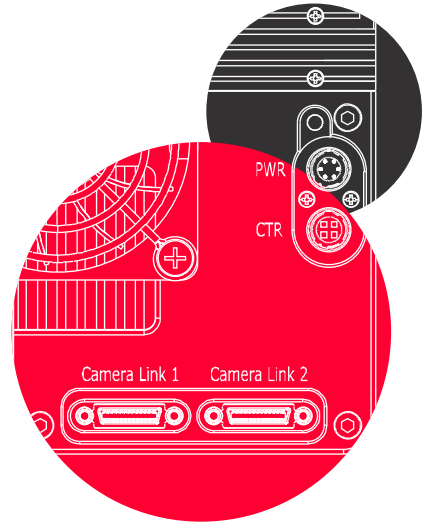
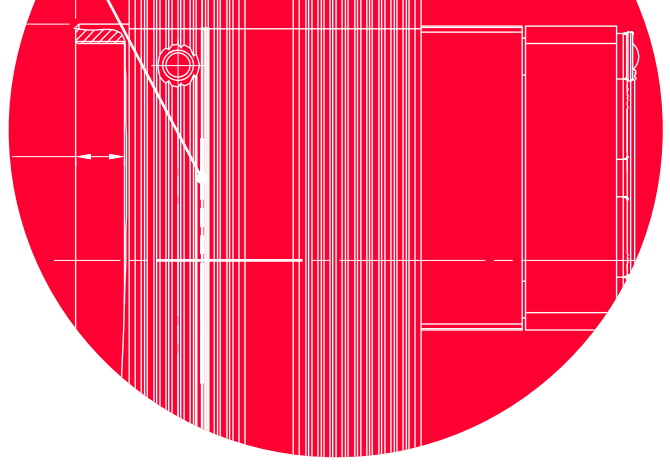

## Vieworks Co., Ltd.

41-3, Burim-ro, 170beon-gil,  
Dongan-gu, Anyang-si, Gyeonggi-do  
14055 Republic of Korea

Tel: +82-70-7011-6161

Fax: +82-31-386-8631

<http://vision.vieworks.com>

[vision@vieworks.com](mailto:vision@vieworks.com)