

# VP series

## User Manual

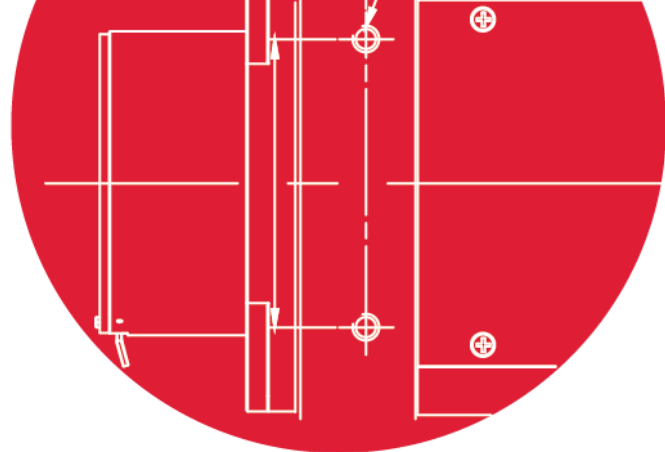

English

VP-50MX-M/C 30

**CoaPress**<sup>®</sup>

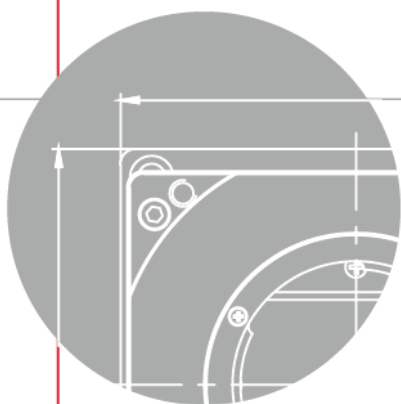

# VIEWWORKS

**Revision History**

Version	Date	Description
1.0	2018-04-27	Initial Release
1.1	2021-05-18	Corrected the orientation of the 4-pin connector in the user manual

# Contents

<b>1</b>	<b>Precautions</b>	<b>6</b>
<b>2</b>	<b>Warranty</b>	<b>7</b>
<b>3</b>	<b>Compliance &amp; Certifications</b>	<b>7</b>
3.1	FCC Compliance	7
3.2	CE: DoC	7
3.3	KC	7
<b>4</b>	<b>Package Components</b>	<b>8</b>
<b>5</b>	<b>Product Specifications</b>	<b>9</b>
5.1	Overview	9
5.2	Specifications	10
5.3	Camera Block Diagram	11
5.4	Sensor Information	12
5.5	Mechanical Specification	13
5.5.1	Camera Mounting and Heat Dissipation	14
<b>6</b>	<b>Connecting the Camera</b>	<b>15</b>
6.1	Mount Plate	16
6.2	Precaution to Connect the CXP Cables	17
6.3	Precaution to center the imaging sensor	17
6.4	Precaution about blurring compared to the center	17
6.5	Installing Vieworks Imaging Solution	17
<b>7</b>	<b>Camera Interface</b>	<b>18</b>
7.1	General Description	18
7.2	CoaXPress Connector	19
7.2.1	CoaXPress DIN Connector (75 $\Omega$ 1.0/2.3 DIN Receptacle)	19
7.3	Power Input Receptacle	20
7.4	Control I/O Receptacle	21
7.5	Trigger Input Circuit	22
7.6	Strobe Output Circuit	22
<b>8</b>	<b>Acquisition Control</b>	<b>23</b>
8.1	Overview	23
8.2	Acquisition Start/Stop Commands and Acquisition Mode	26

8.3	Exposure Start Trigger.....	27
8.3.1	Trigger Mode .....	27
8.3.2	Using a Software Trigger Signal.....	29
8.3.3	Using a CoaXPress Trigger Signal.....	30
8.3.4	Using an External Trigger Signal.....	31
8.4	Setting the Exposure Time.....	34
8.5	Overlapping Exposure with Sensor Readout .....	35
8.6	Electronic Shutter Operation.....	37
8.6.1	Global Shutter.....	37
8.7	Maximum Allowed Frame Rate .....	38
8.7.1	Increasing the Maximum Allowed Frame Rate .....	38
<b>9</b>	<b>Camera Features.....</b>	<b>39</b>
9.1	Image Region of Interest .....	39
9.2	Binning .....	42
9.3	CXP Link Configuration .....	44
9.4	Pixel Format .....	45
9.5	Data ROI (Color Camera).....	46
9.6	White Balance (Color Camera).....	47
9.6.1	Balance White Auto .....	47
9.7	Gain and Black Level.....	48
9.8	Defective Pixel Correction .....	49
9.8.1	Correction Method .....	49
9.9	Flat Field Correction .....	50
9.9.1	Flat Field Data Selector .....	53
9.10	Temperature Monitor .....	54
9.11	Status LED .....	54
9.12	Test Pattern .....	55
9.13	Reverse X .....	57
9.14	Digital IO Control .....	58
9.14.1	Debounce .....	60
9.15	Counter and Timer Control .....	61
9.16	Cooling Control.....	63
9.17	Device User ID .....	63
9.18	Device Reset.....	64
9.19	User Set Control.....	64
9.20	Field Upgrade.....	65
<b>10</b>	<b>Troubleshooting.....</b>	<b>66</b>

**Appendix A Defective Pixel Map Download .....67**

**Appendix B Field Upgrade.....69**

B.1 MCU ..... 69

B.2 FPGA ..... 71

B.3 XML..... 72

# 1 Precautions

## General



- Do not drop, disassemble, repair or alter the device. Doing so may damage the camera electronics and cause an electric shock.
- Do not let children touch the device without supervision.
- Stop using the device and contact the nearest dealer or manufacturer for technical assistance if liquid such as water, drinks or chemicals gets into the device.
- Do not touch the device with wet hands. Doing so may cause an electric shock.
- Make sure that the temperature of the camera does not exceed the temperature range specified in [5.2 Specifications](#). Otherwise the device may be damaged by extreme temperatures.

## Installation and Maintenance



- Do not install in dusty or dirty areas - or near an air conditioner or heater to reduce the risk of damage to the device.
- Avoid installing and operating in an extreme environment where vibration, heat, humidity, dust, strong magnetic fields, explosive/corrosive mists or gases are present.
- Do not apply excessive vibration and shock to the device. This may damage the device.
- Avoid direct exposure to a high intensity light source. This may damage the image sensor.
- Do not install the device under unstable lighting conditions. Severe lighting change will affect the quality of the image produced by the device.
- Do not use solvents or thinners to clean the surface of the device. This can damage the surface finish.

## Power Supply



- Applying incorrect power can damage the camera. If the voltage applied to the camera is greater or less than the camera's nominal voltage, the camera may be damaged or operate erratically. Please refer to [5.2 Specifications](#) for the camera's nominal voltage.
  - ※ Vieworks Co., Ltd. does NOT provide power supplies with the devices.
- Make sure the power is turned off before connecting the power cord to the camera. Otherwise damage to the camera may result.

## 2 Warranty

Do not open the housing of the camera. The warranty becomes void if the housing is opened.

For information about the warranty, please contact your local dealer or factory representative.

## 3 Compliance & Certifications

### 3.1 FCC Compliance

This equipment has been tested and found to comply with the limits for a Class A digital device, pursuant to part 15 of the FCC Rules. These limits are designed to provide reasonable protection against harmful interference when the equipment is operated in a commercial environment. This equipment generates, uses, and can radiate radio frequency energy and, if not installed and used in accordance with the instruction manual, may cause harmful interference to radio communications. Operation of this equipment in a residential area is likely to cause harmful interference in which case the user will be required to correct the interference at his own expenses.

### 3.2 CE: DoC

EMC Directive 2014/30/EU

EN 55032:2012 (Class A), EN 55024:2010

Class A

### 3.3 KC

#### KCC Statement

Type	Description
<b>Class A</b> (Broadcasting Communication Device for Office Use)	This device obtained EMC registration for office use (Class A), and may be used in places other than home. Sellers and/or users need to take note of this.

## 4 Package Components

### Package Components



VP-50MX with DIN 1.0/2.3 type connectors



**M5 Set Screws for Tilt Adjustment (Provided only with the F-mount camera)**



- You can adjust the tilt using the M5 set screws, however it is not recommended since it is adjusted as factory default settings.
- If the tilt settings need to be adjusted inevitably, please contact your local dealer or factory representative for technical support.



## 5 Product Specifications

### 5.1 Overview

The VP-50MX, the latest member of the industrial proven VP series, is a new 50 megapixel resolution CMOS camera with the CoaXPress interface. The VP-50MX camera uses the latest 50 megapixel CMOS imaging sensor (CMV50000) technology from AMS CMOSIS, and offers up to 30.9 frames per second at 7920 × 6004 resolution. This camera uses thermos-electric Peltier (TEC) cooling technology developed for, and used by, many demanding medical market customers. The TEC maintains the operating temperature of the CMOS imaging sensor at up to about 12 degrees below ambient temperature. This camera provides a stable operating condition or the ability to expose for a long period of time to increase camera sensitivity. Featured with the stable operating capability and high resolution, this camera is ideal for demanding applications such as FPD, PCB and semiconductor inspections.

#### Main Features

- High Speed 50 Megapixel CMOS Image Sensor
- Thermoelectric Peltier Cooling – about 12 degrees below ambient temperature
- Minimizing the number of hot pixels with TEC
- Electronic Exposure Time Control (Global Shutter)
- Output Pixel Format: 8 / 10 / 12 bit
- Strobe Output
- Output Channel: CXP6 × 1ch, CXP6 × 2ch, CXP6 × 4ch
- CoaXPress Interface up to 30.9 fps at 25 Gbps using 4 coax cables (4ch)
- Gain/Black Level Control
- Test Pattern
- Temperature Monitor
- Field Upgrade
- Image Correction (Pixel by pixel DSNU correction)
- Flat Field Correction
- Defective Pixel Correction
- VP-50MX Feature Bar



## 5.2 Specifications

The technical specifications of the VP-50MX camera are as follows:

Specifications		VP-50MX-30
Active Image (H × V)		7920 × 6004
Sensor Type		AMS CMOSIS CMV 50000
Pixel Size		4.6 μm × 4.6 μm
Optical Size (Diagonal)		35 mm (45.72 mm)
Output	Mono	Mono 8, Mono 10, Mono 12
Format	Color	BG Bayer 8, BG Bayer 10, BG Bayer 12
Camera Interface		CoaXPress
Electronic Shutter		Global Shutter
Max. Frame Rate at Full Resolution		30.9 fps at 6.25 Gbps with 4 CH
Dynamic Range		64 dB
Exposure Time (1 μs step)		1 μs ~ 60 s
Partial Scan (Max. Speed)		3968 fps at 4 Lines
Black Level (1 LSB step)		0 ~ 256 LSB at 12 bit (1 LSB step)
Video Gain		×1 ~ ×30
Exposure Mode		Free Run, Timed, Trigger Width
External Trigger		3.3 V ~ 24.0 V, 10 mA, Logical Level Input, Optically isolated, CoaXPress Control Port
Software Trigger		Asynchronous, Programmable via Camera API
API SDK		Vieworks Imaging Solution 7.X
Lens Mount		F-mount
Cooling Method		Thermoelectric Peltier Cooling
Cooling Performance		12°C below ambient temperature / Standard cooling with a fan
Power	External	10 ~ 24V DC, Typ. 24 W
	PoCXP	Not supported
Environmental		Operating: -5°C ~ 40°C, Storage: -40°C ~ 70°C
Mechanical		90 × 90 × 146 mm 1,400 g (with F-mount)

**Table 5.1 Specifications of VP-50MX**

## 5.3 Camera Block Diagram

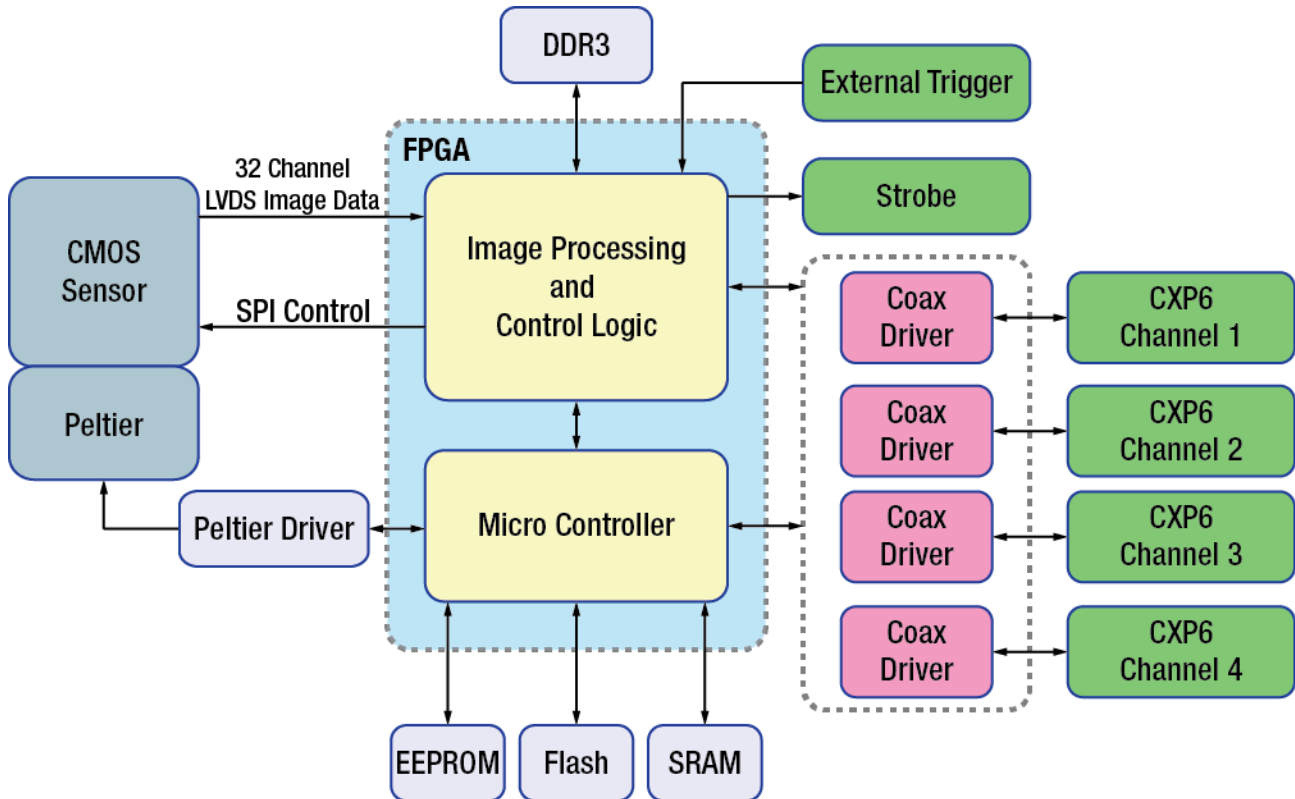

Figure 5.1 VP-50MX Block Diagram

All controls and data processing of the VP-50MX camera are carried out in one FPGA chip. The FPGA generally consists of a 32-bit RISC Micro-Controller and Processing & Control logic. The Micro-Controller receives commands from the user through the CoaXPRESS interface and then processes them. The Processing & Control logic processes the image data received from the CMOS imaging sensor and then transmits data through the CoaXPRESS interface. The Processing & Control logic also controls the trigger inputs and strobe outputs which are sensitive to time. Furthermore, Flash and DDR3 are installed outside FPGA. The DDR3 is used for the frame buffer to process images and the Flash stores the firmware to operate the Micro-Controller. And a Peltier Driver is applied to control a Thermoelectric Peltier Cooling unit.

## 5.4 Sensor Information

The following graphs show the quantum efficiency of the VP-50MX monochrome and color cameras.

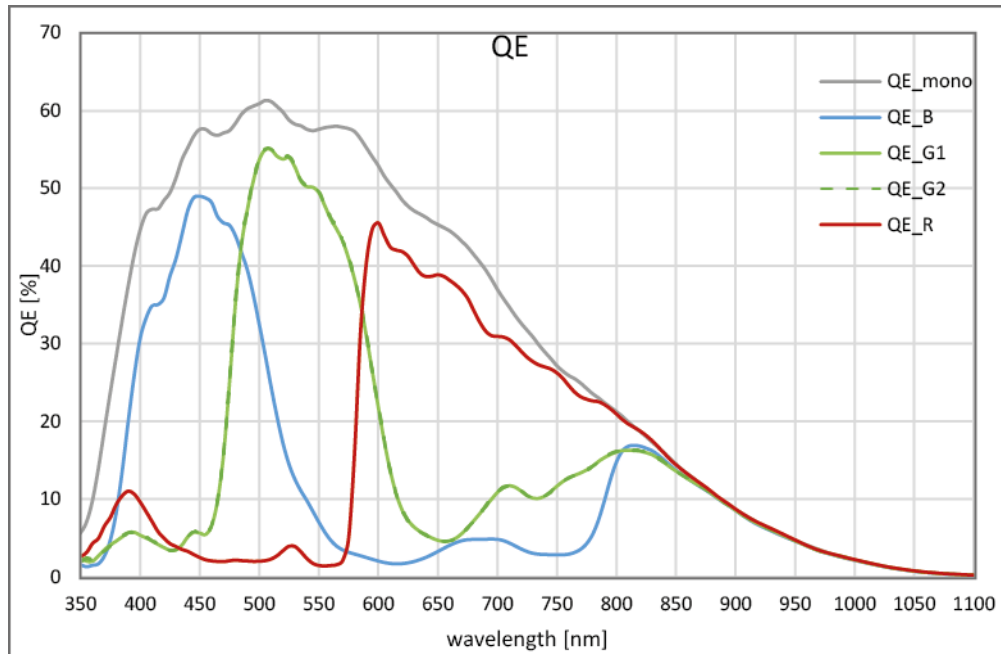

Figure 5.2 VP-50MX Quantum Efficiency

## 5.5 Mechanical Specification

The camera dimensions in millimeters are as shown in the following figure.

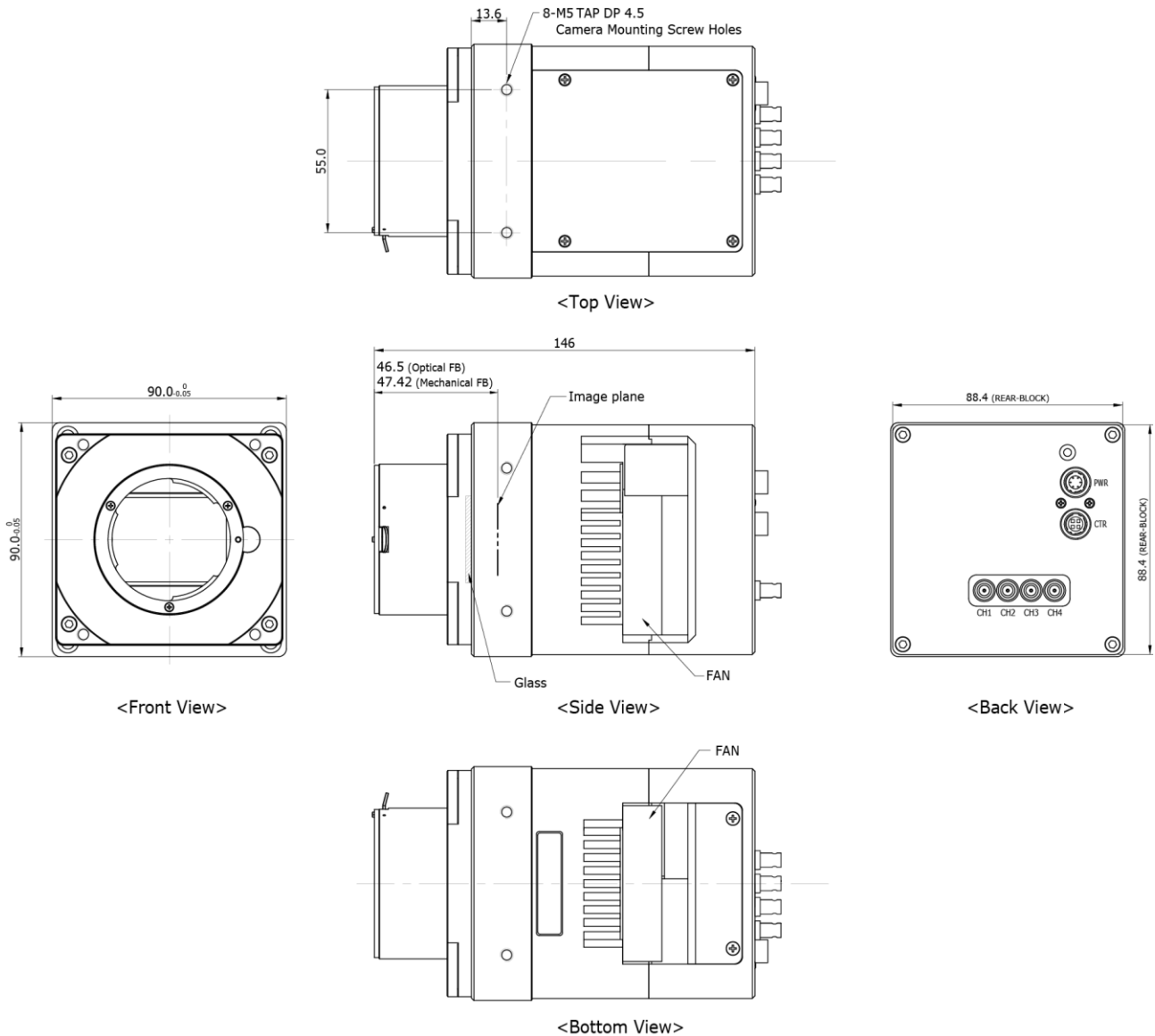

Figure 5.3 Mechanical Dimensions for VP-50MX F-mount with DIN 1.0/2.3-type Connectors

## 5.5.1 Camera Mounting and Heat Dissipation

### Camera Mounting Recommendations for Antivibration

When you mount a camera in a poor condition, the fan equipped on the camera may amplify vibrations which can lead to blurry images. Follow the instructions below to prevent and/or reduce vibrations caused by the fan.

- Fix the camera's front or side surface by using at least four screws.
- Prevent ingress of foreign objects between the camera and system surfaces.
- Keep the camera's center of gravity as near as possible to the system's center of gravity.
- If your lens' weight or size is greater than the camera's, make and use proper mounting brackets to support the lens.
- Prevent foreign matters from falling into the fan. This may cause damage to the fan blades.

### Camera Mounting Recommendations for Effective Heat Dissipation

- Do not obstruct the air inlets and outlets of the fan.
- If the fan is not available, leave enough space around the heat sink so that heat can be easily dissipated through the heat sink by natural convection.
- If the fan is not available, mount the camera on a metal structure made of high thermal conductive materials (e.g. Aluminum) to properly dissipate the heat generated by the camera.
- The contact surface of the camera must be at least 30% of the camera's Front-Block.

## 6 Connecting the Camera

The following instructions assume that you have installed a CoaXPress Frame Grabber (hereinafter 'CXP Frame Grabber') in your computer including related software. Procedures below also assume that you may attempt to configure a link between a camera and CXP Frame Grabber by using four coax cables. For more detailed information, refer to your CXP Frame Grabber User Manual.

To connect the camera to your computer, follow the steps below.

1. Make sure that the power supply is not connected to the camera and your computer is turned off.
2. Plug one end of a coax cable into the CH1 of the CXP connector on the camera and the other end of the coax cable into the CH1 of the CXP Frame Grabber in your computer. Then, plug one ends of the other three coax cables into the CH2, CH3 and CH4 of the CXP connector on the camera and the other ends of the coax cables into the CH2, CH3 and CH4 of the CXP Frame Grabber respectively.
3. Connect the plug of the power adapter to the 6-pin power input receptacle on the camera.
4. Plug the power adapter into a working electrical outlet.
5. Verify all the cable connections are secure.



The VP-50MX camera does not support Power over CoaXPress (PoCXP).

---

## 6.1 Mount Plate

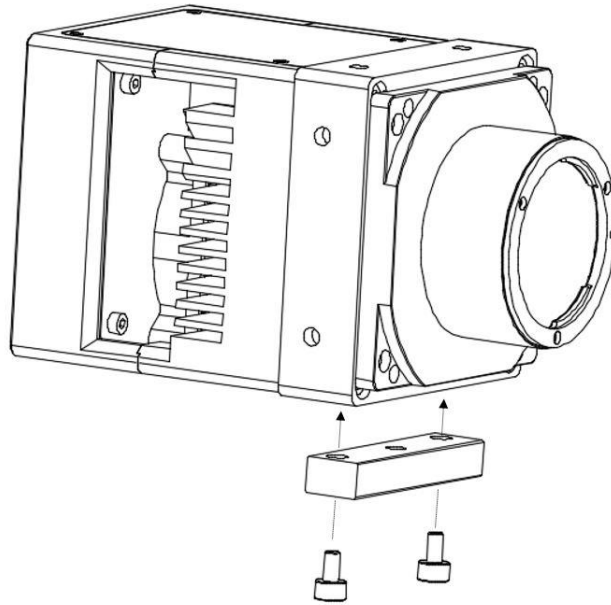

- The mount plate is provided as an optional item.
- The camera can be installed without using this mount plate.



## 6.2 Precaution to Connect the CXP Cables

External or system vibrations may result in loosening or disengagement of the CXP cables from the CXP DIN connectors. Vieworks recommends that you make a connector locking bracket for your application or use a dedicated locking bracket (available from Vieworks, sold separately) for securing the cables to the CXP DIN connectors.

## 6.3 Precaution to center the imaging sensor

- User does not need to center the imaging sensor as it is adjusted as factory default settings.
- When you need to adjust the center of the imaging sensor, please contact your local dealer or the factory representative for technical assistance.

## 6.4 Precaution about blurring compared to the center

- User does not need to adjust the tilt as it is adjusted as factory default settings.
- If the tilt settings need to be adjusted inevitably, please contact your local dealer or the factory representative for technical support.

## 6.5 Installing Vieworks Imaging Solution

You can download the Vieworks Imaging Solution at <http://www.vieworks.com>. You should perform the software installation first and then the hardware installation.

## 7 Camera Interface

### 7.1 General Description

As shown in the figure below, three types of connectors and one LED status indicator are located on the back of the VP-50MX camera and have the functions as follows:

- ① Status LED: displays power status and operation mode.
- ② 6-pin Power Input Receptacle: supplies power to the camera.
- ③ 4-pin Control Receptacle: inputs external trigger signal and outputs strobe.
- ④ CoaXPress Connectors: controls video data transmission and the camera.

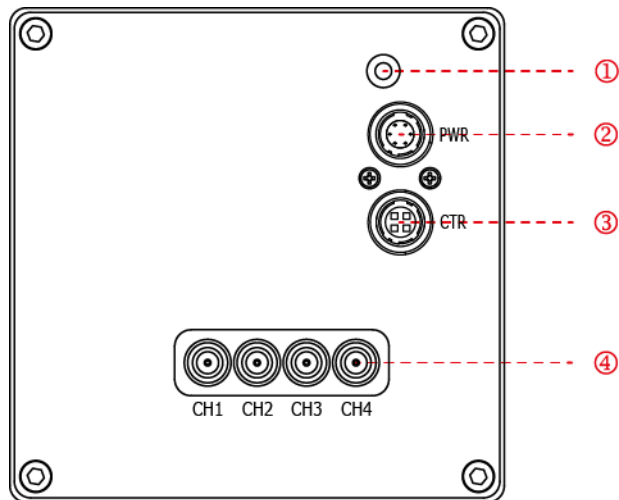

Figure 7.1 VP-50MX with DIN 1.0/2.3-type Connectors

## 7.2 CoaXPress Connector

CoaXPress protocol includes an automatic link detection mechanism (Plug and Play) to correctly detect the camera to the CXP Frame Grabber connection. The connection between the camera and CXP Frame Grabber uses a coax (also known as 'coaxial') cable and provides up to 6.25 Gbps bit rate per cable.

### 7.2.1 CoaXPress DIN Connector (75 $\Omega$ 1.0/2.3 DIN Receptacle)

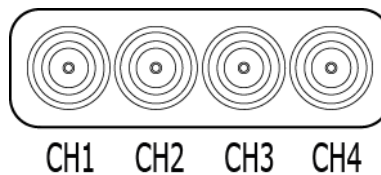

Figure 7.2 CoaXPress DIN 1.0/2.3-type Connectors

The CoaXPress connector on the VP-50MX camera complies with the CoaXPress standard and the following table shows the channel assignments.

Channel	Max. Bit Rate per Coax	Type
CH1	6.25 Gbps	Master Connection
CH2	6.25 Gbps	Extension Connection
CH3	6.25 Gbps	Extension Connection
CH4	6.25 Gbps	Extension Connection

Table 7.1 Channel Assignments for CoaXPress Connector



When you connect a camera to a CXP Frame Grabber using coax cables, make sure to connect the cables to their correct channels. If you connect the CH1 of the CXP connector on the camera to a channel other than CH1 of the CXP Frame Grabber, the camera may not transmit images properly or the serial communication between the computer and camera may fail.

## 7.3 Power Input Receptacle

The power input receptacle is a Hirose 6-pin connector (part # HR10A-7R-6PB). The pin assignments and configurations are as follows:

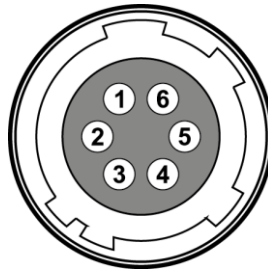

Figure 7.3 Pin Assignments for Power Input Receptacle

Pin Number	Signal	Type	Description
1, 2, 3	+12V DC	Input	DC Power Input
4, 5, 6	DC Ground	Input	DC Ground

Table 7.2 Pin Configurations for Power Input Receptacle



- A recommended mating connector for the Hirose 6-pin connector is the Hirose 6-pin plug (part # HR10A-7P-6S) or the equivalent connectors.
- It is recommended that you use the power adapter, which has at least 5 A current output at 10 ~ 24 V voltage output (You need to purchase a power adapter separately.).

### Precaution for Power Input



- Make sure the power is turned off before connecting the power cord to the camera. Otherwise, damage to the camera may result.
- If the voltage applied to the camera is greater than specified in the specifications, damage to the camera may result.

## 7.4 Control I/O Receptacle

The Control I/O Receptacle is a Hirose 4 pin connector (part # HR10A-7R-4S) and consists of an external trigger signal input and strobe output port. The pin assignments and configurations are as follows:

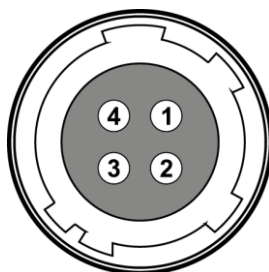

Figure 7.4 Pin Assignments for Control I/O Receptacle

Pin Number	Signal	Type	Description
1	Trigger Input +	Input	-
2	Trigger Input -	Input	-
3	DC Ground	-	DC Ground
4	Strobe Out	Output	3.3 V TTL Output Output Resistance: 47Ω

Table 7.3 Pin Configurations for Control I/O Receptacle



A recommended mating connector for the Hirose 4-pin connector is the Hirose 4-pin plug (part # HR10A-7P-4P) or the equivalent connectors.

## 7.5 Trigger Input Circuit

The following figure shows trigger signal input circuit of the 4 pin connector. Transmitted trigger signal is applied to the internal circuit through a photo coupler. The minimum trigger width that can be recognized by the camera is 1  $\mu$ s. If transmitted trigger signal is less than 1  $\mu$ s, the camera will ignore the trigger signal. An external trigger circuit example is shown below.

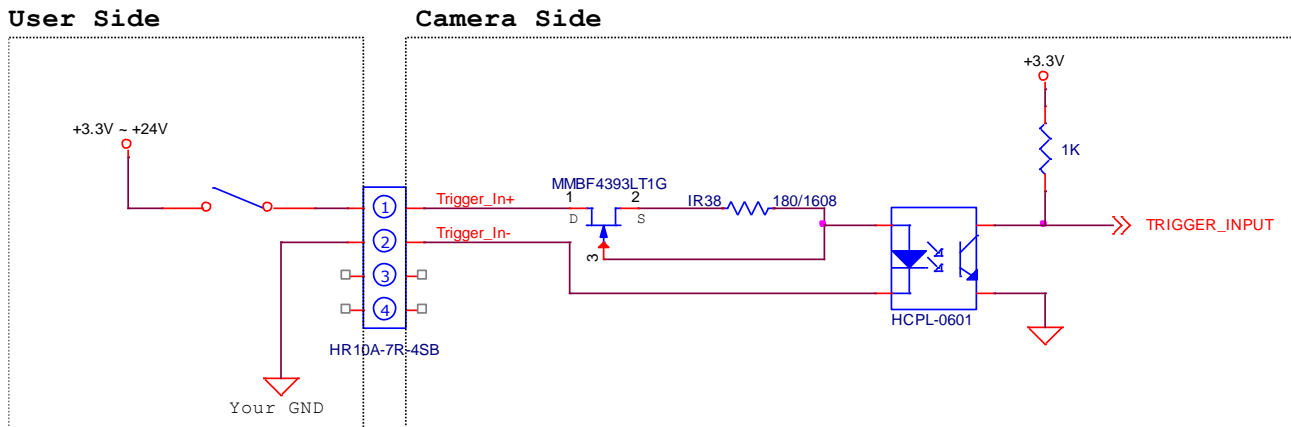

Figure 7.5 Trigger Input Schematic

## 7.6 Strobe Output Circuit

The strobe output signal comes out through a 3.3 V output level of TTL Driver IC. A pulse width of signal is synchronized with an exposure (shutter) signal of the camera (refer to [9.14 Digital IO Control](#)).

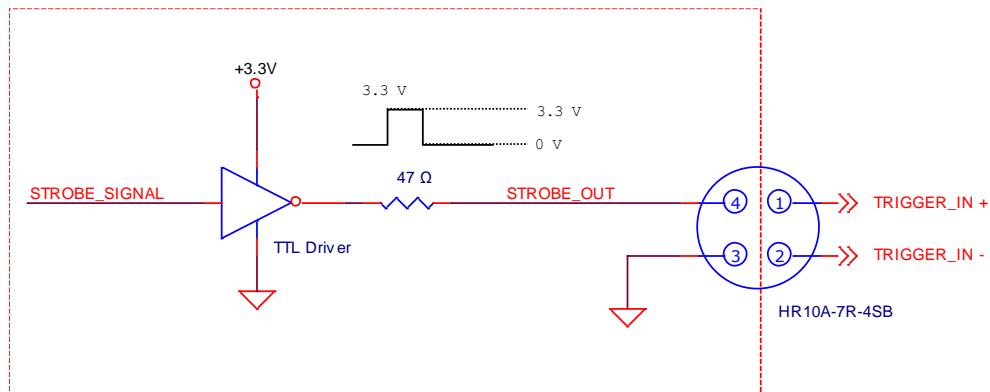

Figure 7.6 Strobe Output Schematic

## 8 Acquisition Control

This chapter provides detailed information about controlling image acquisition.

- Triggering image acquisition
- Setting the exposure time
- Controlling the camera's image acquisition rate
- Variation of the camera's maximum allowed image acquisition rate according to the camera settings

### 8.1 Overview

This section presents an overview of the elements involved with controlling the acquisition of images.

Three major elements are involved in controlling the acquisition of images:

- **Acquisition Start** and **Acquisition Stop** commands and the **Acquisition Mode** parameter
- Exposure start trigger
- Exposure time control



When reading the explanations in the overview and in this entire chapter, keep in mind that the term **frame** is typically used to mean a single acquired image.

#### Acquisition Start and Stop Commands and the Acquisition Mode

The **Acquisition Start** command prepares the camera to acquire frames. The camera cannot acquire frames unless an **Acquisition Start** command has first been executed.

A parameter called the **Acquisition Mode** has a direct bearing on how the **Acquisition Start** command operates. The VP-50MX camera only supports **Continuous** for the **Acquisition Mode** parameter.

If the **Acquisition Mode** parameter is set to **Continuous**, an **Acquisition Start** command does not expire after a single frame is acquired. Once an **Acquisition Start** command has been executed, you can acquire as many frames as you like. The **Acquisition Start** command will remain in effect until you execute an **Acquisition Stop** command. Once an **Acquisition Stop** command has been executed, the camera will not be able to acquire frames until a new **Acquisition Start** command is executed.

## Exposure Start Trigger

Applying an exposure start trigger signal to the camera will exit the camera from the *waiting for exposure start trigger* acquisition status and will begin the process of exposing and reading out a frame (see Figure 8.1).

As soon as the camera is ready to accept another exposure start trigger signal, it will return to the *waiting for exposure start trigger* acquisition status. A new exposure start trigger signal can then be applied to the camera to begin another frame exposure.

The exposure start trigger has two modes: off and on.

If the **Trigger Mode** parameter is set to **Off**, the camera will generate all required exposure start trigger signals internally, and you do not need to apply exposure start trigger signals to the camera. The rate at which the camera will generate the signals and acquire frames will be determined by the way that you set several frame rate related parameters.

If the **Trigger Mode** parameter is set to **On**, you must trigger exposure start by applying exposure start trigger signals to the camera. Each time a trigger signal is applied, the camera will begin a frame exposure. When exposure start is being triggered in this manner, it is important that you do not attempt to trigger frames at a rate that is greater than the maximum allowed (There is a detailed explanation about the maximum allowed frame rate at the end of this chapter.). Exposure start trigger signals applied to the camera when it is not in a *waiting for exposure start trigger* acquisition status will be ignored.

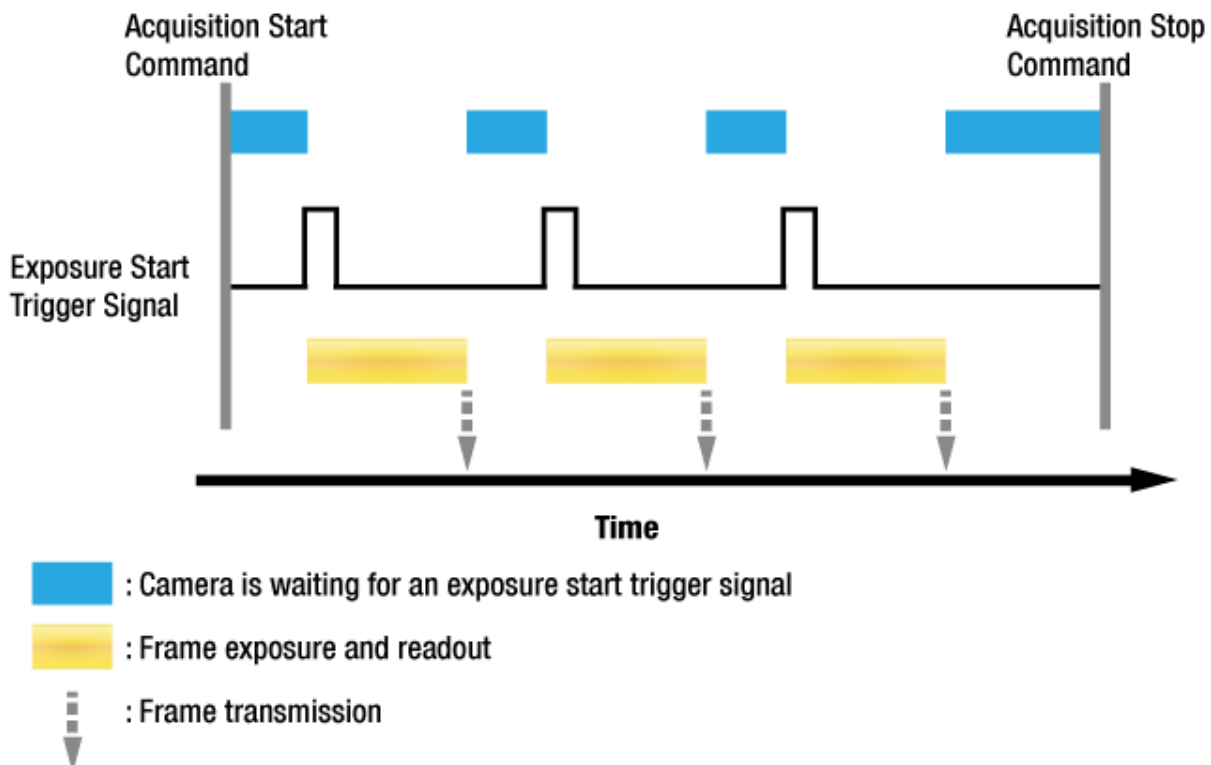

Figure 8.1 Exposure Start Triggering



## Applying Trigger Signals

The paragraphs above mention "applying a trigger signal". There are three ways to apply an exposure start trigger signal to the camera: via **Software**, via **CXPin** or via **LineIn0** (commonly referred to as hardware).

To apply trigger signals via **Software**, you must set the **Trigger Source** parameter to **Software**. At that point, each time a **Trigger Software** command is executed, the exposure start trigger signal will be applied to the camera.

To apply trigger signals via CH1 of the CXP Frame Grabber, you must set the **Trigger Source** parameter to **CXPin**. At that point, each time a proper CoaXPress trigger signal is applied to the camera by using the APIs provided by a CXP Frame Grabber manufacturer, the exposure start trigger signal will be applied to the camera. For more information, refer to your CXP Frame Grabber User Manual.

To apply trigger signals via hardware (external), you must set the **Trigger Source** parameter to **LineIn0**. At that point, each time a proper electrical signal is applied to the camera, an occurrence of the exposure start trigger signal will be recognized by the camera.

## Exposure Time Control

When an exposure start trigger signal is applied to the camera, the camera will begin to acquire a frame.

A critical aspect of frame acquisition is how long the pixels in the camera's sensor will be exposed to light during the frame acquisition.

If the **Trigger Source** parameter is set to **Software**, a parameter called the **Exposure Time** will determine the exposure time for each frame. At this point, you must set the **Exposure Mode** parameter to **Timed**.

If the **Trigger Source** parameter is set to **CXPin** or **LineIn0**, there are two modes of operation: **Timed** and **Trigger Width**.

With the **Timed** mode, the **Exposure Time** parameter will determine the exposure time for each frame.

With the **Trigger Width** mode, the way that you manipulate the rise and fall of the CoaXPress or external signal will determine the exposure time. The **Trigger Width** mode is especially useful if you want to change the exposure time from frame to frame.

## 8.2 Acquisition Start/Stop Commands and Acquisition Mode

Executing an **Acquisition Start** command prepares the camera to acquire frames. You must execute an **Acquisition Start** command before you can begin acquiring frames. Executing an **Acquisition Stop** command terminates the camera's ability to acquire frames. When the camera receives an **Acquisition Stop** command:

- If the camera is not in the process of acquiring a frame, its ability to acquire frames will be terminated immediately.
- If the camera is in the process of acquiring a frame, the frame acquisition process will be allowed to finish and the camera's ability to acquire new frames will be terminated.

The VP-50MX camera only provides the '**Continuous**' mode of operation for the **Acquisition Mode**.

After an **Acquisition Start** command has been executed, exposure start can be triggered as desired. Each time an exposure start trigger is applied while the camera is in a *waiting for exposure start trigger* acquisition status, the camera will acquire and transmit a frame. The camera will retain the ability to acquire frames until an **Acquisition Stop** command is executed. Once the **Acquisition Stop** command is received, the camera will no longer be able to acquire frames.

## 8.3 Exposure Start Trigger

The **Trigger Selector** parameter is used to select a type of trigger and only the **Exposure Start** trigger is available on the VP-50MX camera. The Exposure Start trigger is used to begin frame acquisition.

Exposure start trigger signals can be generated within the camera or may be applied externally by setting the **Trigger Source** parameter to **Software**, **CXPin** or **LineIn0**. If an exposure start trigger signal is applied to the camera, the camera will begin to expose a frame.

### 8.3.1 Trigger Mode

The main parameter associated with the exposure start trigger is the **Trigger Mode** parameter. The **Trigger Mode** parameter for the exposure start trigger has two available settings: **Off** and **On**.

#### 8.3.1.1 Trigger Mode = Off

When the **Trigger Mode** parameter is set to **Off**, the camera will generate all required exposure start trigger signals internally, and you do not need to apply exposure start trigger signals to the camera.

If the **Trigger Mode** parameter is set to **Off**, the camera will automatically begin generating exposure start trigger signals when it receives an **Acquisition Start** command. The camera will continue to generate exposure start trigger signals until it receives an **Acquisition Stop** command.



#### Free Run

When you set the **Trigger Mode** parameter to **Off**, the camera will generate all required trigger signals internally. When the camera is set this way, it will constantly acquire images without any need for triggering by the user. This use case commonly referred as “free run”.

The rate at which the exposure start trigger signals are generated may be determined by the camera's **Acquisition Frame Rate** parameter.

- If the parameter is set to a value less than the maximum allowed frame rate with the current camera settings, the camera will generate exposure start trigger signals at the rate specified by the parameter setting.
- If the parameter is set to a value greater than the maximum allowed frame rate with the current camera settings, the camera will generate exposure start trigger signals at the maximum allowed frame rate.

#### Exposure Time Control with Trigger Mode = Off

When the **Trigger Mode** parameter is set to **Off**, the exposure time for each frame acquisition is determined by the value of the camera's **Exposure Time** parameter. For more information about the Exposure Time parameter, see [8.4 Setting the Exposure Time](#).

### 8.3.1.2 Trigger Mode = On

When the **Trigger Mode** parameter is set to **On**, you must apply an exposure start trigger signal to the camera each time you want to begin a frame acquisition. The **Trigger Source** parameter specifies the source signal that will act as the exposure start trigger signal.

The available settings for the **Trigger Source** parameter are:

- **Software:** You can apply an exposure start trigger signal to the camera by executing a **Trigger Software** command for the exposure start trigger on your computer.
- **CXPin:** You can apply an exposure start trigger signal via CH1 of the CXP Frame Grabber. For more information, refer to your CXP Frame Grabber User Manual.
- **LineIn0:** You can apply an exposure start trigger signal to the camera by injecting an externally generated electrical signal (commonly referred to as a hardware or external trigger signal) into the Control I/O receptacle on the camera. Refer to [7.5 Trigger Input Circuit](#) for more information.

You must also set the **Trigger Activation** parameter after setting the **Trigger Source** parameter.

The available settings for the **Trigger Activation** parameter are:

- **Rising Edge:** Specifies that a rising edge of the electrical signal will act as the exposure start trigger.
- **Falling Edge:** Specifies that a falling edge of the electrical signal will act as the exposure start trigger.

### Exposure Time Control with Trigger Mode = On

When the **Trigger Mode** parameter is set to **On** and the **Trigger Source** parameter is set to **Software**, the exposure time for each frame acquisition is determined by the value of the camera's **Exposure Time** parameter.

When the **Trigger Mode** parameter is set to **On** and the **Trigger Source** parameter is set to **CXPin** or **LineIn0**, the exposure time for each frame acquisition can be controlled with the **Exposure Time** parameter or it can be controlled by manipulating the external trigger signal.

### 8.3.2 Using a Software Trigger Signal

If the **Trigger Mode** parameter is set to **On** and the **Trigger Source** parameter is set to **Software**, you must apply a software trigger signal (exposure start) to the camera to begin each frame acquisition. Assuming that the camera is in a *waiting for exposure start trigger* acquisition status, frame exposure will start when the software trigger signal is received by the camera. Figure 8.2 illustrates frame acquisition with a software trigger signal.

When the camera receives a software trigger signal and begins exposure, it will exit the *waiting for exposure start trigger* acquisition status because at that point, it cannot react to a new exposure start trigger signal.

As soon as the camera is capable of reacting to a new exposure start trigger signal, it will automatically return to the *waiting for exposure start trigger* acquisition status.

When you are using a software trigger signal to start each frame acquisition, the camera's **Exposure Mode** parameter must be set to **Timed**. The exposure time for each acquired frame will be determined by the value of the camera's **Exposure Time** parameter.



When you use a software trigger signal to acquire frames, be aware that there is a Trigger Latency due to the characteristics of the CoaXPress. Use an external trigger signal to precisely synchronize the trigger signal with the exposure timing.

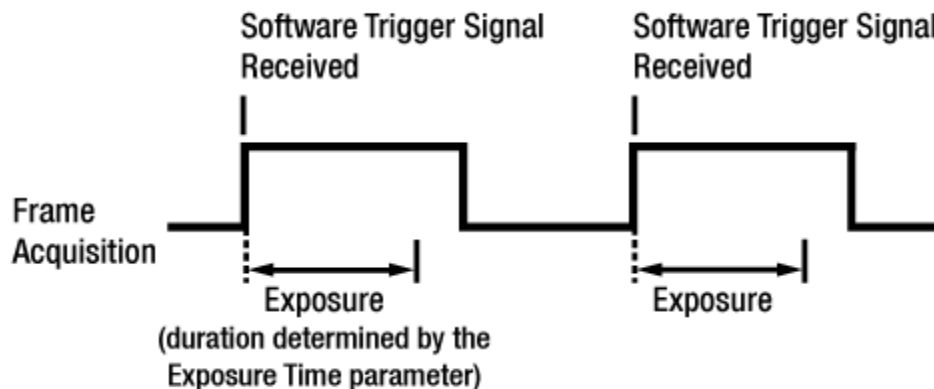

**Figure 8.2 Frame Acquisition with Software Trigger Signal**

When you are using a software trigger signal to start each frame acquisition, the frame rate will be determined by how often you apply a software trigger signal to the camera, and you should not attempt to trigger frame acquisition at a rate that exceeds the maximum allowed for the current camera settings (There is a detailed explanation about the maximum allowed frame rate at the end of this chapter.). Software trigger signals that are applied to the camera when it is not ready to receive them will be ignored.

### 8.3.3 Using a CoaXPress Trigger Signal

If the **Trigger Mode** parameter is set to **On** and the **Trigger Source** parameter is set to **CXPin**, you must apply a CoaXPress trigger signal to the camera to begin each frame acquisition. A CoaXPress trigger signal will act as the exposure start trigger signal for the camera. For more information, refer to your CXP Frame Grabber User Manual.

A rising edge or a falling edge of the CoaXPress signal can be used to trigger frame acquisition. The **Trigger Activation** parameter is used to select rising edge or falling edge triggering.

Assuming that the camera is in a *waiting for exposure start trigger* acquisition status, frame acquisition will start whenever the appropriate edge transition is received by the camera.

When the camera receives a CoaXPress trigger signal and begins exposure, it will exit the waiting for exposure start trigger acquisition status because at that point, it cannot react to a new exposure start trigger signal.

As soon as the camera is capable of reacting to a new exposure start trigger signal, it will automatically return to the *waiting for exposure start trigger* acquisition status.

When the camera is operating under control of a CoaXPress signal, the period of the CoaXPress trigger signal will determine the rate at which the camera is acquiring frames:

$$\frac{1}{\text{CoaXPress signal period in seconds}} = \text{Frame Rate}$$

For example, if you are operating a camera with a CoaXPress trigger signal period of 50 ms (0.05 s):

So in this case, the frame rate is 20 fps.

### 8.3.4 Using an External Trigger Signal

If the **Trigger Mode** parameter is set to **On** and the **Trigger Source** parameter is set to **LineIn0**, an externally generated electrical signal injected into the Control I/O Receptacle pin 1 will act as the exposure start trigger signal for the camera. This type of trigger signal is generally referred to as a hardware trigger signal.

A rising edge or a falling edge of the external signal can be used to trigger frame acquisition. The **Trigger Activation** parameter is used to select rising edge or falling edge triggering.

Assuming that the camera is in a *waiting for exposure start trigger* acquisition status, frame acquisition will start whenever the appropriate edge transition is received by the camera.

When the camera receives an external trigger signal and begins exposure, it will exit the *waiting for exposure start trigger* acquisition status because at that point, it cannot react to a new exposure start trigger signal.

As soon as the camera is capable of reacting to a new exposure start trigger signal, it will automatically return to the *waiting for exposure start trigger* acquisition status.

When the camera is operating under control of an external signal, the period of the external trigger signal will determine the rate at which the camera is acquiring frames:

$$\frac{1}{\text{External signal period in seconds}} = \text{Frame Rate}$$

For example, if you are operating a camera with an External trigger signal period of 50 ms (0.05 s):

So in this case, the frame rate is 20 fps.

### 8.3.4.1 Exposure Mode

If you are triggering the start of frame acquisition with an externally (CoaXPress or External) generated trigger signal, two exposure modes are available: **Timed** and **Trigger Width**.

#### Timed Exposure Mode

When the **Timed** mode is selected, the exposure time for each frame acquisition is determined by the value of the camera's **Exposure Time** parameter. If the camera is set for rising edge triggering, the exposure time starts when the external trigger signal rises. If the camera is set for falling edge triggering, the exposure time starts when the external trigger signal falls. Figure 8.3 illustrates **Timed** exposure with the camera set for rising edge triggering.

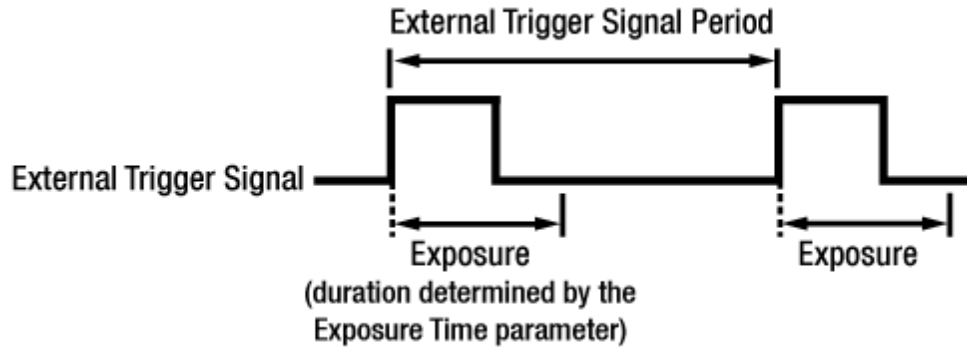

Figure 8.3 Timed Exposure Mode

Note that if you attempt to trigger a new exposure start while the previous exposure is still in progress, the trigger signal will be ignored.

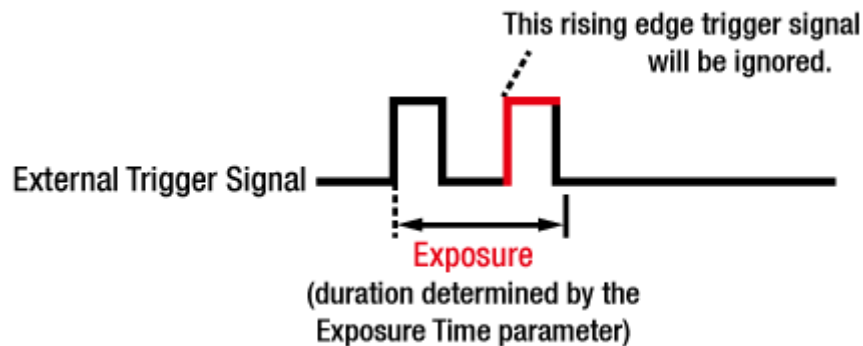

Figure 8.4 Trigger Overlapped with Timed Exposure Mode



## Trigger Width Exposure Mode

When the **Trigger Width** exposure mode is selected, the length of the exposure for each frame acquisition will be directly controlled by the external trigger signal (CoaXPress or External). If the camera is set for rising edge triggering, the exposure time begins when the external trigger signal rises and continues until the external trigger signal falls. If the camera is set for falling edge triggering, the exposure time begins when the external trigger signal falls and continues until the external trigger signal rises. Figure 8.5 illustrates **Trigger Width** exposure with the camera set for rising edge triggering.

**Trigger Width** exposure is especially useful if you intend to vary the length of the exposure time for each frame.

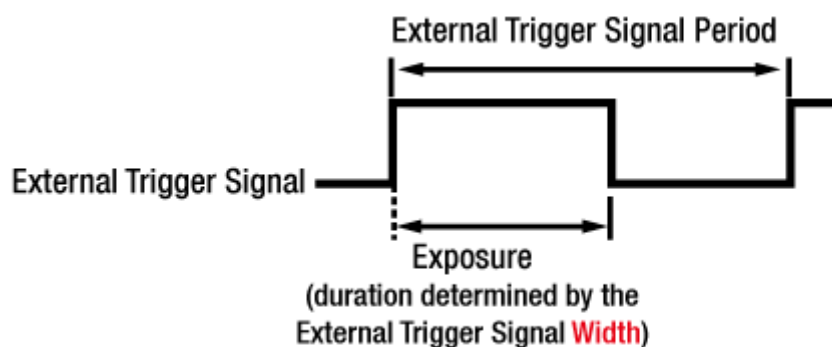

Figure 8.5 Trigger Width Exposure Mode

## 8.4 Setting the Exposure Time

This section describes how the exposure time can be adjusted manually by setting the value of the **Exposure Time** parameter. If you are operating the camera in any one of the following ways, you must specify an exposure time by setting the camera's **Exposure Time** parameter.

- the **Trigger Mode** is set to **Off**
- the **Trigger Mode** is set to **On** and the **Trigger Source** is set to **Software** (In this case, you must set the **Exposure Mode** parameter to **Timed**.)
- the **Trigger Mode** is set to **On**, the **Trigger Source** is set to **CXPIn** or **LineIn0**, and the **Exposure Mode** is set to **Timed**.

The **Exposure Time** parameter must not be set below a minimum specified value. The **Exposure Time** parameter sets the exposure time in microseconds ( $\mu s$ ). The minimum and maximum exposure time settings for the VP-50MX camera are shown in the following table.

Camera Model	Number of Channels	Minimum Exposure Time	Maximum Exposure Time <sup>†</sup>
VP-50MX	1 Channel	1 $\mu s$	60,000,000 $\mu s$
	2 Channels	1 $\mu s$	60,000,000 $\mu s$
	4 Channels	1 $\mu s$	60,000,000 $\mu s$

<sup>†</sup>: When the **Exposure Mode** is set to **Trigger Width**, the exposure time is controlled by the external trigger signal and has no maximum limit.

**Table 8.1 Minimum and Maximum Exposure Time Setting**

## 8.5 Overlapping Exposure with Sensor Readout

The frame acquisition process on the camera includes two distinct parts. The first part is the exposure of the pixels in the imaging sensor. Once exposure is complete, the second part of the process – readout of the pixel values from the sensor – takes place. In regard to this frame acquisition process, the VP-50MX camera basically operates with ‘overlapped’ exposure so that the exposure for a new frame can be overlapped with the sensor readout for the previous frame.

When the **Trigger Mode** parameter is set to **On**, the exposure of a new frame begins while the camera is still reading out the sensor data for the previously acquired frame. This situation is illustrated in Figure 8.6 with the **Trigger Source** parameter set to **LineIn0** and the **Exposure Mode** parameter set to **Trigger Width**.

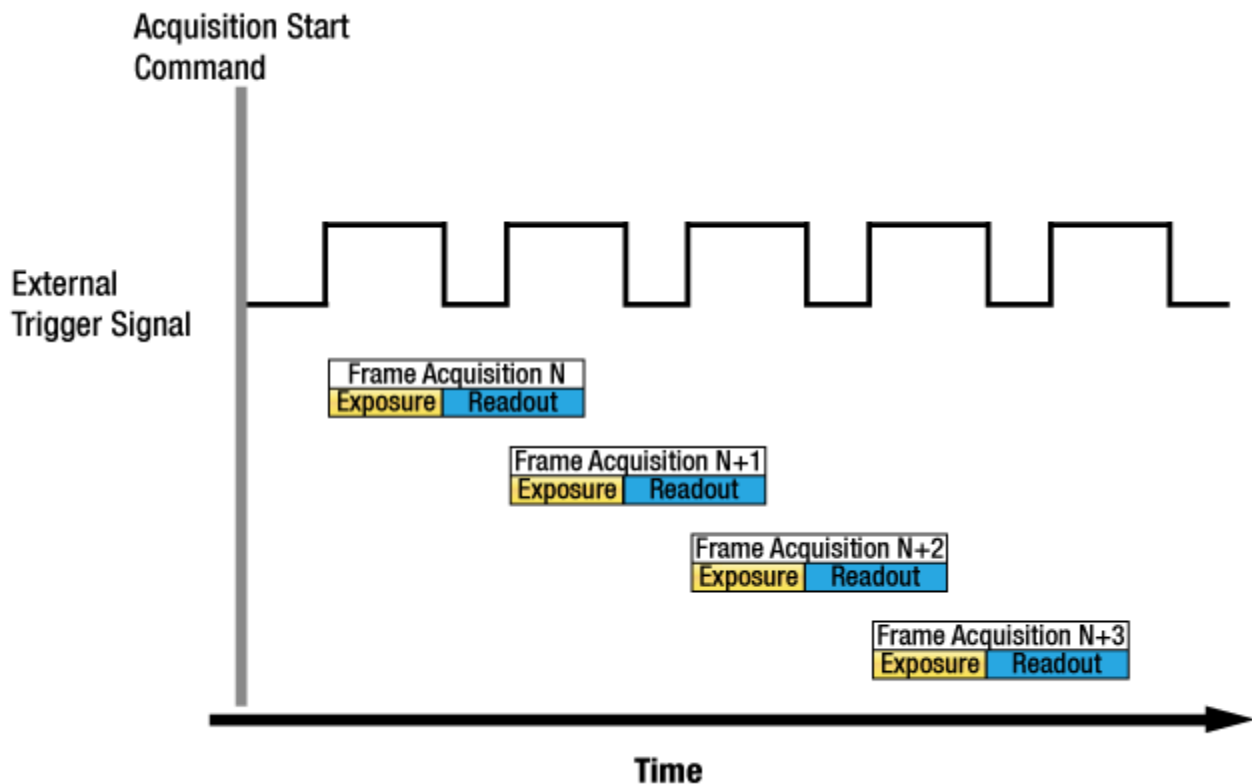

Figure 8.6 Overlapped Exposure and Readout

Determining whether your camera is operating with overlapped exposure and readout is not a matter of issuing a command or changing a setting. Rather a way that you operate the camera will determine whether the exposures and readouts are overlapped or not. If we define the “Frame Period” as the time from the start of exposure for one frame acquisition to the start of exposure for the next frame acquisition, then:

- Overlapped:  $\text{Frame Period} \leq \text{Exposure Time} + \text{Readout Time}$

## Guidelines for Overlapped Exposure

Since the VP-50MX camera operates with overlapped exposure, there are two important guidelines to keep in mind:

- You must not begin the exposure time for a new image acquisition while the exposure time of the previous acquisition is in progress.
- You must not end the exposure time of the current image acquisition until readout of the previously acquired image is complete.

When you are operating a camera with overlapped exposure and using an external trigger signal to trigger image acquisition, you could use the camera's Exposure Time parameter settings and timing formula to calculate when it is safe to begin each new acquisition.

## 8.6 Electronic Shutter Operation

The VP-50MX camera is equipped with an imaging sensor that has an electronic shutter. There are two types of electronic shutters, i.e. global and rolling. The VP-50MX camera uses the sensor with the global shutter.

### 8.6.1 Global Shutter

When an exposure start trigger signal is applied to the camera equipped with a global shutter, exposure begins for all lines in the sensor as shown in Figure 8.7. Exposure continues for all lines in the sensor until the programmed exposure time ends or when the exposure start trigger signal ends the exposure time if the camera is using the trigger width exposure mode. At the end of the exposure time, exposure ends for all lines in the sensor. Immediately after the end of exposure, pixel data readout begins and proceeds line by line until all pixel data is read out of the sensor. A main characteristic of a global shutter is that for each frame acquisition, all of the pixels in the sensor start exposing at the same time and all end exposing at the same time. This means that image brightness tends to be more uniform over the entire area of each acquired image, and it helps to minimize problems with acquiring images of object in motion.

The camera can provide an **Exposure Active** output signal that will go high when the exposure time for a frame acquisition begins and will go down when the exposure time ends.

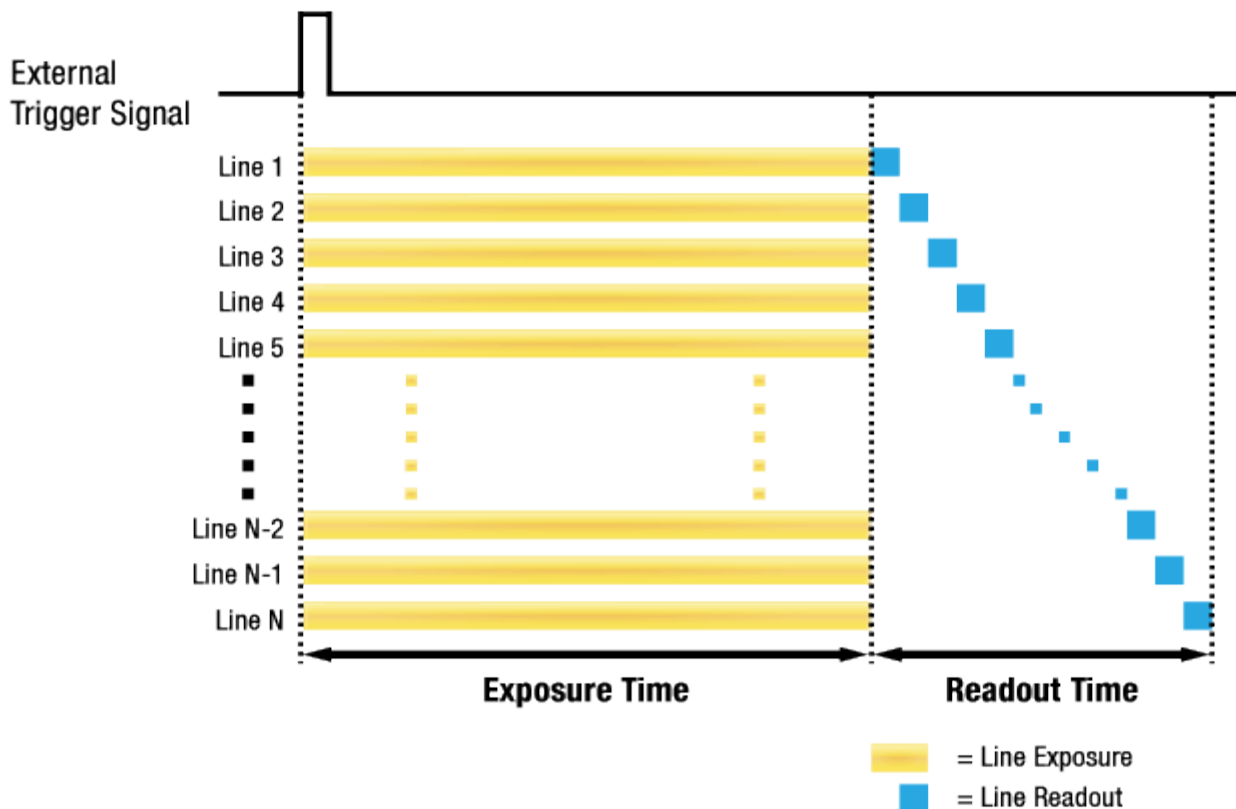

Figure 8.7 Global Shutter

## 8.7 Maximum Allowed Frame Rate

In general, the maximum allowed acquisition frame rate on the camera may be limited by several factors:

- The amount of time that it takes to transmit an acquired frame from the camera to your computer.  
The amount of time needed to transmit a frame depends on the bandwidth assigned to the camera.
- The amount of time it takes to read an acquired frame out of the imaging sensor and into the camera's frame buffer. This time varies depending on the setting for the **Height** parameter. Frames with a smaller height take less time to read out of the sensor. The frame height is determined by the camera's **Height** settings (**Image Format Control**).
- The exposure time for acquired frames. If you use very long exposure times, you can acquire fewer frames per second.

### 8.7.1 Increasing the Maximum Allowed Frame Rate

You may find that you would like to acquire frames at a rate higher than the maximum allowed with the camera's current settings. In this case, you must adjust one or more of the factors that can influence the maximum allowed frame rate and then check to see if the maximum allowed frame rate has increased:

- The time that it takes to transmit a frame out of the camera is the main limiting factor on the frame rate. You can decrease the frame transmission time (and thus increase the maximum allowed frame rate) by using the ROI feature.
  - Use a smaller ROI. Decreasing the ROI means that the camera has less data to transmit and therefore the transmission time will decrease.
- If you are using normal exposure times and you are using the camera at its maximum resolution, your exposure time will not normally restrict the frame rate. However, if you are using long exposure times or small region of interest, it is possible that your exposure time is limiting the maximum allowed frame rate. If you are using a long exposure time or a small ROI, try using a shorter exposure time and see if the maximum allowed frame rate increases (You may need to compensate for a lower exposure time by using a brighter light source or increasing the opening of your lens aperture.).



A very long exposure time severely limits the camera's maximum allowed frame rate.

As an example, assume that your camera is set to use a 1 second exposure time. In this case, because each frame acquisition will take at least 1 second to be completed, the camera will only be able to acquire a maximum of one frame per second.

## 9 Camera Features

### 9.1 Image Region of Interest

The Image Region of Interest (ROI) feature allows you to specify a portion of the sensor array. You can acquire only the frame data from the specified portion of the sensor array while preserving the same quality as you acquire a frame from the entire sensor array.

With the ROI feature, you can achieve increased frame rates by decreasing the **Height** of the ROI; however, decreasing the **Width** of the ROI does not affect the frame rate.

The ROI is referenced to the top left corner [origin (0, 0)] of the sensor array as follows.

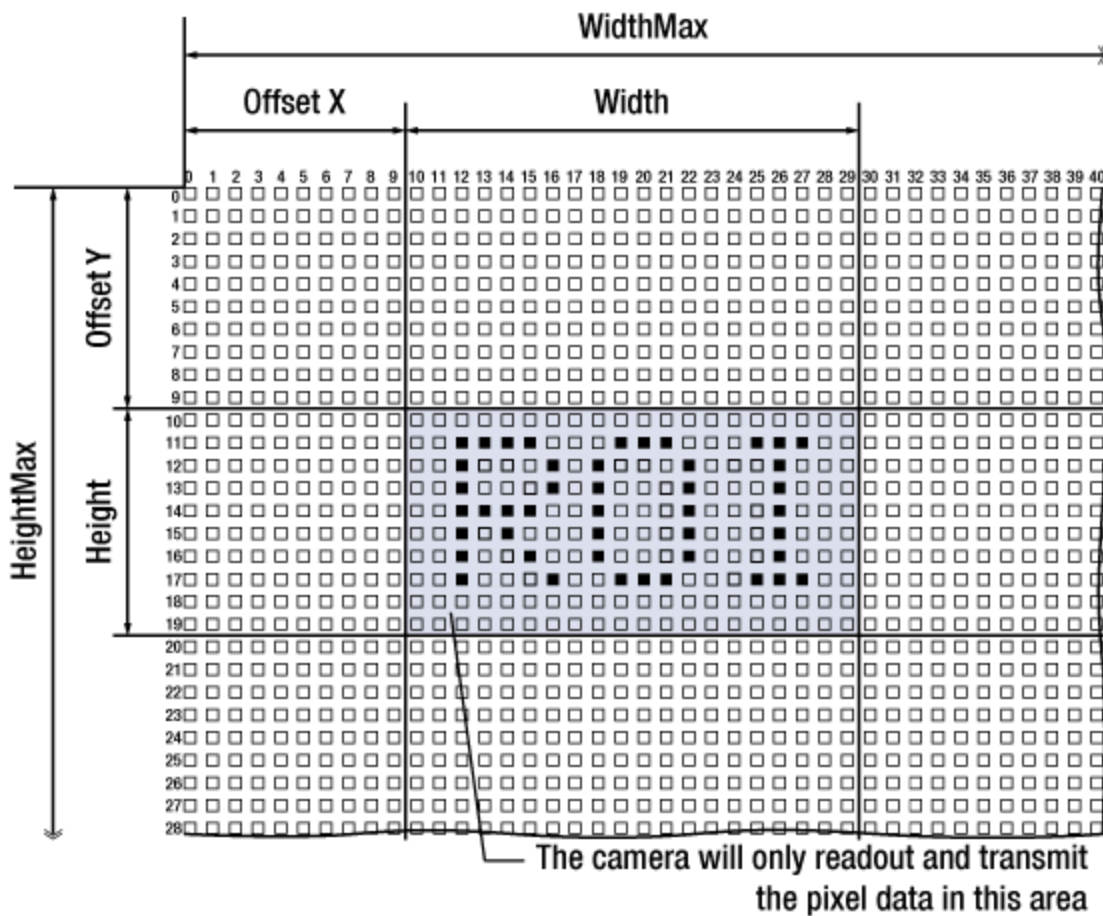

Figure 9.1 Image Region of Interest

The XML parameters related to ROI settings are as follows.

XML Parameters		Value	Description
ImageFormatControl	SensorWidth <sup>a</sup>	-	Effective width of the sensor
	SensorHeight <sup>a</sup>	-	Effective height of the sensor
	WidthMax	-	Maximum allowed width of the image with the current camera settings
	HeightMax	-	Maximum allowed height of the image with the current camera settings
	Width <sup>b</sup>	-	Current width of the image
	Height <sup>b</sup>	-	Current height of the image
	OffsetX <sup>c</sup>	-	Horizontal offset from the origin to the Image ROI
	OffsetY <sup>c</sup>	-	Vertical offset from the origin to the Image ROI

The unit for all parameters in this table is pixel

a: Read only. User cannot change the value

b: User configurable parameters for setting ROI

c: User configurable parameters for setting the origin of the ROI

**Table 9.1 XML parameters related to ROI**

You can change the size of ROI by setting the **Width** and **Height** parameters under the **Image Format Control** category. And also, you can change the position of the ROI origin by setting the **Offset X** and **Offset Y** parameters.

Make sure that the **Width** + **Offset X** value is less than the **Width Max** value, and the **Height** + **Offset Y** value is less than the **Height Max** value. You must set the size of the ROI first, and then set the Offset values since the **Width** and **Height** parameters are set to its maximum value by default.

- On the **VP-50MX** camera, the **Width** parameter must be set to a multiple of 16, and the **Height** parameter must be set to a multiple of 4.

The minimum allowed setting values for the ROI Width and Height are shown below.

Camera Model	Minimum Width Settings	Minimum Height Settings
VP-50MX	384	4

**Table 9.2 Minimum ROI Width and Height Settings**



On the VP-50MX camera, the maximum frame rates depending on Vertical ROI changes are shown below.

ROI Size (H × V)	1 Channel	2 Channels	4 Channels
7920 × 100	402 fps	747 fps	1307 fps
7920 × 1000	45 fps	91 fps	179 fps
7920 × 2000	23 fps	46 fps	91 fps
7920 × 3000	15 fps	30 fps	61 fps
7920 × 4000	11 fps	23 fps	46 fps
7920 × 5000	9 fps	18 fps	37 fps
7920 × 6004	7 fps	15 fps	30 fps

**Table 9.3 Maximum Frame Rates by VP-50MX ROI Changes**

## 9.2 Binning

The Binning has the effects of increasing the level value and decreasing resolution by summing the values of the adjacent pixels and sending them as one pixel. The XML parameters related to Binning are as follows.

XML Parameters		Value	Description
ImageFormatControl	BinningHorizontalMode	Sum	Updated automatically according to the Binning Vertical Mode
		Average	
	BinningHorizontal	×1, ×2, ×4	Updated automatically according to the Binning Vertical
	BinningVerticalMode	Sum	Sum the adjacent pixels as many as specified by the Binning Vertical setting value, and then send them as one pixel.
		Average	Sum the adjacent pixels as many as specified by the Binning Vertical setting value and divide them by the number of summed pixels, and then send them as one pixel.
BinningVertical	×1, ×2, ×4	Number of vertical pixels to combine together	

**Table 9.4 XML Parameters related to Binning**

For example, if you set  $2 \times 2$  binning, the camera's resolution is reduced to  $1/4$ . If you set the **Binning Mode** to **Sum**, the maximum allowed resolution of the image is reduced  $1/2$  and the responsivity of the camera is quadrupled. If you set the **Binning Mode** to **Average**, the maximum allowed resolution of the image is reduced to  $1/2$ , but there is no difference in responsivity between a binned image and an original image. The **Width Max** and **Height Max** parameters, indicating the maximum allowed resolution of the image with the current camera settings, will be updated depending on the binning settings. And also, the **Width**, **Height**, **Offset X** and **Offset Y** parameters will be updated depending on the binning settings. You can verify the current resolution through the **Width** and **Height** parameters.

To apply the binning feature on the VP-50MX camera, you need to set the **Binning Vertical Mode** and **Binning Vertical** parameters. According to these values, the **Binning Horizontal Mode** and **Binning Horizontal** parameters will be updated automatically. The available settings for the binning feature are as follows.

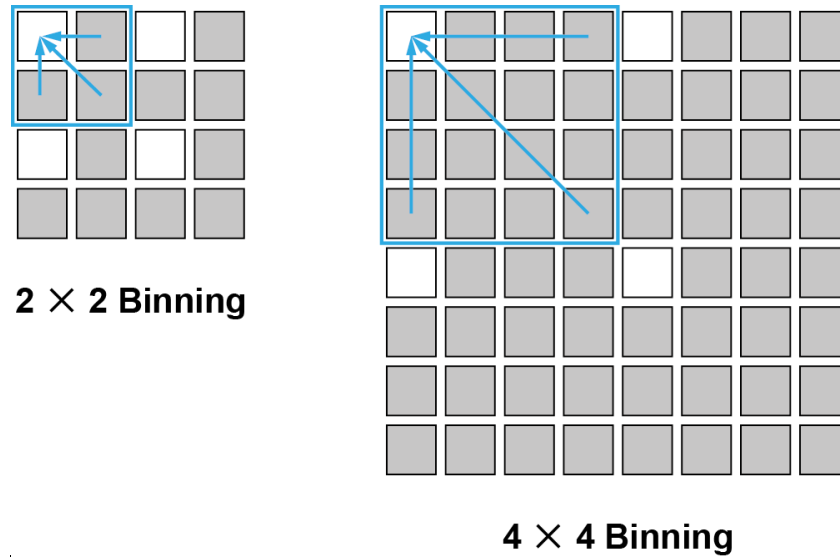

Figure 9.2 2 × 2 and 4 × 4 Binning



The color camera does not support the Binning feature.

### 9.3 CXP Link Configuration

The VP-50MX camera must be connected to a CXP Frame Grabber installed in your computer via CoaXPress interface. CoaXPress interface allows you to connect a camera to a CXP Frame Grabber by using simple coax cabling and allows up to 6.25 Gbps data rate per cable. The VP-50MX camera supports one master connection and up to three extension connections to configure a link. In compliance with the CoaXPress standard, the VP-50MX camera includes an automatic link detection mechanism to correctly detect the camera to CXP Frame Grabber connections.

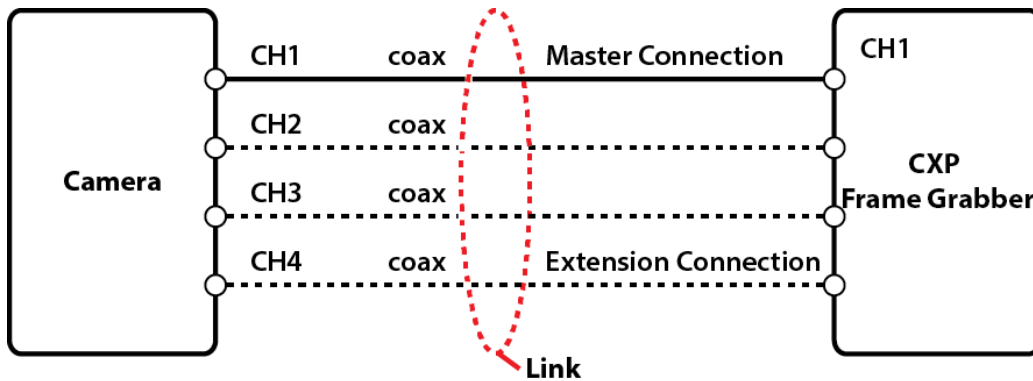

Figure 9.3 CXP Link Configuration

The XML parameters related to the link configuration between the camera and CXP Frame Grabber are located in the CoaXPress category under the Transport Layer Control as shown below.

XML Parameters		Value	Description
CoaXPress	CxpLinkConfigurationPreferredSwitch	CXP6_X1	Sets the <b>A</b> parameter value to CXP6_X1.
		CXP6_X2	Sets the <b>A</b> parameter value to CXP6_X2.
		CXP6_X4	Sets the <b>A</b> parameter value to CXP6_X4.
	CxpLinkConfigurationPreferred <sup>A</sup>	Read Only	Displays bit rate and the number of connections to be set for the link configuration between the camera and Host (Frame Grabber) while discovering devices.
CXPLinkConfiguration	CXP6_X1 CXP6_X2 CXP6_X4	Forcefully sets bit rate and the number of connections for the link configuration. ex) CXP6_X4: Four connections running at a maximum of CXP6 speed (6.25 Gbps)	

Table 9.5 XML Parameter related to CXP Link Configuration

## 9.4 Pixel Format

The camera processes image data in the unit of 12 bit. You can determine the pixel format (8 bits, 10 bits or 12 bits) of these image data transmitted from the camera by selecting the **Pixel Format** parameter. When the camera is set for 8 bit or 10 bit pixel format, the least 4 or 2 least significant bits will be dropped from overall 12 bits.

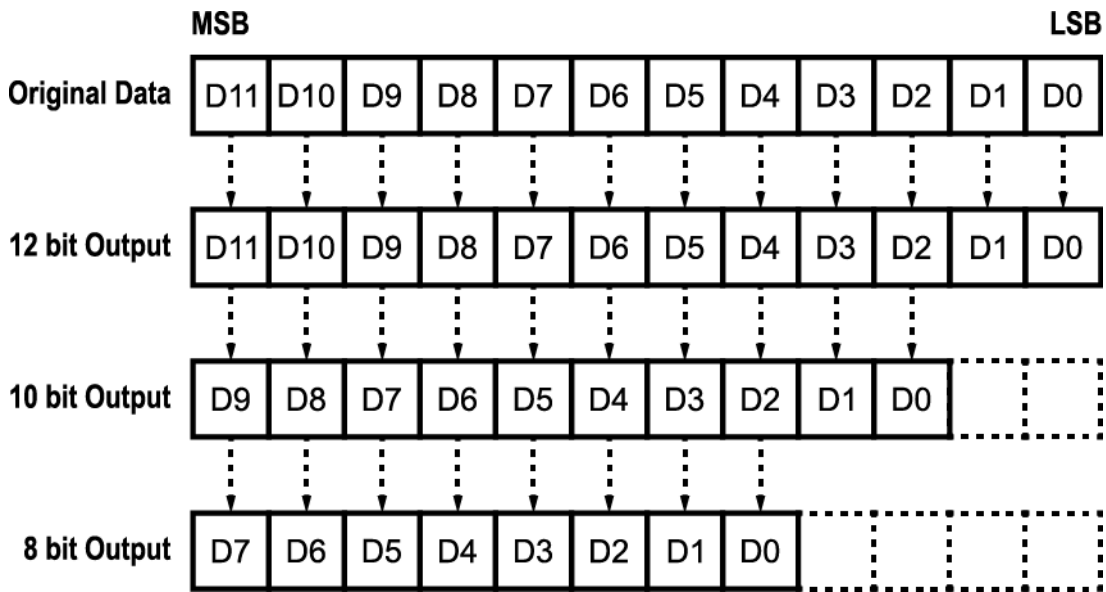

Figure 9.4 Pixel Format

The XML parameter related to the Pixel Format is as follows.

XML Parameters		Description
ImageFormatControl	PixelFormat	Sets the pixel format supported by the device.

Table 9.6 XML Parameter related to Pixel Format

The available pixel format on the monochrome and color cameras are as follows.

Mono Sensor	Color Sensor
<ul style="list-style-type: none"> <li>• Mono 8</li> <li>• Mono 10</li> <li>• Mono 12</li> </ul>	<ul style="list-style-type: none"> <li>• Mono 8</li> <li>• Mono 10</li> <li>• Mono 12</li> <li>• Bayer BG 8</li> <li>• Bayer BG 10</li> <li>• Bayer BG 12</li> </ul>

Table 9.7 Pixel Format Values

## 9.5 Data ROI (Color Camera)

The **Balance White Auto** feature provided by the color camera uses the pixel data from a Data Region of Interest (ROI) to adjust the related parameters. The XML parameters related to Data ROI are as follows.

XML Parameters		Value	Description
DataRoiControl	RoiSelector	WhiteBalanceAuto	<ul style="list-style-type: none"> <li>Selects a Data ROI used for Balance White Auto</li> <li>Only available on the color camera</li> </ul>
	RoiOffsetX	-	X coordinate of start point ROI
	RoiOffsetY	-	Y coordinate of start point ROI
	RoiWidth	-	Width of ROI
	RoiHeight	-	Height of ROI

Table 9.8 XML Parameters related to Data ROI

Only the pixel data from the area of overlap between the data ROI by your settings and the Image ROI will be effective if you use Image ROI and Data ROI at the same time. The effective ROI is determined as shown in the figure below.

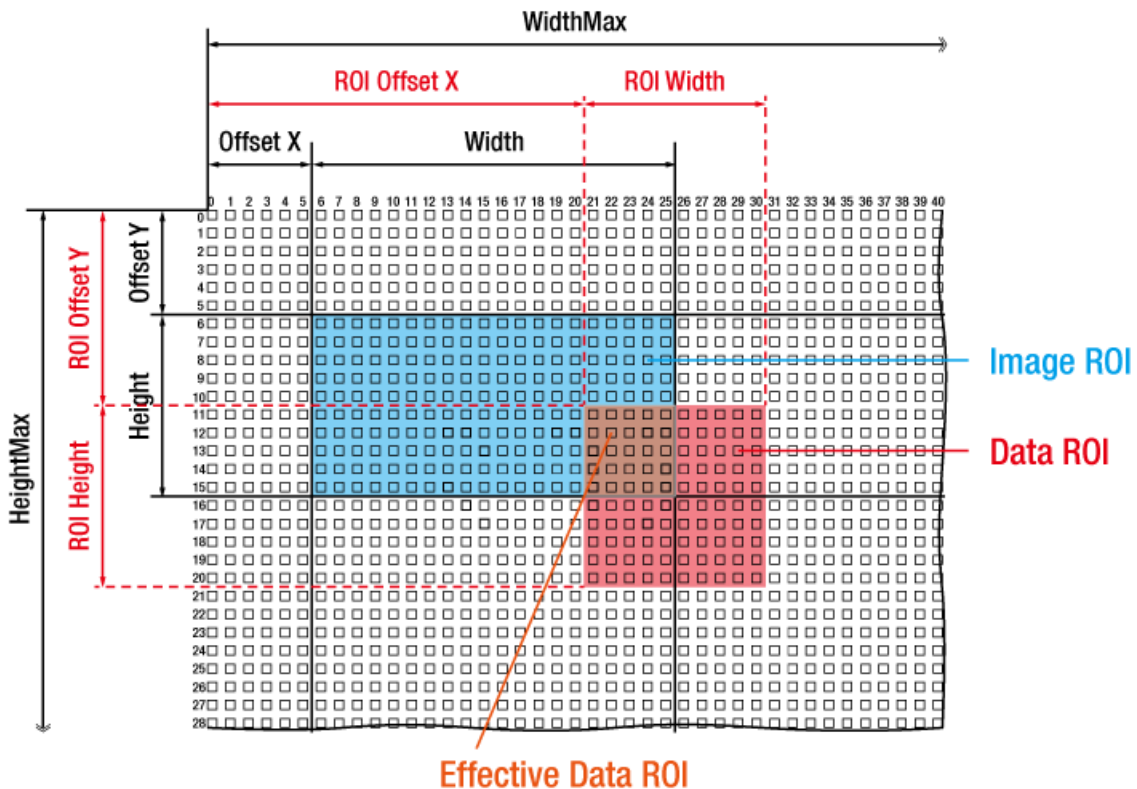

Figure 9.5 Effective Data ROI

## 9.6 White Balance (Color Camera)

The color camera includes the white balance capability to adjust the color balance of the images transmitted from the camera. With the white balancing scheme used on the VP-50MX camera, the Red intensity and Blue intensity can be adjusted individually. You can set the intensity of each color by using the **Balance Ratio** parameter. The Balance Ratio value can range from 1.0 to 4.0. If the **Balance Ratio** parameter is set to 1.0 for a color, the intensity of the color will be unaffected by the white balance mechanism. If the **Balance Ratio** is set to greater than 1.0, the intensity of the color will be proportionally increased to the ratio. For example, if the Balance Ratio is set to 1.5, the intensity of that color will be increased by 50%.

The XML parameters related to White Balance are as follows.

XML Parameters		Value	Description
AnalogControl	BalanceRatioSelector	Red	A Balance Ratio value will be applied to red pixels.
		Blue	A Balance Ratio value will be applied to blue pixels.
	BalanceRatio	×1.0 ~ ×4.0	Controls ratio of the selected color by referring to Green.

Table 9.9 XML Parameters related to White Balance

### 9.6.1 Balance White Auto

The **Balance White Auto** feature is implemented on the color camera. It will control the white balance of the image acquired from the color camera according to the GeryWorld algorithm. Before using the **Balance White Auto** feature, you need to set the Data ROI for Balance White Auto. If you do not set the related Data ROI, the pixel data from the Image ROI will be used to control the white balance. As soon as the **Balance White Auto** parameter is set to **Once**, the Balance Ratio values for Red and Blue will be automatically adjusted to adjust the white balance by referring to Green. The XML parameters related to Balance White Auto are as follows.

XML Parameters		Value	Description
AnalogControl	BalanceWhiteAuto	Off	Balance White Auto Off
		Once	White Balance is adjusted once and then Off.

Table 9.10 XML Parameters related to Balance White Auto

## 9.7 Gain and Black Level

Increasing the **Gain** parameter increases the slope of the camera's response curve as shown in the figure below. This results in a higher grey value output from the camera for a given amount of output from the imaging sensor.

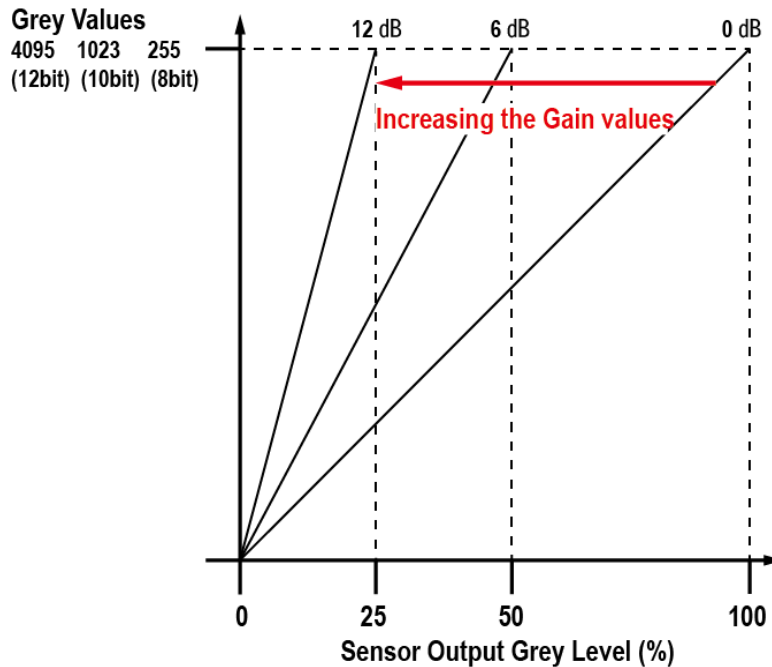

Figure 9.6 Setting the Gain

Adjusting the **Black Level** parameter will result in an offset to the pixel values output from the camera. The XML parameters related to Gain and Black Level are as follows.

XML Parameters		Value	Description
AnalogControl	AnalogGain	×1, ×2, ×4	Sets an analog gain value.
	DigitalGain	×1.0 ~ ×30.0	Sets a digital gain value.
	BlackLevelSelector	DigitalAll	Applies black level to all digital channels.
	BlackLevel	0 ~ 256	Sets a black level value.

Table 9.11 XML Parameters related to Gain and Black Level



## 9.8 Defective Pixel Correction

The CMOS sensor may have Defect Pixels which cannot properly react to the light. Correction is required since it may deteriorate the quality of output image. Defect Pixel information of CMOS used for each camera is entered into the camera during the manufacturing process. If you want to add Defect Pixel information, it is required to enter coordinate of new Defect Pixel into the camera. For more information, refer to [Appendix A](#).

### 9.8.1 Correction Method

A correction value for a Defect Pixel is calculated based on the valid pixel value adjacent in the same line.

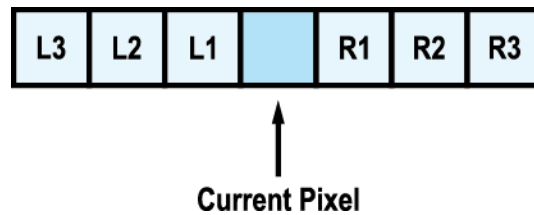

**Figure 9.7 Location of Defect Pixel to be corrected**

If the Current Pixel is a Defect Pixel as shown in the figure above, the correction value for this pixel is obtained as shown in the following table depending on whether surrounding pixels are Defect Pixels or not.

Adjacent Defect Pixel (s)	Correction Value of Current Pixel
None	$(L1 + R1) / 2$
L1	R1
R1	L1
L1, R1	$(L2 + R2) / 2$
L1, R1, R2	L2
L2, L1, R1	R2
L2, L1, R1, R2	$(L3 + R3) / 2$
L2, L1, R1, R2, R3	L3
L3, L2, L1, R1, R2	R3

**Table 9.12 Calculation of Defect Pixel Correction Value**



You must download a Defect Pixel Map to the camera before using the **Defective Pixel Correction** feature. For more information about how to download a Defect Pixel to the camera, refer to [Appendix A](#).

## 9.9 Flat Field Correction

The Flat Field Correction feature improves the image uniformity when you acquire a non-uniformity image due to external conditions. The Flat Field Correction feature of the VP-50MX camera can be summarized by the following equation:

$$IC = IR / IF$$

Where,

IC: Level value of corrected image;

IR: Level value of original image;

IF: Level value of Flat Field data.

In actual use conditions, generate a Flat Field data (IF) and apply the Flat Field Correction feature by following the procedures below.

1. Execute the **Flat Field Data Generate** parameter.  
After executing the **Flat Field Data Generate** parameter, you must acquire one image to generate the scaled down Flat Field data.
2. Before saving the generated Flat Field data, you can choose a location to store the data by using the **Flat Field Data Selector** parameter.
3. Execute the **Flat Field Data Save** parameter to save the generated Flat Field data into the non-volatile memory. When the scaled down Flat Field data are used for corrections, they are expanded and applied with a Bilinear Interpolation as shown in the Figure 9.9.



- It is recommended that you enable the **Defective Pixel Correction** feature before executing the **Flat Field Data Generate** parameter.
- Before executing the **Flat Field Data Generate** parameter, you must set the camera as follows:
  - OffsetX, Y: 0
  - Width, Height: Maximum values
  - Binning: ×1
- After executing an **Acquisition Start** command, you need to operate the camera with free-run mode or apply a trigger signal to acquire an image.

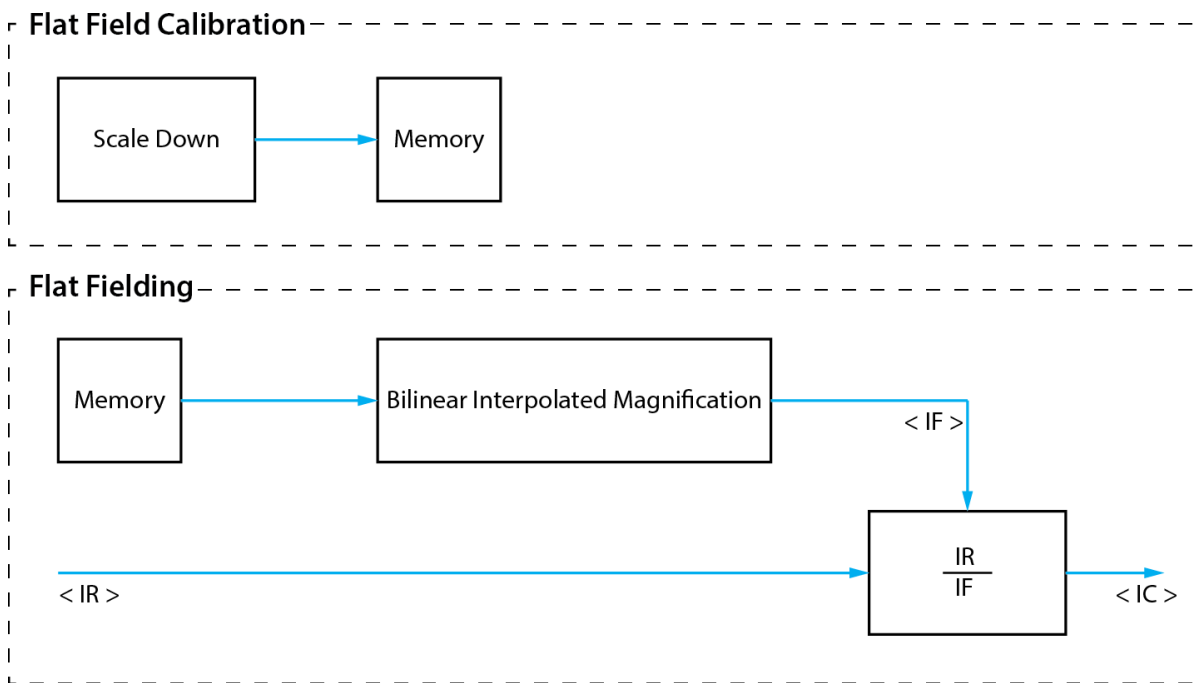

Figure 9.8 Generation and Application of Flat Field Data

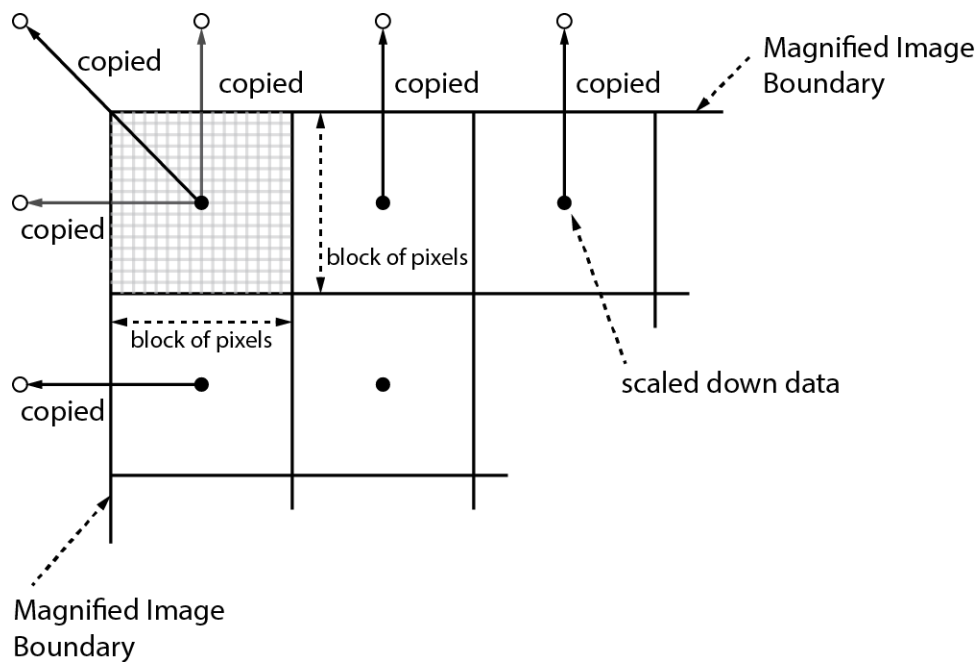

Figure 9.9 Bilinear Interpolated Magnification

The XML parameters related to Flat Field Correction are as follows.

XML Parameters		Value	Description
FlatFieldCorrection	FlatFieldDataSelector	0 ~ 4	Selects a location to save Flat Field data to or load Flat Field data from. <ul style="list-style-type: none"> <li>• 0: Factory default location</li> <li>• 1 ~ 4: User defined locations</li> </ul>
	FlatFieldDataGenerate	–	Generates the Flat Field data.
	FlatFieldDataSave	–	Saves the generated Flat Field data in the non-volatile memory. <ul style="list-style-type: none"> <li>• The generated data by executing the <b>Flat Field Data Generate</b> parameter are saved in the volatile memory so that the data are lost if the camera is reset or if power is turned off. To use the data after the camera is powered on or reset, save them in the non-volatile memory.</li> </ul>
	FlatFieldDataLoad	–	Loads the Flat Field data from the non-volatile memory into volatile memory.

**Table 9.13 XML Parameters related to Flat Field Correction**

## 9.9.1 Flat Field Data Selector

As mentioned above, the active Flat Field data is stored in the camera's volatile memory and the data is lost if the camera is reset or powered off. To use the active or generated Flat Field data after the camera is powered on or reset, you need to save them in the camera's non-volatile memory. The VP-50MX camera provides four reserved locations in the camera's non-volatile memory available for saving the active Flat Field data and five reserved locations in the camera's non-volatile memory available for loading the saved Flat Field data into the camera's active Flat Field data. You can use the **Flat Field Data Selector** parameter to select a location as desired. The factory default Flat Field data are saved into each location during the manufacturing process.

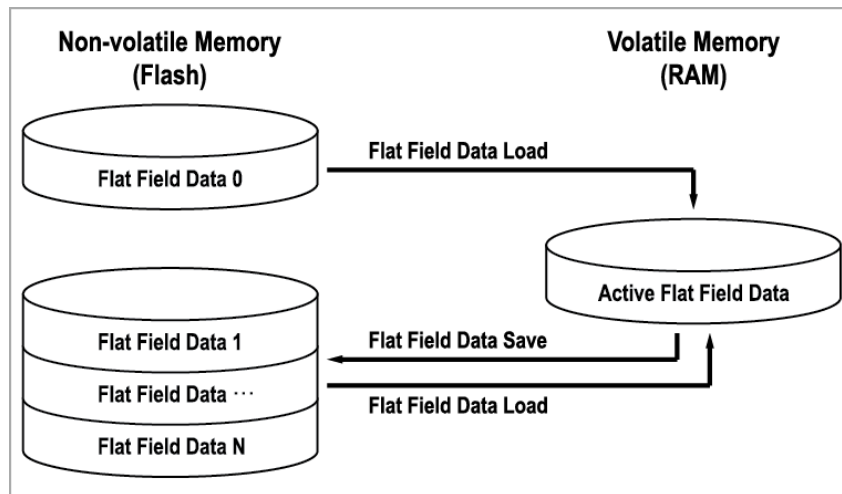

Figure 9.10 Flat Field Data Selector

### Saving Flat Field Data

In order to save the generated active Flat Field data into a reserved location in the camera's flash memory, follow the procedures below.

1. Use the **Flat Field Data Selector** parameter to specify a location to save the active Flat Field data.
2. Execute the **Flat Field Data Save** parameter to save the active Flat Field data to the selected location.

### Loading Flat Field Data

If you saved a Flat Field data into the camera's non-volatile memory, you can load the saved Flat Field data from the camera's non-volatile memory into the camera's active Flat Field data location.

1. Use the **Flat Field Data Selector** parameter to specify a reserved location whose Flat Field data will be loaded into the camera's active Flat Field data location.
2. Execute the **Flat Field Data Load** parameter to load the selected Flat Field data into the active Flat Field data location.

## 9.10 Temperature Monitor

The camera has an embedded sensor chip to monitor the internal temperature.

The XML parameters related to Device Temperature are as follows.

XML Parameters		Value	Description
DeviceControl	DeviceTemperatureSelector	Sensor	Sets a temperature measuring spot to the image sensor.
		Mainboard	Sets a temperature measuring spot to the mainboard.
	DeviceTemperature	-	Displays device temperature in Celsius.

**Table 9.14 XML Parameter related to Device Temperature**

## 9.11 Status LED

A LED is installed on the back panel of the camera to inform the operation status of the camera. LED status and corresponding camera status are as follows:

Status LED	Description
Steady Red	The camera is not initialized.
Slow Flashing Red	A CXP link is not configured.
Fast Flashing Orange	The camera is checking a CXP link configuration.
Steady Green	A CXP link is configured.
Fast Flashing Green	The camera is transmitting image data.

**Table 9.15 Status LED**

## 9.12 Test Pattern

To check whether the camera operates normally or not, it can be set to output test patterns generated in the camera, instead of image data from the image sensor. Three types of test patterns are available; image with different value in horizontal direction (Grey Horizontal Ramp), image with different value in diagonal direction (Grey Diagonal Ramp), and moving image with different value in diagonal direction (Grey Diagonal Ramp Moving).

The XML parameter related to Test Pattern is as follows.

XML Parameters		Value	Description
ImageFormatControl	TestPattern	Off	Test Pattern Off
		GreyHorizontalRamp	Sets to Grey Horizontal Ramp.
		GreyDiagonalRamp	Sets to Grey Diagonal Ramp.
		GreyDiagonalRampMoving	Sets to Grey Diagonal Ramp Moving.

**Table 9.16 XML Parameter related to Test Pattern**

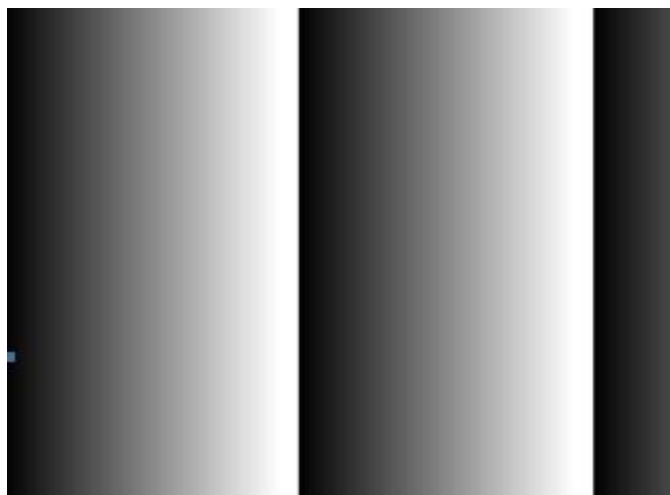

**Figure 9.11 Grey Horizontal Ramp**

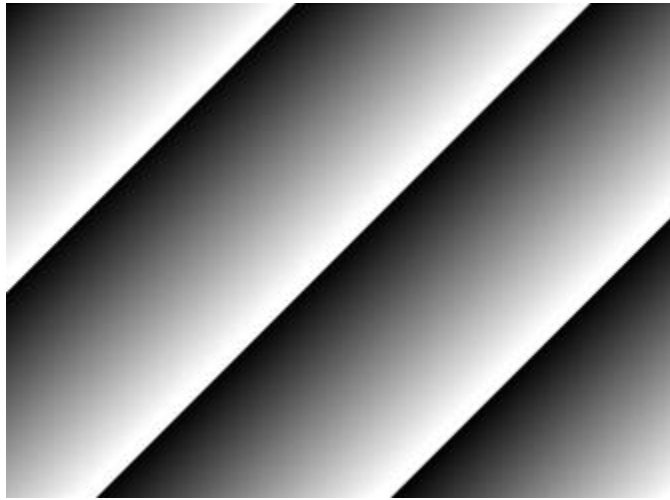

**Figure 9.12 Grey Diagonal Ramp**

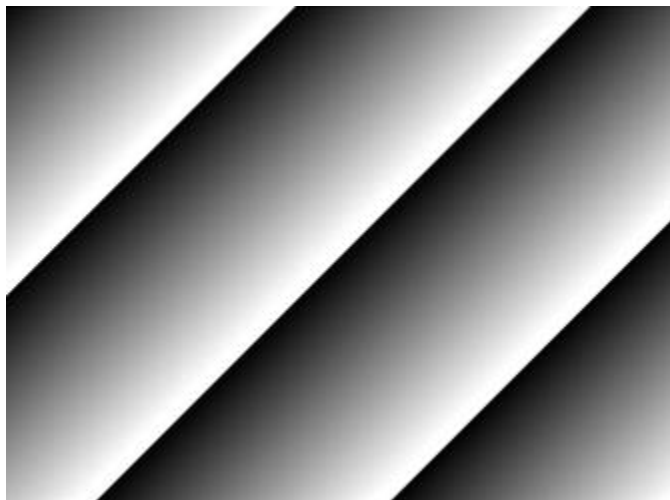

**Figure 9.13 Grey Diagonal Ramp Moving**



The test pattern may look different because the region of the test pattern may vary depending on the camera's resolution.



## 9.13 Reverse X

The Reverse X feature lets you flip images horizontally. This feature is available in all operation modes of the camera.



Figure 9.14 Original Image

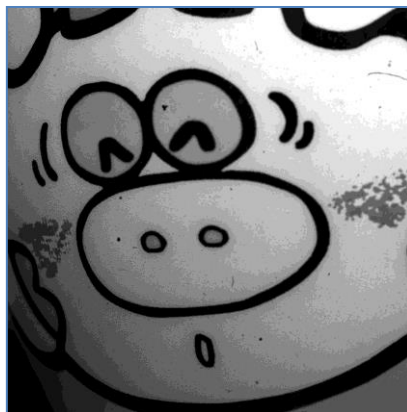

Figure 9.15 Reverse X Image



When you enable the **Reverse X** feature with the **Pixel Format** parameter set to **Bayer** on a color camera, the alignment of the color filter will be changed.

## 9.14 Digital IO Control

The control I/O receptacle of the camera can be operated in various modes.

The XML parameters related to Digital IO Control are as follows.

XML Parameters		Value	Description
DigitalIOControl	LineSelector	LineOut0	Selects the number 4 pin of the camera's control I/O receptacle as an output line.
	LineInverter	FALSE	Disables inversion of the output signal of the line.
		TRUE	Enables inversion of the output signal of the line.
	LineSource	Off	Disables the line output.
		ExposureActive	Outputs pulse signals indicating the current exposure time.
		FrameActive	Outputs pulse signals indicating a frame readout time.
		UserOutput	Outputs pulse signals set by the UserOutputValue parameter.
	UserOutputValue	FALSE	Sets the bit state of the line to Low.
		TRUE	Sets the bit state of the line to High.
	DebounceTime	0 – 1,000,000 $\mu$ s	Sets a Debounce Time value in microseconds (Default: 0.5 $\mu$ s)

**Table 9.17 Digital IO Control**

When you set the **Line Source** to **User Output**, you can use the user setting value as output signals.

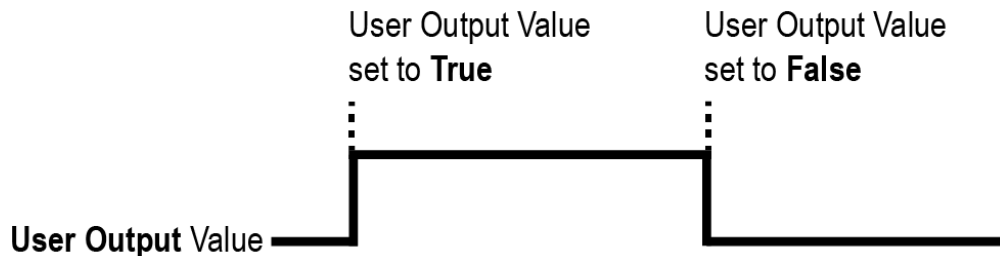

**Figure 9.16 User Output**

The camera can provide an Exposure Active output signal. The signal goes high when the exposure time for each frame acquisition begins and goes low when the exposure time ends as shown in the figure below. This signal can be used as a flash trigger and is also useful when you are operating a system where either the camera or the object being imaged is movable. Typically, you do not want the camera to move during exposure. You can monitor the Exposure Active signal to know when exposure is taking place and thus know when to avoid moving the camera.

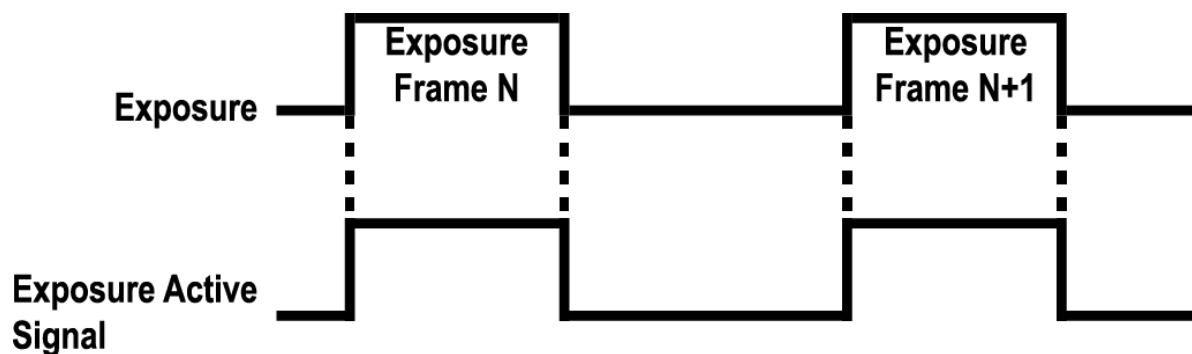

Figure 9.17 Exposure Active Signal

### 9.14.1 Debounce

The Debounce feature of the VP-50MX camera allows to supply only valid signals to the camera by discriminating between valid and invalid input signals. The **Debounce Time** parameter specifies the minimum time that an input signal must remain High or Low in order to be considered as a valid input signal. When you use the Debounce feature, be aware that there is a delay between the point where the valid input signal arrives and the point where the signal becomes effective. The duration of the delay is determined by the Debounce Time parameter setting value. When you set the **Debounce Time** parameter, High and Low signals shorter than the setting value are considered invalid and ignored as shown in the figure below.

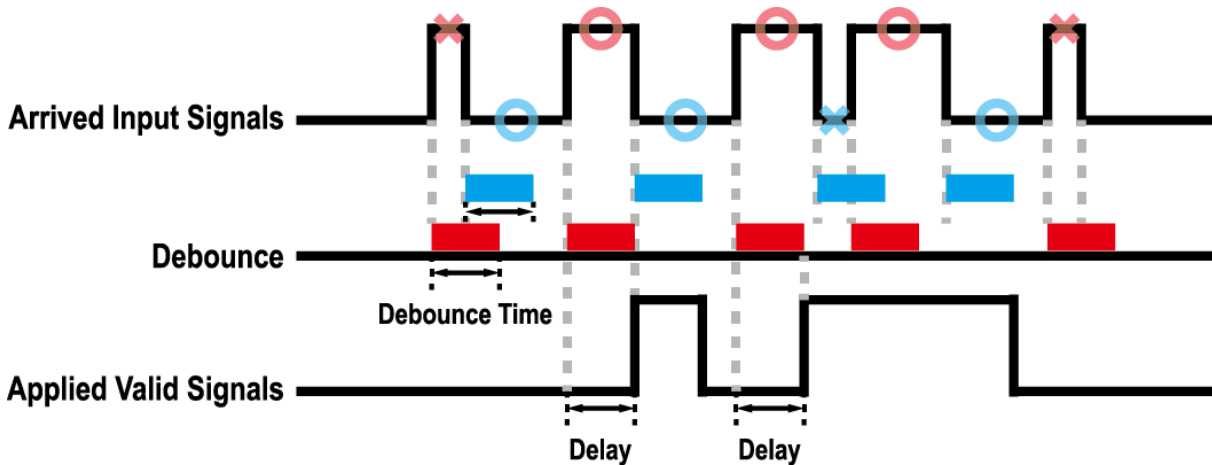

Figure 9.18 Debounce

The XML parameter related to Debounce is as follows.

XML Parameters		Value	Description
DigitalIOControl	Debounce Time	0 – 1,000,000 $\mu$ s	Sets a Debounce Time value in microseconds (Default: 0.5 $\mu$ s).

Table 9.18 XML Parameter related to Debounce Time

## 9.15 Counter and Timer Control

When the **Line Source** parameter in the **Digital IO Control** category is set to **Timer0 Active**, the camera can provide output signals by using the Timer. The VP-50MX camera has one Timer designated as Timer0 and exposure start is the only trigger source event available to start the Timer.

The XML parameters related to Counter and Timer Control are as follows.

XML Parameters		Value	Description
CounterAndTimerControl	TimerDuration	1 – 60,000,000 $\mu$ s	Sets the duration of the Timer output signal.
	TimerDelay	0 – 60,000,000 $\mu$ s	Sets the delay time to be applied before starting the Timer.
	TimerReset	-	Resets the Timer and starts it again.
	TimerTriggerSource	Off	Disables the Timer trigger.
		Exposure	Sets the Timer to use the exposure start as source signals.
	TimerTriggerActivation	Falling Edge	Specifies that a falling edge of the selected trigger signal will act as the Timer trigger.
		Rising Edge	Specifies that a rising edge of the selected trigger signal will act as the Timer trigger.
		Level Low	Specifies that the Timer output signal will be valid as long as the selected trigger signal is Low.
		Level High	Specifies that the Timer output signal will be valid as long as the selected trigger signal is High.

**Table 9.19 XML Parameters related to Counter and Timer Control**

For example, when the **Timer Trigger Activation** is set to **Level High**, the Timer will act as follows:

1. When source signals set by the **Timer Trigger Source** (Exposure is only available) are applied, the Timer will start operations.
2. The delay set by the **Timer Delay** begins to expire.
3. When the delay expires, the Timer signal goes high as long as the source signal is high.

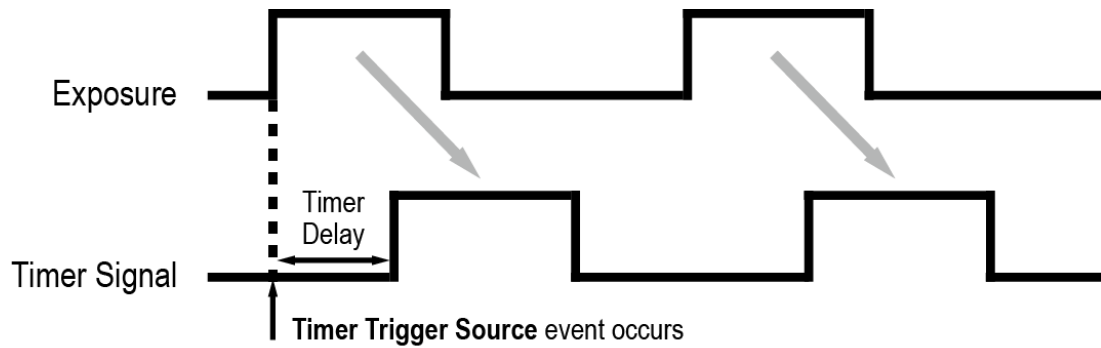

\* **Timer Trigger Activation** is set to **Level High**.

**Figure 9.19** Timer Signal

## 9.16 Cooling Control

A fan is installed on the rear panel of the camera and Thermoelectric Peltier is installed inside the camera to control the image sensor temperature. You can set the fan and Peltier to turn on or off. You can also set the Peltier to turn on when a specified internal temperature is reached.

The XML parameters related to Cooling Control are as follows.

XML Parameters		Value	Description
CoolingControl	FanOperationMode	Off	Turns off the fan.
		On	Turns on the fan.
	TargetTemperature	-10°C~80°C	Sets the target temperature to operate the Thermoelectric Peltier.
	FanSpeed	-	Displays the current Fan RPM.
	PeltierOperationMode	Off	Turns off the Thermoelectric Peltier.
On		Turns on the Thermoelectric Peltier when the internal temperature exceeds the value set in the Target Temperature parameter.	

**Table 9.20 XML Parameters related to Cooling Control**

## 9.17 Device User ID

You can input user defined information up to 16 bytes.

The XML parameter related to Device User ID is as follows.

XML Parameters		Description
DeviceControl	DeviceUserID	Input user defined information (16byte).

**Table 9.21 XML Parameter related to Device User ID**

## 9.18 Device Reset

Resets the camera physically to power off and on. You must configure a link again because the camera will be released from the link between the camera and CXP Frame Grabber after reset.

The XML parameter related to Device Reset is as follows.

XML Parameters		Description
DeviceControl	DeviceReset	Resets the camera physically.

**Table 9.22 XML Parameter related to Device Reset**

## 9.19 User Set Control

You can save the current camera settings to the camera's internal ROM. You can also load the camera settings from the camera's internal ROM. The camera provides two setups to save and three setups to load settings.

The XML parameters related to User Set Control are as follows.

XML Parameters		Value	Description
UserSetControl	UserSetSelector	Default	Selects the Factory Default settings.
		UserSet1	Selects the User Set1 settings.
		UserSet2	Selects the User Set2 settings.
	UserSetLoad	-	Loads the User Set specified by User Set Selector to the camera.
	UserSetSave	-	Saves the current settings to the User Set specified by User Set Selector. <ul style="list-style-type: none"> <li>The Default is a Factory Default Settings and allowed to load only.</li> </ul>
	UserSetDefault	Default	Applies the Factory Default settings when reset.
		UserSet1	Applies the User Set1 when reset.
		UserSet2	Applies the User Set2 when reset.

**Table 9.23 XML Parameters related to User Set Control**



The camera settings stored in the Default can be loaded into the camera's workspace, but cannot be changed. The settings set in the workspace will be lost if the camera is reset or powered off. To use the current setting values in the workspace after a reset, you must save the settings to one of the user spaces.

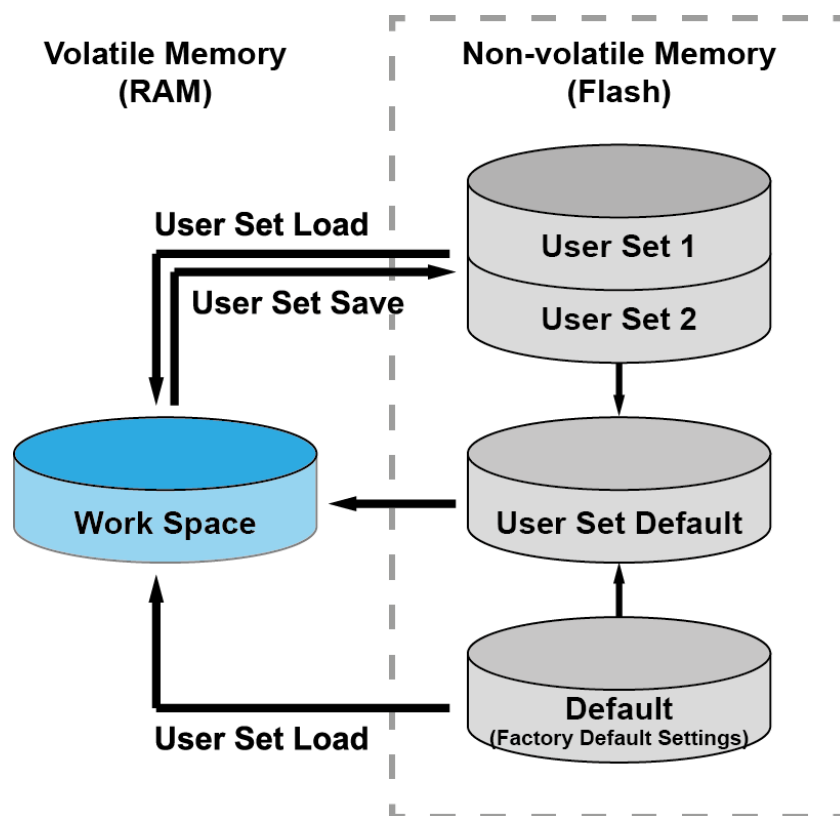

Figure 9.20 User Set Control

## 9.20 Field Upgrade

The camera provides a feature to upgrade the Firmware and FPGA logic through the CoaXPress interface rather than disassemble the camera in the field. Refer to [Appendix B](#) for more details about how to upgrade.

## 10 Troubleshooting

When you have a problem with a Vieworks camera, please check the following:

- If no image is displayed on your computer,
  - Ensure that all the cable connections are secure.
  - Ensure that the power supply is properly connected.
  - Ensure that trigger signal is applied correctly when you set the Trigger Mode parameter to On.
  
- If images are not clear,
  - Ensure the camera lens or glass is clean.
  - Check the lens aperture is adjusted properly.
  
- If images are dark,
  - Ensure your camera lens is not blocked.
  - Check the exposure time is set properly.
  - Check the aperture is opened properly.
  - Check the Gain value is not set too small.
  
- If you identify abnormal operation or overheating sign,
  - Ensure that power supply is properly connected.
  - Stop using the camera when you notice smoke or abnormal overheating.
  
- If you have a problem using the Trigger Mode,
  - Ensure that the Software trigger related parameters are configured correctly.
  - Ensure that the trigger related parameters on your CXP Frame Grabber are configured correctly when you set the Trigger Source parameter to CXPin.
  - Ensure that cable connections are secure when you set the Trigger Source parameter to LineIn0.
  
- If there is a communication failure between the camera and computer,
  - Ensure coax cables are connected properly.
  - Ensure that you have configured a CXP Frame Grabber in your computer correctly and the camera is connected properly to the CXP Frame Grabber.

## Appendix A Defective Pixel Map Download

1. Create the Defect Pixel Map data in Microsoft Excel format as shown in the left picture below and save as a CSV file (\*.csv). The picture in the right shows the created Excel file opened in Notepad. The following rules need to be applied when creating the file.
  - Lines beginning with ':' or '--' are treated as notes.
  - Each row is produced in the order of the horizontal and vertical coordinate values.
  - The input sequence of pixel is irrelevant.

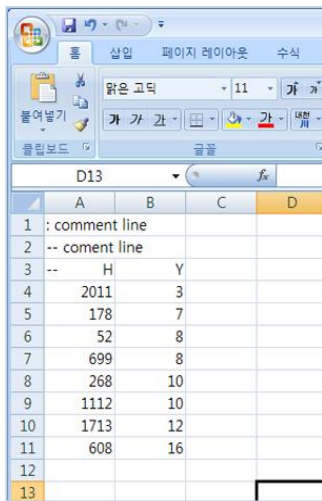

	A	B	C	D
1	:	comment line		
2	--	coment line		
3	--	H	Y	
4		2011	3	
5		178	7	
6		52	8	
7		699	8	
8		268	10	
9		1112	10	
10		1713	12	
11		608	16	
12				
13				

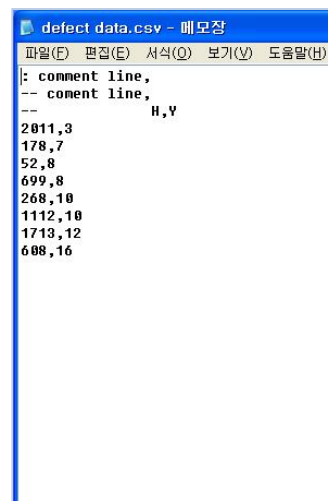

```
defect data.csv - 메모장
파일(F) 편집(E) 서식(O) 보기(V) 도움말(H)
: comment line,
-- coment line,
-- H,Y
2011,3
178,7
52,8
699,8
268,10
1112,10
1713,12
608,16
```

2. Run Vieworks Imaging Solution 7.X and click the **Configure** button to display the window as shown below. Select the **Defect** tab, click the File Path button, search and select the defect pixel map file (\*.csv), and then click the **Download** button.

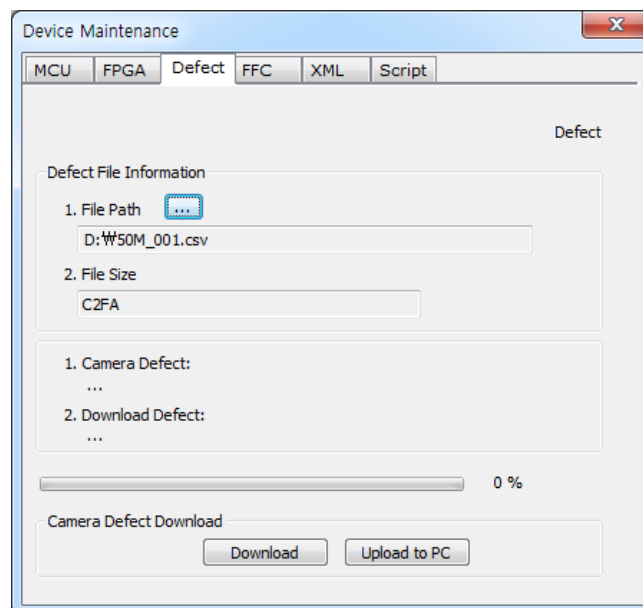

- Once the download is complete, the saving process will begin. During the saving process, make sure not to disconnect the power cord.

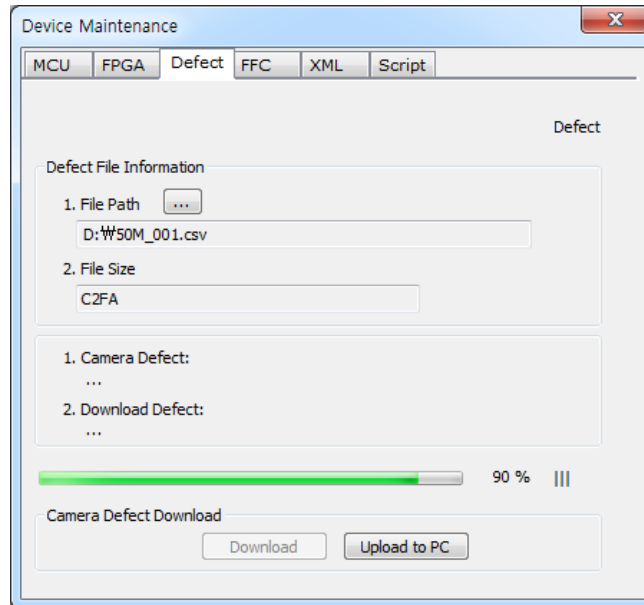

- After completing the download, click the **OK** button to close the confirmation.

## Appendix B Field Upgrade

### B.1 MCU

1. Run Vieworks Imaging Solution 7.X and click the **Configure** button to display the window as shown below.
2. Select the **MCU** tab, click the File Path button, search and select the MCU upgrade file (\*.mcu), and then click the **Download** button.

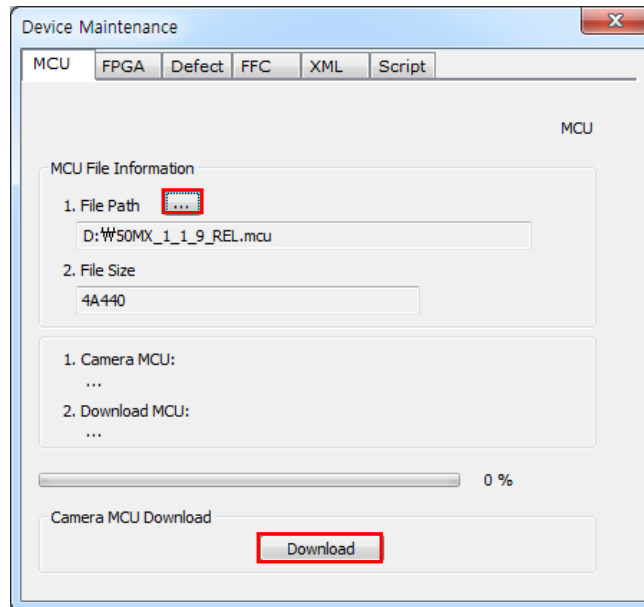

3. MCU upgrade file download starts and the downloading status is displayed at the bottom of the window.

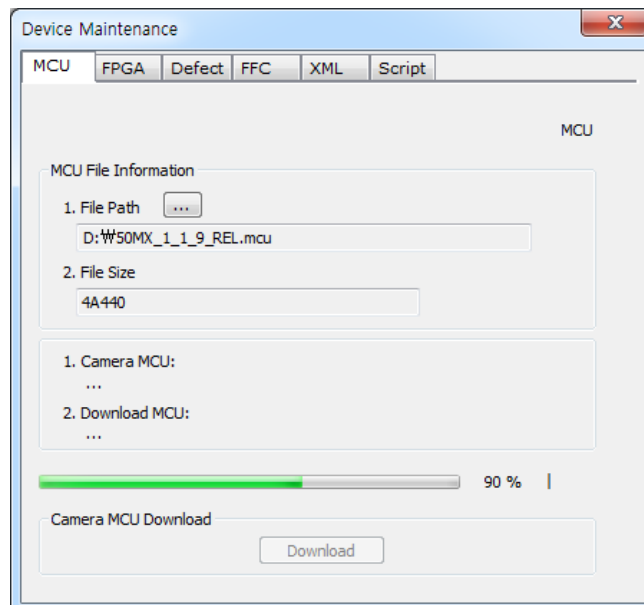

4. Once all the processes have been completed, turn the camera power off and turn it back on again.  
Check the Device Version parameter value to confirm the version.

DeviceVersion	M:1.1.6 F:0.0.7 P
---------------	-------------------

## B.2 FPGA

1. Run Vieworks Imaging Solution 7.X and click the **Configure** button to display the window as shown below.
2. Select the **FPGA** tab, click the File Path button, search and select the FPGA upgrade file (\*.fpga), and then click the **Download** button.

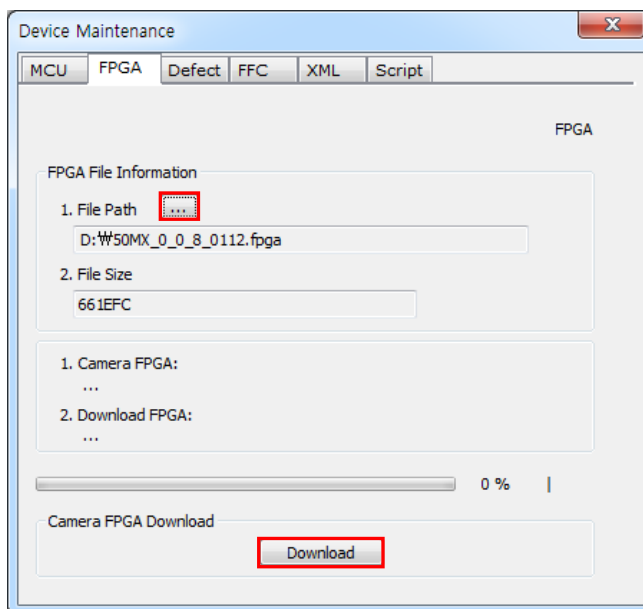

3. The subsequent processes are identical to those of MCU upgrade.

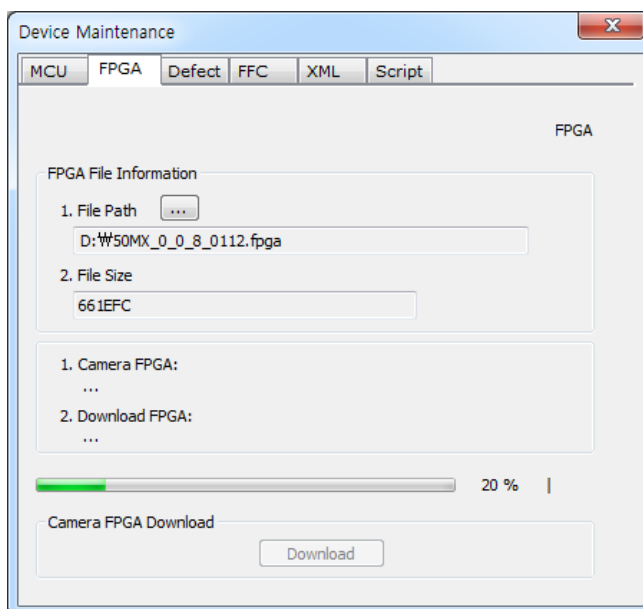

## B.3 XML

1. Run Vieworks Imaging Solution 7.X and click the **Configure** button to display the window as shown below.
2. Select the **XML** tab, click the File Path button, search and select the XML upgrade file (\*.vxf), and then click the **Download** button.

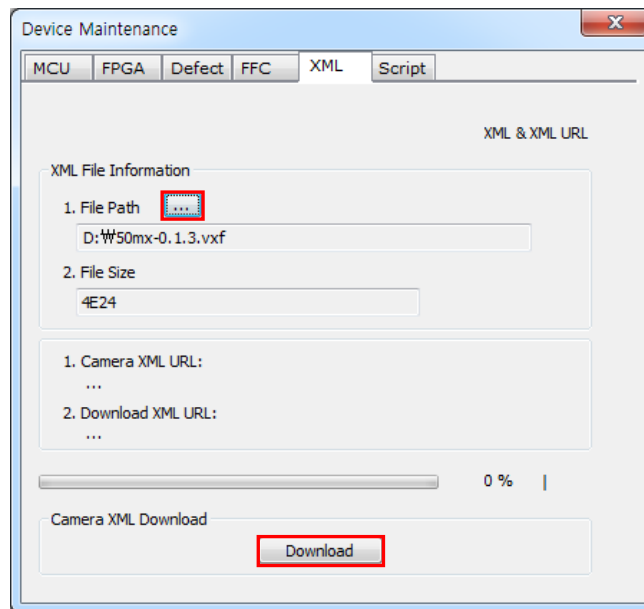

3. The subsequent processes are identical to those of MCU upgrade.

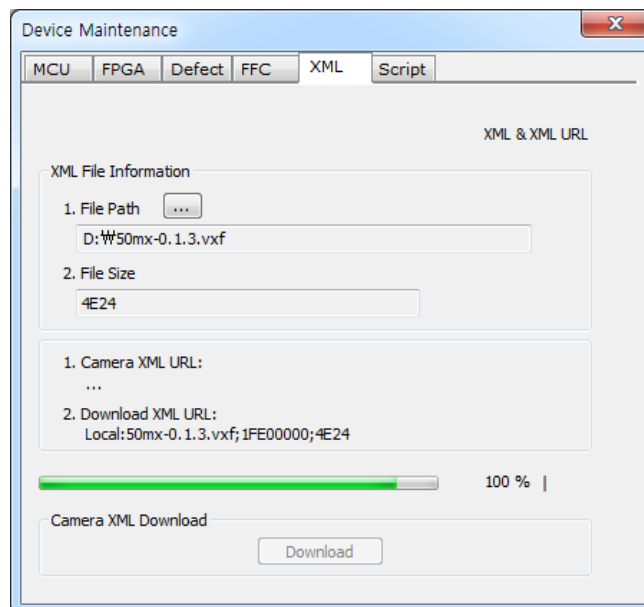



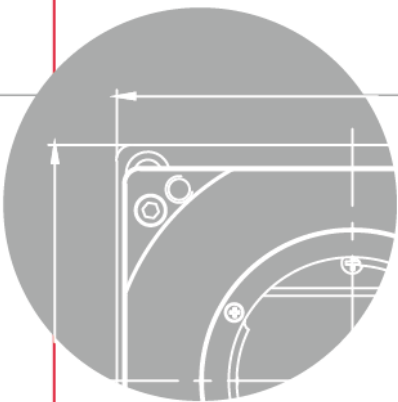
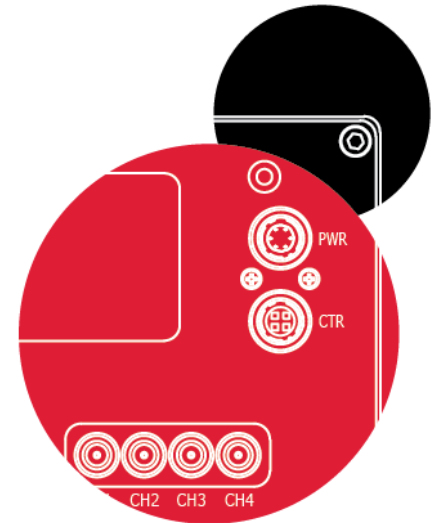
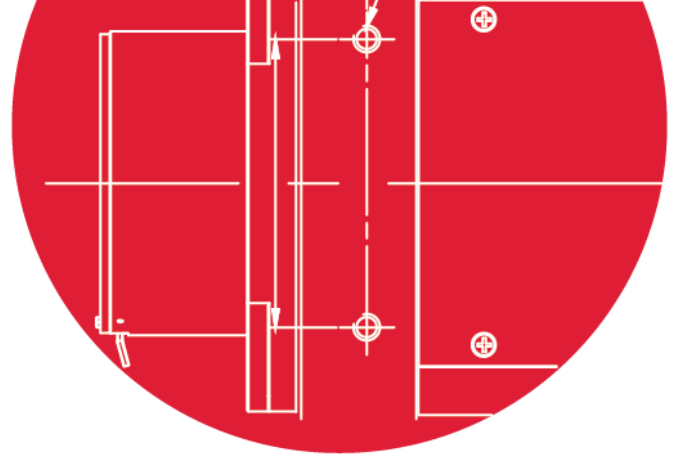

## Vieworks Co., Ltd.

41-3, Burim-ro, 170beon-gil,  
Dongan-gu, Anyang-si, Gyeonggi-do  
14055 Republic of Korea

Tel: +82-70-7011-6161

Fax: +82-31-386-8631

<http://www.vieworks.com>

[vision@vieworks.com](mailto:vision@vieworks.com)