

# VP-71MC

## User Manual

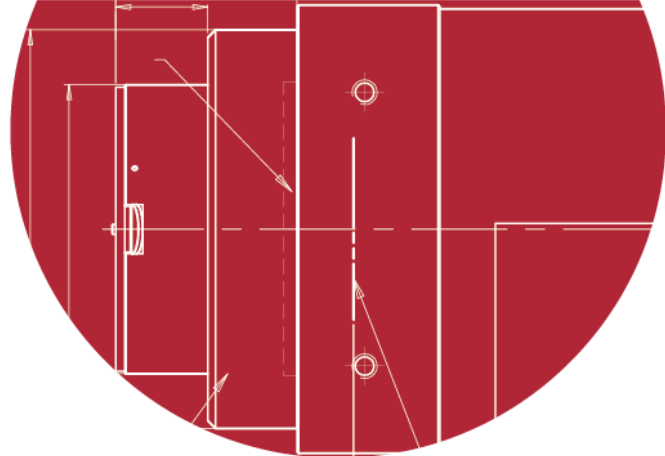

English

VP-71MC-M/C 4

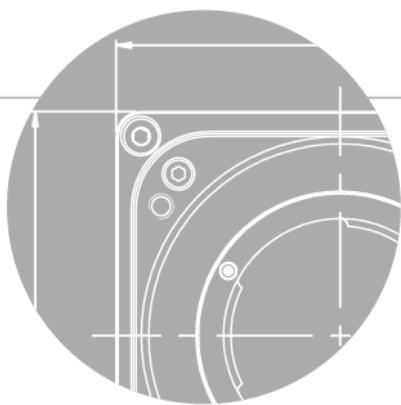

**VIEWWORKS**  
Imaging Expert

**Revision History**

Revision	Date	Description
1.0	2016-08-05	Initial Release
1.1	2017-03-24	Updated the EMC Directive

# Contents

<b>1</b>	<b>Precautions</b> .....	<b>6</b>
<b>2</b>	<b>Warranty</b> .....	<b>8</b>
<b>3</b>	<b>Compliance &amp; Certifications</b> .....	<b>8</b>
3.1	FCC Declaration .....	8
3.2	CE: DoC.....	8
3.2.1	KCC Statement .....	8
<b>4</b>	<b>Package Components</b> .....	<b>9</b>
<b>5</b>	<b>Product Specifications</b> .....	<b>10</b>
5.1	Overview .....	10
5.2	Specifications.....	11
5.3	Camera Block Diagram.....	12
5.4	Sensor Information.....	13
5.5	Mechanical Specification .....	14
<b>6</b>	<b>Connecting the Camera</b> .....	<b>15</b>
6.1	Mount Plate.....	16
6.2	Precaution to center the imaging sensor .....	16
6.3	Precaution about blurring compared to the center.....	16
6.4	Controlling the Camera.....	16
<b>7</b>	<b>Camera Interface</b> .....	<b>17</b>
7.1	General Description .....	17
7.2	Camera Link Connector.....	17
7.3	Power Input Receptacle.....	21
7.4	Control I/O Receptacle.....	22
7.5	Trigger Input Circuit .....	23
7.6	Strobe Output Circuit .....	24
<b>8</b>	<b>Camera Features</b> .....	<b>25</b>
8.1	Region of Interest (ROI).....	25
8.2	Trigger Mode.....	27
8.2.1	Free-Run Mode .....	28
8.2.2	External Sync Mode .....	30
8.2.3	Overlapping Exposure with Sensor Readout .....	31
8.3	Setting the Exposure Time .....	32
8.4	Rolling Shutter .....	33

---

8.5	Camera Link Output.....	34
8.6	Gain and Offset.....	35
8.7	Defective Pixel Correction.....	36
8.7.1	Correction Method.....	36
8.8	Flat Field Correction.....	37
8.9	Dark Image Correction.....	39
8.9.1	Sequence of Dark Image Correction.....	39
8.10	White Pixel.....	40
8.11	Auto White Balance.....	41
8.12	Temperature Monitor.....	41
8.13	Status LED.....	41
8.14	Data Format.....	42
8.15	Test Image.....	43
8.16	Strobe.....	45
8.16.1	Strobe Type.....	45
8.16.2	Strobe Polarity.....	46
8.17	Field Upgrade.....	46
<b>9</b>	<b>Camera Configuration.....</b>	<b>47</b>
9.1	Setup Command.....	47
9.2	Actual Time Applied for Commands.....	49
9.3	Parameter Storage Space.....	50
9.4	Command List.....	52
<b>10</b>	<b>Configurator GUI.....</b>	<b>55</b>
10.1	Camera Scan.....	55
10.2	Menu.....	56
10.2.1	File.....	56
10.2.2	Start-Up.....	57
10.2.3	Tool.....	58
10.2.4	About.....	59
10.3	Tab.....	60
10.3.1	VIEW Tab.....	60
10.3.2	MODE/EXP Tab.....	61
10.3.3	ANALOG Tab.....	62
10.3.4	FFC Tab.....	63
10.3.5	TEC Tab.....	64

**11 Troubleshooting .....65**

**Appendix A Defective Pixel Map Download .....66**

**Appendix B Field Upgrade .....69**

    B.1 MCU.....69

    B.2 FPGA .....72

# 1 Precautions

## General



- Do not drop, disassemble, repair or alter the device. Doing so may damage the camera electronics and cause an electric shock.
- Do not let children touch the device without supervision.
- Stop using the device and contact the nearest dealer or manufacturer for technical assistance if liquid such as water, drinks or chemicals gets into the device.
- Do not touch the device with wet hands. Doing so may cause an electric shock.
- Make sure that the temperature of the camera does not exceed the temperature range specified in [5.2 Specifications](#). Otherwise the device may be damaged by extreme temperatures.

## Installation and Maintenance



- Do not install in dusty or dirty areas - or near an air conditioner or heater to reduce the risk of damage to the device.
- Avoid installing and operating in an extreme environment where vibration, heat, humidity, dust, strong magnetic fields, explosive/corrosive mists or gases are present.
- Do not apply excessive vibration and shock to the device. This may damage the device.
- Avoid direct exposure to a high intensity light source. This may damage the image sensor.
- Do not install the device under unstable lighting conditions. Severe lighting change will affect the quality of the image produced by the device.
- Do not use solvents or thinners to clean the surface of the device. This can damage the surface finish.

## Power Supply



- Applying incorrect power can damage the camera. If the voltage applied to the camera is greater or less than the camera's nominal voltage, the camera may be damaged or operate erratically. Please refer to [5.2 Specifications](#) for the camera's nominal voltage.
  - ※ Vieworks Co., Ltd. does NOT provide power supplies with the devices.
- Make sure the power is turned off before connecting the power cord to the camera. Otherwise, damage to the camera may result.

## Cleaning the Sensor Surface

Avoid cleaning the surface of the camera's sensor if possible. If you have dust or foreign matter on the sensor surface that will not blow off, use a soft lint free cotton bud dampened with a small quantity of high quality lens cleaner. Because electrostatic discharge (ESD) can damage the sensor, you must use a cloth (e.g. cotton) that will not generate static during cleaning.



### **Avoid dust or foreign matter on the sensor surface.**

The camera is shipped with a protective plastic seal on the camera front. To prevent collecting dust or foreign matter on the camera sensor, make sure that you always put the protective seal in place when there is no lens mounted on the camera. In addition, make sure to always point the camera downward when there is no protective seal on the camera front or no lens mounted.

## Procedures for Cleaning the Sensor

If you have dust or foreign matter on the sensor surface, follow the procedures below to wipe off.

1. Remove a contaminant by using an ionizing air gun.  
If this step does not remove the contaminant, proceed to the next step.
2. Clean the contaminant on the sensor using one drop of lens cleaner on a non-fluffy cotton bud.
3. Wipe the cotton bud gently in only one direction (either left to right or right to left). Avoid wiping back and forth with the same cotton bud in order to ensure that the contaminants are removed and not simply transferred to a new location on the sensor surface.
4. Mount a lens, set the lens at a smaller aperture (e.g. F8), and then acquire images under bright lighting conditions. Check the images on the monitor for dark spots or stripes caused by the contaminant. Repeat the steps above until there is no contaminant present.



If the sensor is damaged due to electrostatic discharge or the sensor surface is scratched during cleaning, the warranty is void.

## 2 Warranty

For information about the warranty, please contact your local dealer or factory representative.

## 3 Compliance & Certifications

### 3.1 FCC Declaration

This equipment has been tested and found to comply with the limits for a Class A digital device, pursuant to part 15 of the FCC Rules. These limits are designed to provide reasonable protection against harmful interference when the equipment is operated in a commercial environment. This equipment generates, uses, and can radiate radio frequency energy and, if not installed and used in accordance with the instruction manual, may cause harmful interference to radio communications. Operation of this equipment in a residential area is likely to cause harmful interference in which case the user will be required to correct the interference at own expenses.

### 3.2 CE: DoC

EMC Directive 2014/30/EU

EN 55032:2012 (Class A), EN 55024:2010

Class A

#### 3.2.1 KCC Statement

Type	Description
Class A (Broadcasting Communication Device for Office Use)	This device obtained EMC registration for office use (Class A), and may be used in places other than home. Sellers and/or users need to take note of this.



## 4 Package Components

### Package Components



VP-71MC <F-mount>



Mount Plate (Optional)



M5 Set Screws for Tilt Adjustment (Provided only with F-mount camera)



- You can adjust the tilt using the M5 set screws, however it is not recommended since it is adjusted as factory default settings.
- If the tilt settings need to be adjusted inevitably, please contact your local dealer or factory representative for technical support.

## 5 Product Specifications

### 5.1 Overview

The VP-71MC, the latest member of the industrial proven VP series, is a new 71 megapixel resolution CMOS camera with Camera Link interface. The VP-71MC uses the latest 71 megapixel CMOS imaging sensor (CHR70M) technology from CMOSIS, and offers a frame rate of 4 fps at full resolution.

This camera uses thermos-electric Peltier (TEC) cooling technology developed for, and used by, many demanding medical market customers. The TEC maintains the operating temperature of the CMOS imaging sensor at up to about 20 degrees below ambient temperature. This camera provides a stable operating condition or the ability to expose for a long period of time to increase camera sensitivity. Featured with the stable operating capability and high resolution, this camera is ideal for demanding applications such as FPD, PCB and semiconductor inspections.

#### Main Features

- High Speed 71 Megapixel CMOS Imaging Sensor
- Thermoelectric Peltier Cooling – about 20 degrees below ambient temperature
- Minimizing the Number of Hot Pixels with TEC (up to 99%)
- Electronic Exposure Time Control (Rolling Shutter)
- Output Pixel Format: 8 / 10 / 12 bit
- Strobe Output
- Camera Link Medium Interface
- Camera Link Output Mode: 2 Tap / 4 Tap Normal / 4 Tap High Speed
- Gain/Offset Control
- Test Image
- LVDS (RS-644) Serial Communication by Camera Link Interface
- Temperature Monitor
- Field Upgrade
- Flat Field Correction
- Defect Pixel Correction
- Dark Image Correction
- Non-uniformity Correction (DSNU and PRNU)

## 5.2 Specifications

The technical specifications of the VP-71MC are as follows.

Specifications	VP-71MC-4
Resolution (H x V)	10000 × 7096
Sensor	CMOSIS CHR70M
Sensor Size (mm <sup>2</sup> )	31.00 × 22.00 (Diagonal: 38 mm)
Sensor Type	High Speed Progressive Scan CMOS Imaging Sensor
Pixel size	3.1 μm × 3.1 μm
Interface	Camera Link
Electronic Shutter	Rolling Shutter
Max. Frame Rate	2 Tap: 2.1 fps
	4 Tap Normal Speed: 2.9 fps
	4 Tap High Speed: 4.2 fps
Transfer Time	2 Tap: 476 ms
	4 Tap Normal Speed: 335 ms
	4 Tap High Speed: 238 ms
Pixel Data Format	8 bit / 10 bit / 12 bit
Camera Link Pixel Clock	60 MHz / 85 MHz
Exposure Time	66 μs ~ 7 sec (1 line step)
Black Offset	0 ~ 63 LSB, 64 step
Video Gain	0 ~ 12 dB, 64 step
Trigger Mode	Free-Run, Trigger Programmable Exposure Time and Trigger Polarity
External Trigger	External, 3.3 V ~ 24.0 V Logical level input, Optically isolated
Software Trigger	Camera Link CC1
Dynamic Range	63 dB
Lens Mount	F-mount
Cooling Method	Thermoelectric Peltier Cooling
Cooling Performance	About 20°C below ambient temperature / Standard cooling with a fan
Power	10 ~ 24 V DC, Typ. 20.0 W / Max. 24.0 W
Environmental	Operating: 0°C ~ 40°C, Storage: -40°C ~ 70°C
Mechanical	90 mm × 90 mm × 137 mm, 1500 g (with F-mount)
Configuration SW	Configurator

**Table 5.1 Specifications of VP-71MC**

## 5.3 Camera Block Diagram

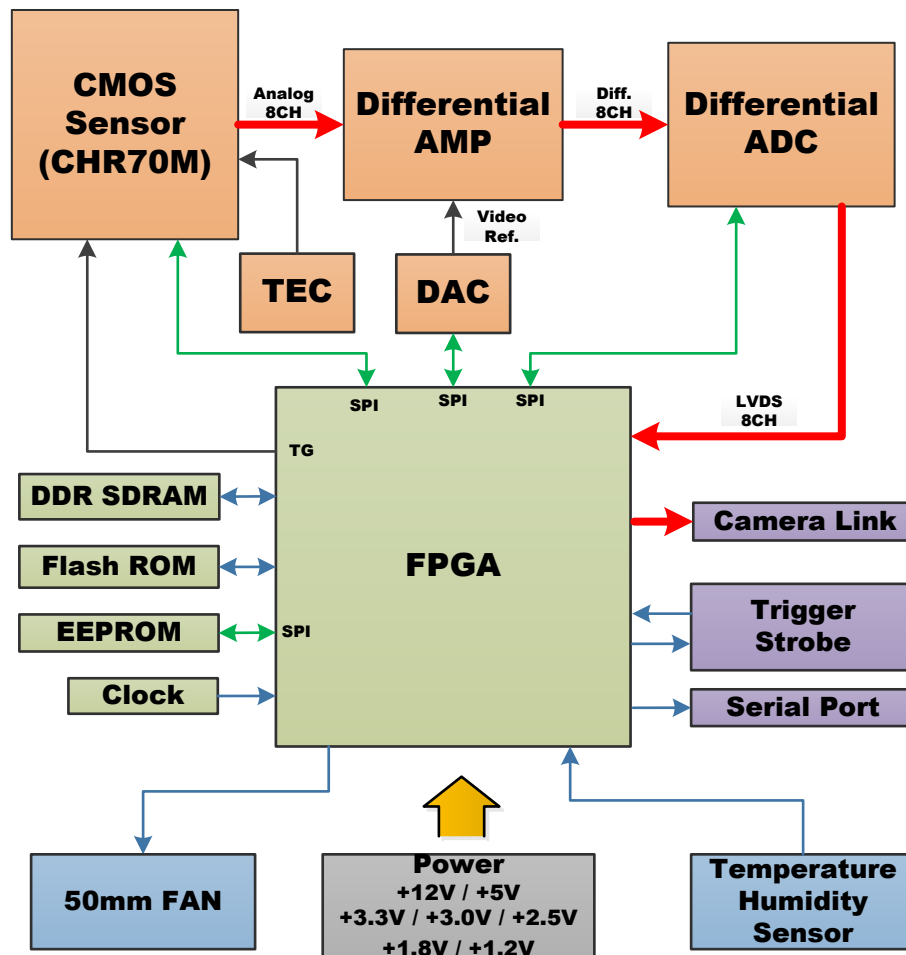
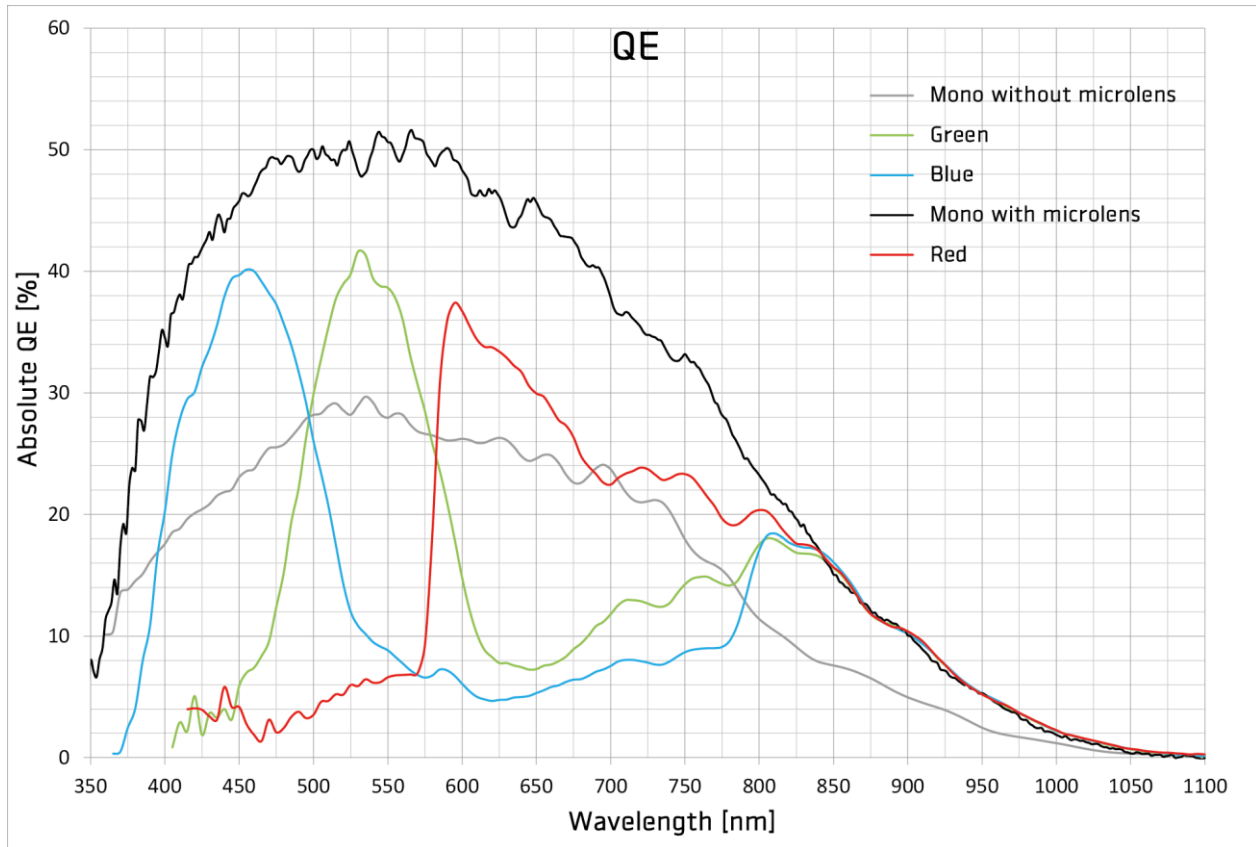

Figure 5.1 Camera Block Diagram

All controls and data processing of VP-71MC camera are carried out in one FPGA chip. The FPGA generally consists of a 32 bit RISC Micro-Controller and Processing & Control logic. The Micro-Controller receives commands from the user through the Camera Link interface and then processes them. The Processing & Control logic processes the image data received from the CMOS imaging sensor and then transmits data through the Camera Link interface. The Processing & Control logic also controls the trigger inputs and strobe outputs which are sensitive to time. Furthermore, FLASH and DDR2 are installed outside FPGA. DDR2 is used to process image data and FLASH stores the firmware to operate the Micro-Controller. And a Peltier Driver is applied to control a Thermoelectric Peltier Cooling unit.

## 5.4 Sensor Information

The following graphs show the quantum efficiency of the VP-71MC monochrome and color cameras.



**Figure 5.2 Mono and Color Quantum Efficiency for VP-71MC**

## 5.5 Mechanical Specification

The camera dimensions in millimeters are as shown in the following figure.

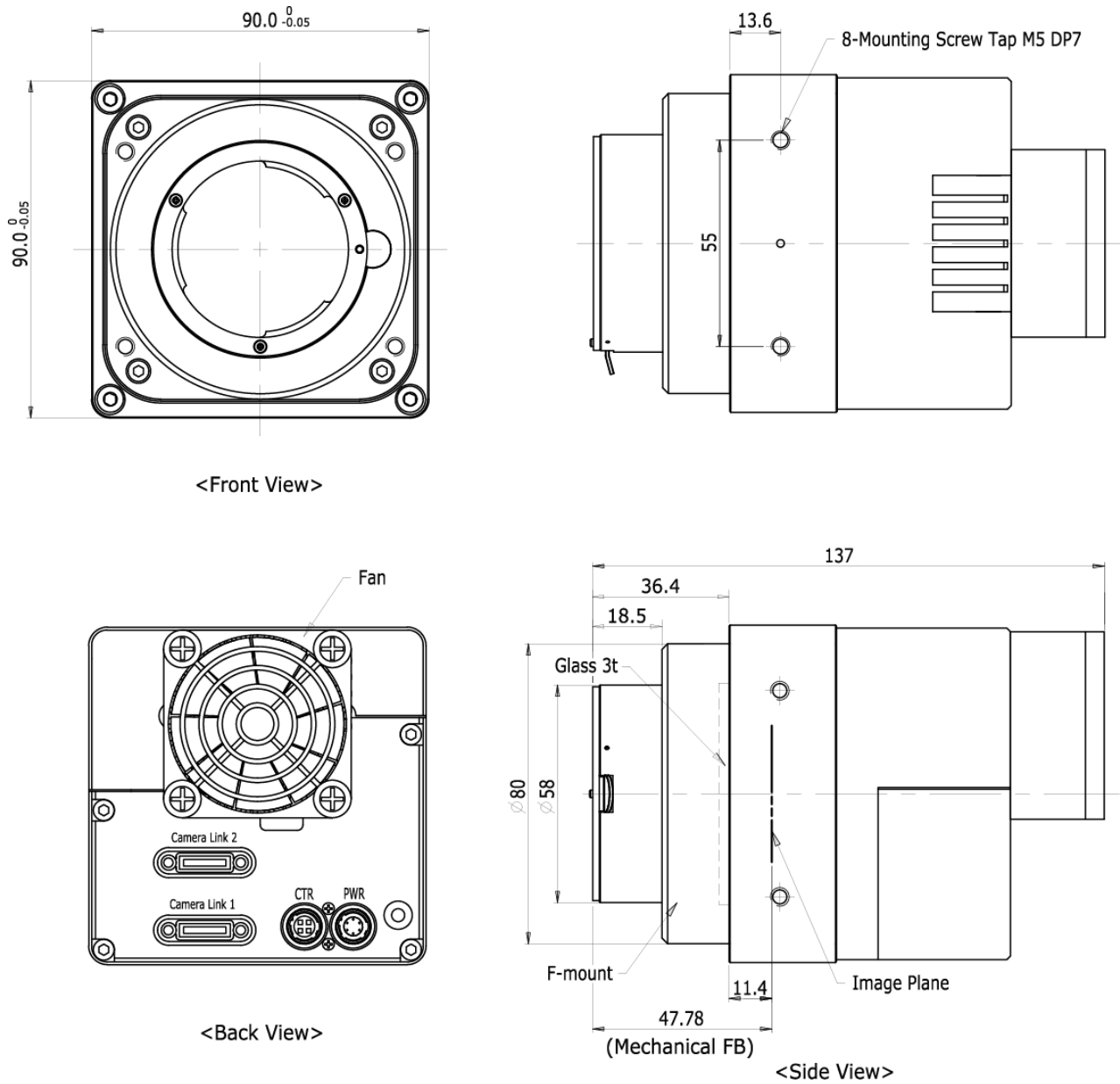

Figure 5.3 VP-71MC Camera Link F-mount Mechanical Dimension

## 6 Connecting the Camera

The following instructions assume that you have installed a Camera Link frame grabber in your computer including related software. For more information, refer to your Camera Link frame grabber user manual.

To connect the camera to your computer, follow the steps below:

1. Make sure that the power supply is not connected to the camera and your computer is turned off.
2. Plug one end of a Camera Link cable into the Camera Link1 connector on the camera and the other end of the Camera Link cable into the Base connector on the Camera Link frame grabber.
3. Plug one end of a Camera Link cable into the Camera Link2 connector on the camera and the other end of the Camera Link cable into the Medium/Full connector on the Camera Link frame grabber.
4. Connect the plug of the power adaptor to the power input receptacle on the camera.
5. Plug the power adaptor into a working electrical outlet.
6. Verify all the cable connections are secure.

### Precautions for using Camera Link Medium Configuration



VP-71MC camera supports Camera Link Base and Medium configurations. To operate the camera in the medium configuration, you must connect the camera to the Camera Link frame grabber using two Camera Link cables. At this time, you must connect both Camera Link1 (Base) and Camera Link2 (Medium/Full) connectors on the camera to their respective connectors on the Camera Link frame grabbers.

## 6.1 Mount Plate

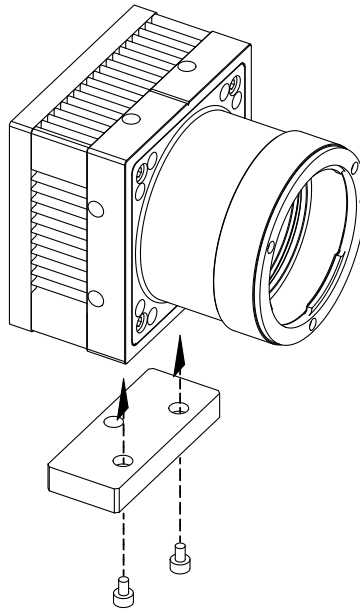

- The mount plate is provided as an optional item.
- The camera can be installed without using this mount plate.

## 6.2 Precaution to center the imaging sensor

- User does not need to center the imaging sensor as it is adjusted as factory default settings.
- When you need to adjust the center of imaging sensor, please contact your local dealer or factory representative for technical assistance.

## 6.3 Precaution about blurring compared to the center

- User does not need to adjust the tilt as it is adjusted as factory default settings.
- If the tilt settings need to be adjusted inevitably, please contact your local dealer or factory representative for technical support.

## 6.4 Controlling the Camera

- You can control the camera by using Configurator.
- You can download the latest Configurator at <http://www.vieworks.com>.
- Please refer to your Camera Link frame grabber user manual.



## 7 Camera Interface

### 7.1 General Description

As shown in the following figure, four types of connectors and a status indicator LED are located on the back of the camera and have the functions as follows:

- ① 26 pin Camera Link Connector 2 (Medium): transmits video data.
- ② 26 pin Camera Link Connector 2 (Base): controls video data transmission and the camera.
- ③ Status LED: displays power status and operation mode.
- ④ 6 pin power Input Receptacle: supplies power to the camera.
- ⑤ 4 pin Control I/O Receptacle: inputs external trigger signal and outputs strobe signal.

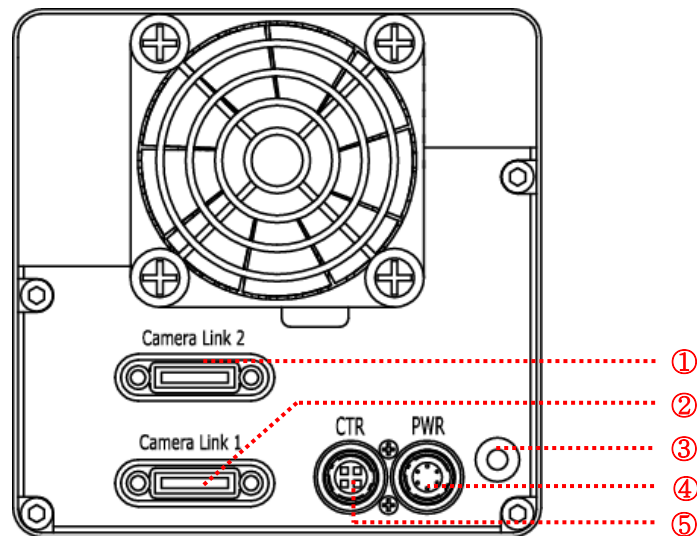

Figure 7.1 VP-71MC Camera Back Panel

### 7.2 Camera Link Connector

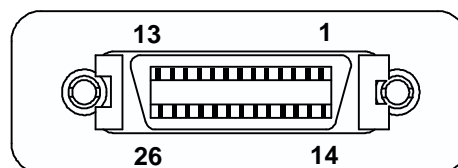

Figure 7.2 Camera Link Connector

Camera Link connectors comply with Camera Link Standard and the following list shows the pin assignments of the connector.

PAIR List	Pin	Signal Name	Type	Description
PAIR 0	1	Ground	Ground	Cable Shield
	14	Ground	Ground	Cable Shield
PAIR 1	2	-X0	LVDS - Out	Camera Link Transmitter
	15	+X0	LVDS - Out	Camera Link Transmitter
PAIR 2	3	-X1	LVDS - Out	Camera Link Transmitter
	16	+X1	LVDS - Out	Camera Link Transmitter
PAIR 3	4	-X2	LVDS - Out	Camera Link Transmitter
	17	+X2	LVDS - Out	Camera Link Transmitter
PAIR 4	5	-XCLK	LVDS - Out	Camera Link Transmitter
	18	-XCLK	LVDS - Out	Camera Link Transmitter
PAIR 5	6	-X3	LVDS - Out	Camera Link Transmitter
	19	+X3	LVDS - Out	Camera Link Transmitter
PAIR 6	7	+ SerTC	LVDS - In	Serial Data Receiver
	20	- SerTC	LVDS - In	Serial Data Receiver
PAIR 7	8	- SerTFG	LVDS - Out	Serial Data Transmitter
	21	+ SerTFG	LVDS - Out	Serial Data Transmitter
PAIR 8	9	- CC 1	LVDS - In	Software External Trigger
	22	+ CC 1	LVDS - In	Software External Trigger
PAIR 9	10	N/C	N/C	N/C
	23	N/C	N/C	N/C
PAIR 10	11	N/C	N/C	N/C
	24	N/C	N/C	N/C
PAIR 11	12	N/C	N/C	N/C
	25	N/C	N/C	N/C
PAIR 12	13	Ground	Ground	Cable Shield
	26	Ground	Ground	Cable Shield

**Table 7.1 Pin Assignments for Camera Link Connector 1**

PAIR List	Pin	Signal Name	Type	Description
PAIR 0	1	Ground	Ground	Cable Shield
	14	Ground	Ground	Cable Shield
PAIR 1	2	-Y0	LVDS - Out	Camera Link Transmitter
	15	+Y0	LVDS - Out	Camera Link Transmitter
PAIR 2	3	-Y1	LVDS - Out	Camera Link Transmitter
	16	+Y1	LVDS - Out	Camera Link Transmitter
PAIR 3	4	-Y2	LVDS - Out	Camera Link Transmitter
	17	+Y2	LVDS - Out	Camera Link Transmitter
PAIR 4	5	-YCLK	LVDS - Out	Camera Link Transmitter
	18	+YCLK	LVDS - Out	Camera Link Clock Tx
PAIR 5	6	-Y3	LVDS - Out	Camera Link Channel Tx
	19	+Y3	LVDS - Out	Camera Link Channel Tx
PAIR 6	7	-	Not Used	Connected with 100 ohm
	20	-	Not Used	
PAIR 7	8	-Z0	LVDS - Out	Camera Link Transmitter
	21	+Z0	LVDS - Out	Camera Link Transmitter
PAIR 8	9	-Z1	LVDS - Out	Camera Link Transmitter
	22	+Z1	LVDS - Out	Camera Link Transmitter
PAIR 9	10	-Z2	LVDS - Out	Camera Link Transmitter
	23	+Z2	LVDS - Out	Camera Link Transmitter
PAIR 10	11	-ZCLK	LVDS - Out	Camera Link Transmitter
	24	+ZCLK	LVDS - Out	Camera Link Clock Tx
PAIR 11	12	-Z3	LVDS - Out	Camera Link Channel Tx
	25	+Z3	LVDS - Out	Camera Link Channel Tx
PAIR 12	13	Ground	Ground	Cable Shield
	26	Ground	Ground	Cable Shield

Table 7.2 Pin Assignments for Camera Link Connector 2

Model	Camera Link Output Mode	CL Configuration	CL Connector 1	CL Connector 2
VP-71MC-4	2 Tap	BASE	O	X
	4 Tap Normal	MEDIUM	O	O
	4 Tap High	MEDIUM	O	O

**Table 7.3 Connector Arrangement for the Camera Link Output Modes**



When you connect a Frame Grabber to Camera Link Connectors on the camera using Camera Link cables, make sure you connect to the correct Camera Link Connector. Incorrect connection of Connector 1 and Connector 2 may cause malfunction of the camera or communication problems between your computer and the camera.

## 7.3 Power Input Receptacle

The power input receptacle is a Hirose 6 pin connector (part # HR10A-7R-6PB). The pin assignments and configurations are as follows:

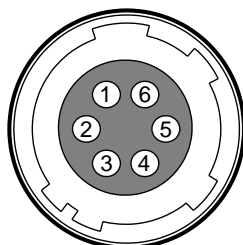

**Figure 7.3 Pin Assignments for Power Input Receptacle**

Pin Number	Signal	Type	Description
1, 2, 3	+ 12V DC	Input	DC Power Input
4, 5, 6	DC Ground	Input	DC Ground

**Table 7.4 Pin Configurations for Power Input Receptacle**

The mating connector is a Hirose 6 pin plug (part # HR10A-7P-6S) or the equivalent connectors. The power adapter is recommended to have at least 1 A current output at 12 V DC  $\pm 10\%$  voltage output (Users need to purchase the power adapter separately).

### Precaution for Power Input



- Make sure the power is turned off before connecting the power cord to the camera. Otherwise, damage to the camera may result.
- If the voltage applied to the camera is greater than specified in the specifications, damage to the camera may result.

## 7.4 Control I/O Receptacle

The Control I/O Receptacle is a Hirose 4 pin connector (part # HR10A-7R-4S) and consists of an external trigger signal input and strobe output port. The pin assignments and configurations are as follows:

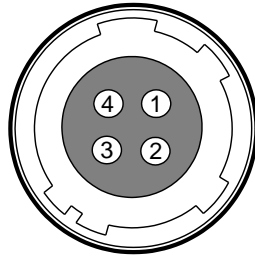

**Figure 7.4 Pin Assignments for Control I/O Receptacle**

Pin Number	Signal	Type	Description
1	Trigger Input +	Input	-
2	Trigger Input -	Input	-
3	DC Ground	-	DC Ground
4	Strobe Out	Output	3.3 V TTL Output Output resistance: 47 $\Omega$

**Table 7.5 Pin Configurations for Control I/O Receptacle**

The mating connector is a Hirose 4 pin plug (part # HR10A-7P-4P) or the equivalent connectors.

## 7.5 Trigger Input Circuit

The following figure shows trigger signal input circuit of the 4 pin connector. Transmitted trigger signal is applied to the internal circuit through a photo coupler. The minimum trigger width that can be recognized by the camera is 1  $\mu$ s. If transmitted trigger signal is less than 1  $\mu$ s, the camera will ignore the trigger signal. An external trigger circuit example is shown below.

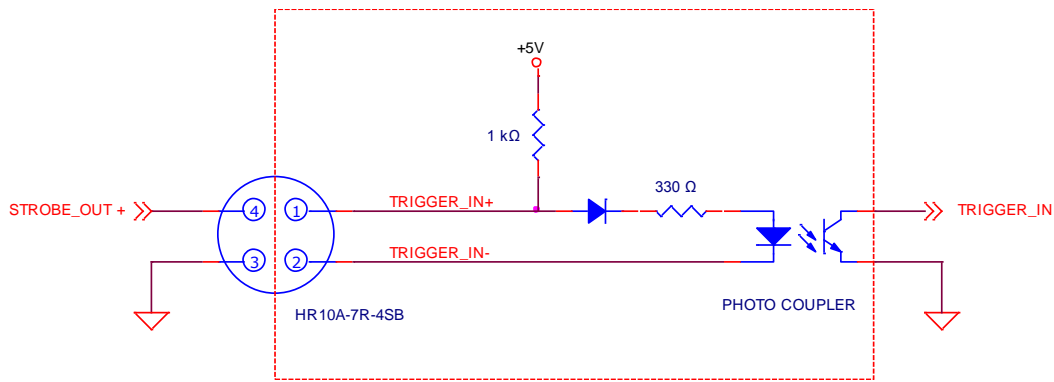

Figure 7.5 Trigger Input Schematic

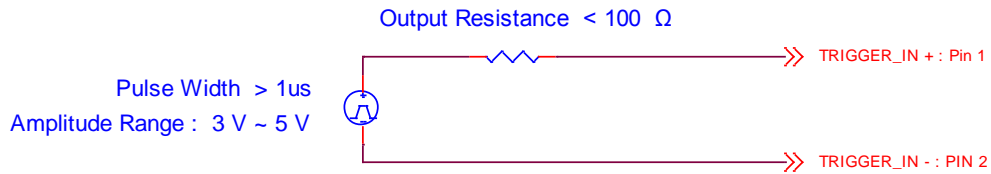

Figure 7.6 Recommended Pulse Trigger Driver Input

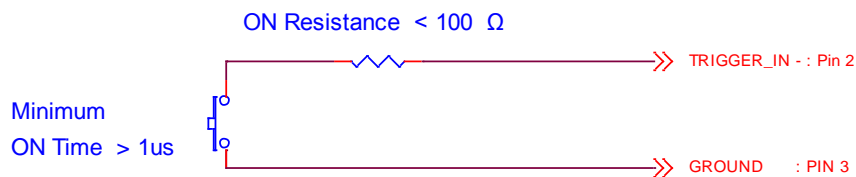
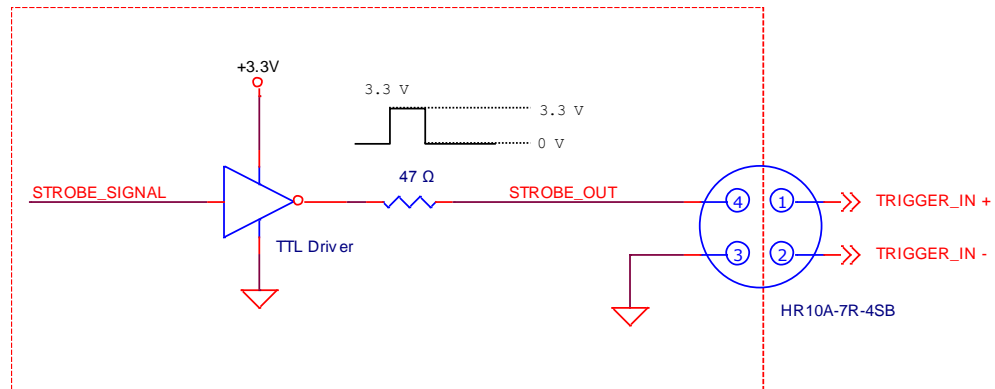

Figure 7.7 Recommended Contact Trigger Input

## 7.6 Strobe Output Circuit

The strobe output signal comes out through a 3.3 V output level of TTL Driver IC. A pulse width of signal is synchronized with an exposure (shutter) signal of the camera.



**Figure 7.8 Strobe Output Schematic**



## 8 Camera Features

### 8.1 Region of Interest (ROI)

The Region of Interest (ROI) feature allows you to specify a portion of the sensor array. You can acquire only the frame data from the specified portion of the sensor array while preserving the same quality as you acquire a frame from the entire sensor array.

On the VP-71MC camera, decreasing the Height and Width of the ROI can increase the camera’s maximum allowed frame rate. The ROI is referenced to the top left corner [origin (0, 0)] of the sensor array as shown below.

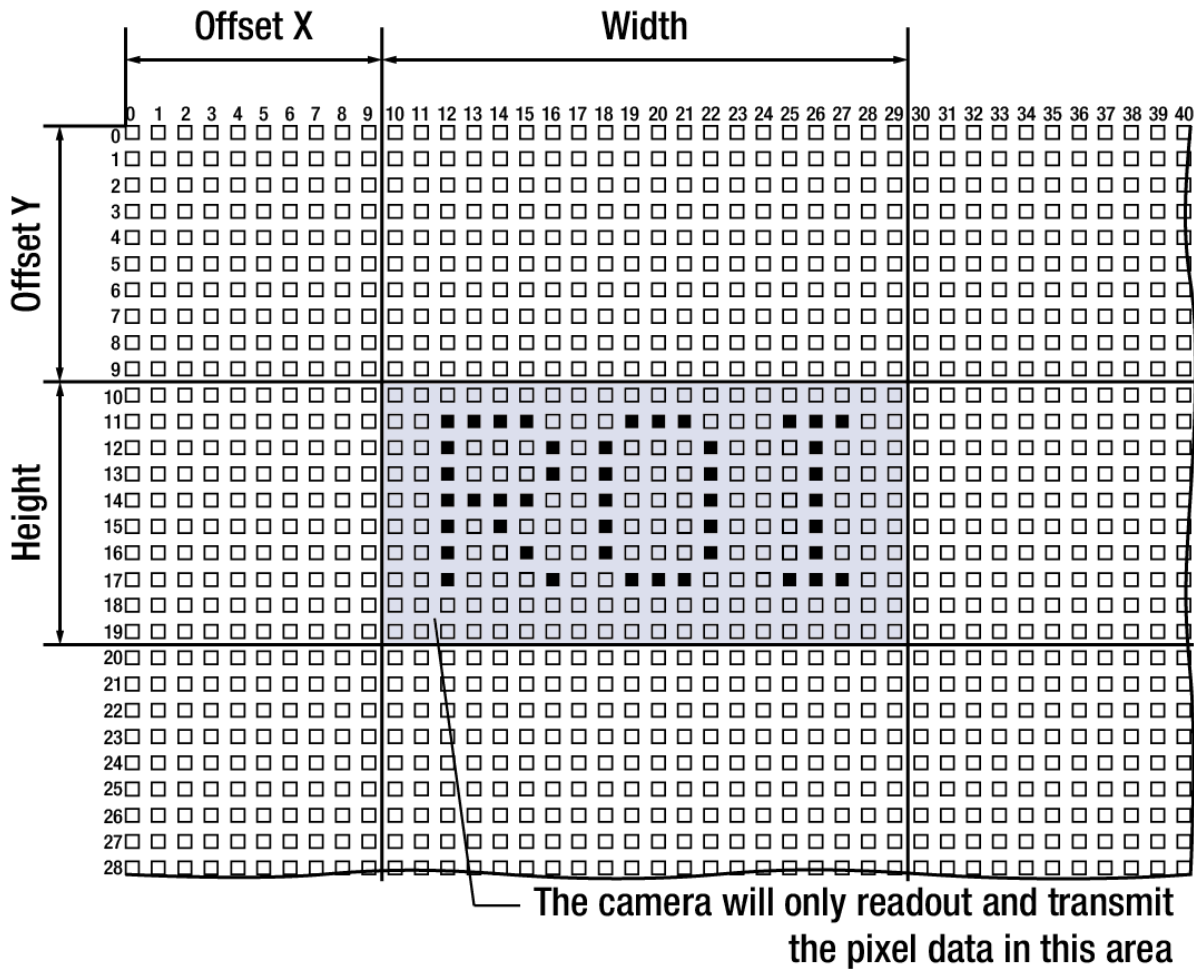

Figure 8.1 Region of Interest

On the VP-71MC camera, the Height must be set to a multiple of 8, and the Width must be set to a multiple of 16. The maximum allowed frame rate depending on Horizontal ROI and Vertical ROI changes are shown below.

ROI Size (H × V)	2 Tap	4 Tap Normal	4 Tap High
1000 × 7096	10.2 fps	14.4 fps	20.4 fps
2000 × 7096	7.1 fps	10.1 fps	14.3 fps
4000 × 7096	4.4 fps	6.3 fps	8.9 fps
6000 × 7096	3.2 fps	4.6 fps	6.5 fps
8000 × 7096	2.5 fps	3.6 fps	5.1 fps
10000 × 7096	2.1 fps	2.9 fps	4.2 fps

**Table 8.1 VP-71MC Maximum Frame Rate depending on Horizontal ROI Values**

ROI Size (H × V)	2 Tap	4 Tap Normal	4 Tap High
10000 × 1000	14.9 fps	21.1 fps	29.9 fps
10000 × 2000	7.4 fps	10.5 fps	14.9 fps
10000 × 4000	3.7 fps	5.2 fps	7.4 fps
10000 × 6000	2.4 fps	3.5 fps	4.9 fps
10000 × 7096	2.1 fps	2.9 fps	4.2 fps

**Table 8.2 VP-71MC Maximum Frame Rate depending on Vertical ROI Values**



Your Frame Grabber may place additional restrictions on how the ROI location and size must be set. Refer to your frame grabber user manual for more information.

## 8.2 Trigger Mode

When the **Trigger Mode** is set to **Free-Run**, the camera will generate all required trigger signals internally, and you do not need to apply trigger signal to the camera.

When the **Trigger Mode** is set to **External Sync**, you must apply a trigger signal to the camera each time you want to begin a frame acquisition. The **Source** parameter specifies the source signal that will act as the trigger signal. The available settings for the **Source** parameter are:

- **CC1 port:** You can apply a trigger signal to the camera via Camera Link CC1 port.  
For more information, refer to your Camera Link frame grabber user manual.
- **External port:** You can apply a trigger signal to the camera by injecting an externally generated electrical signal (commonly referred to as a hardware trigger signal) into the Control I/O receptacle on the camera.

If the **Source** parameter is set to CC1 port or External port, you must also set the **Polarity** parameter.

The available settings for the Polarity parameter are:

- **Active Low:** Specifies that a falling edge of the electrical signal will act as the trigger signal.
- **Active High:** Specifies that a rising edge of the electrical signal will act as the trigger signal.

## 8.2.1 Free-Run Mode

When the **Trigger Mode** is set to **Free-Run**, the camera will generate all required trigger signals internally. When the camera is set this way, the exposure time for each frame acquisition is determined by the value of the camera's **Exposure Time** parameter. The camera will constantly acquire images (repeat exposure and readout) without any need for triggering by the user.

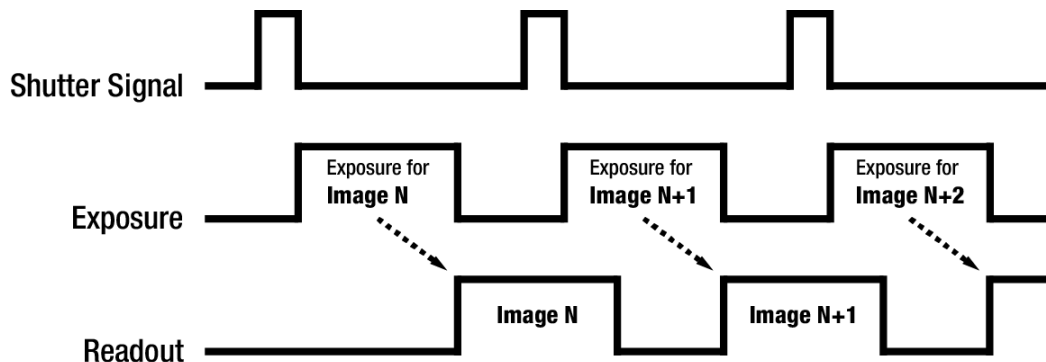
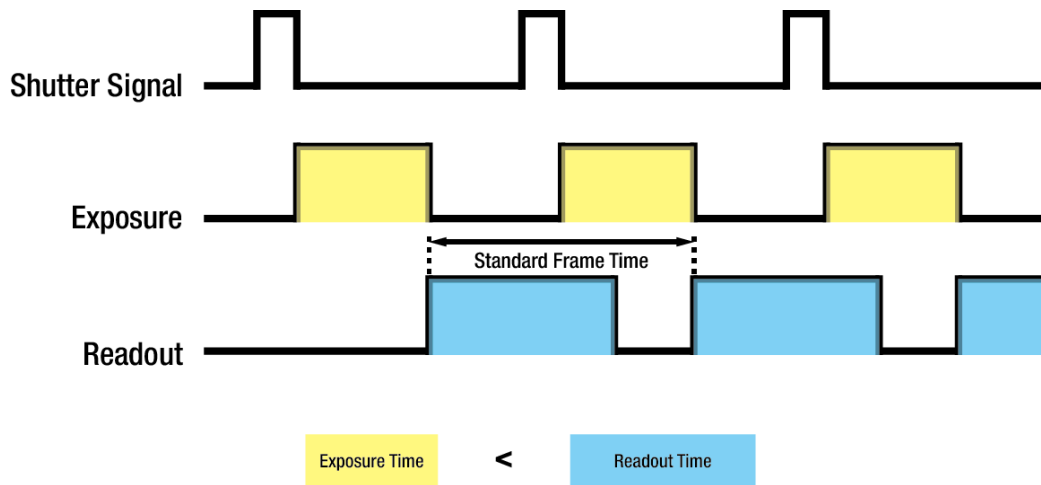

Figure 8.2 Free-Run Mode

With the Trigger Mode set to Free-Run, the exposure for a new frame will overlap the readout for the previous frame. The operation of the camera may differ depending on the length of the exposure time and readout time.

If the exposure time is shorter than the readout time, a shutter signal will be generated while reading out the sensor data for the previously acquired frame. Then, the camera will begin reading out the sensor data for a new frame as soon as it finishes reading out the sensor data for the previous frame. In this case, the frame speed will be constant regardless of changes in the exposure time.



**Figure 8.3 Exposure Time is shorter than Readout Time**

If the exposure time is longer than the readout time, the camera will begin the process of reading out a frame each time a shutter signal is generated. After completing the process of reading out the frame, the camera will not begin the process of reading out a new frame until the camera completes the process of exposing a new frame. In this case, the frame speed becomes slower as you increase the exposure time value.

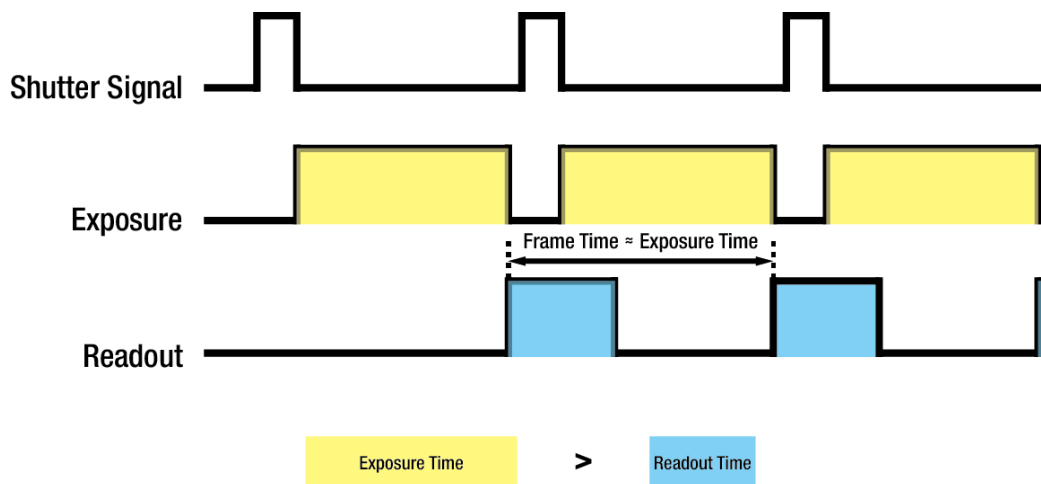

**Figure 8.4 Exposure Time is longer than Readout Time**

## 8.2.2 External Sync Mode

When the **Trigger Mode** is set to **External Sync**, you must trigger exposure start by applying trigger signals to the camera. Applying a trigger signal to the camera will exit the camera from the waiting for trigger signal acquisition status and will begin the process of exposing and reading out a frame. After the readout for the frame is complete and the camera is ready to accept another trigger signal, it will return to the waiting for trigger signal acquisition status. Trigger signals applied to the camera when it is not in a waiting for trigger signal acquisition status will be ignored.

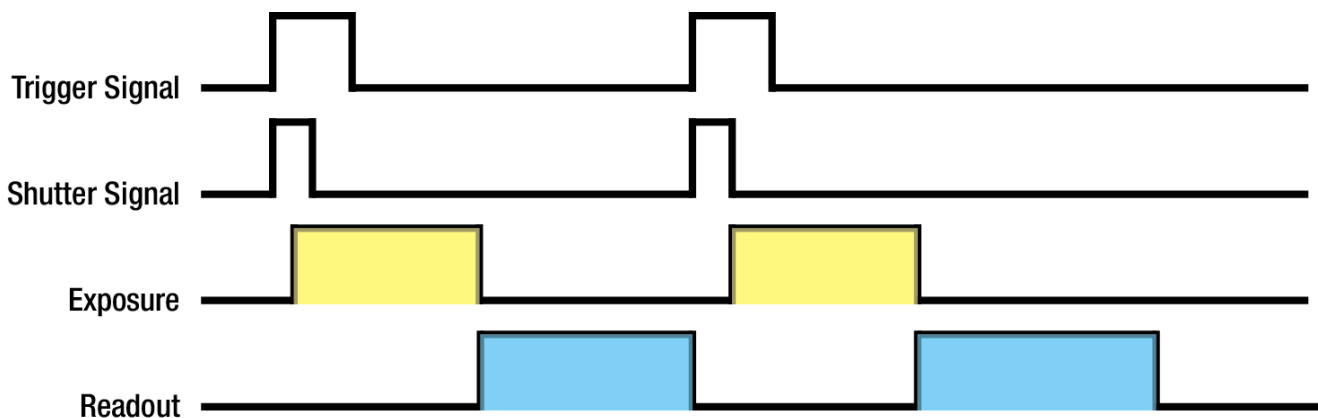

Figure 8.5 External Sync Mode

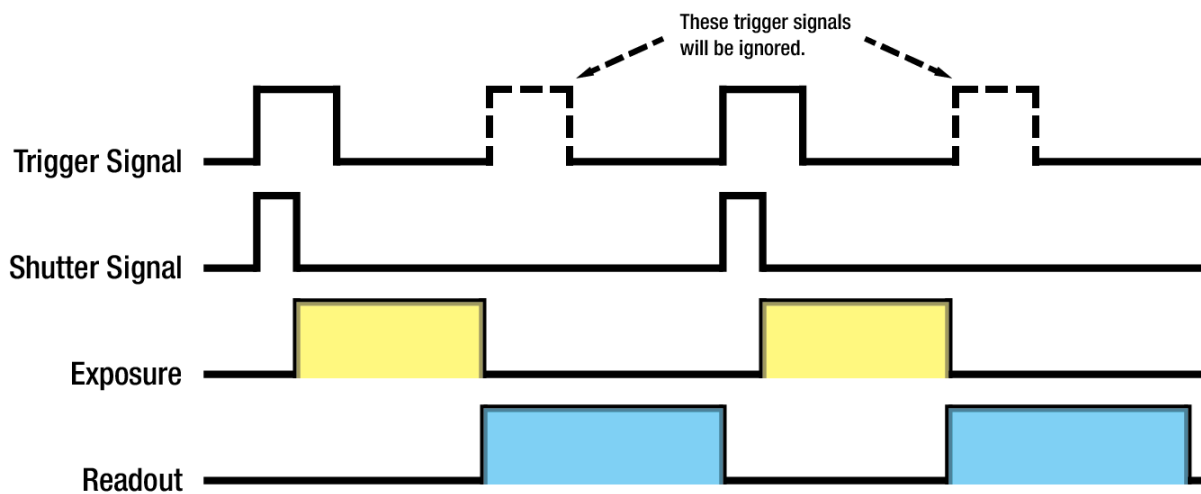

Figure 8.6 Trigger Ignored

### 8.2.3 Overlapping Exposure with Sensor Readout

The frame acquisition process on the camera includes two distinct parts. The first part is the exposure of the pixels in the imaging sensor. Once exposure is complete, the second part of the process – readout of the pixel values from the sensor – takes place. In regard to this frame acquisition process, VP-71MC camera basically operates with ‘overlapped’ exposure so that the exposure for a new frame can be overlapped with the sensor readout for the previous frame.

When a new trigger signal is applied to the camera while reading out the previous frame, the camera begins the process of exposing a new frame. This situation is illustrated in the following figure with the **Trigger Mode** set to **External Sync**, the **Exposure** set to **Pulse Width** and the **Source** set to **External port**.

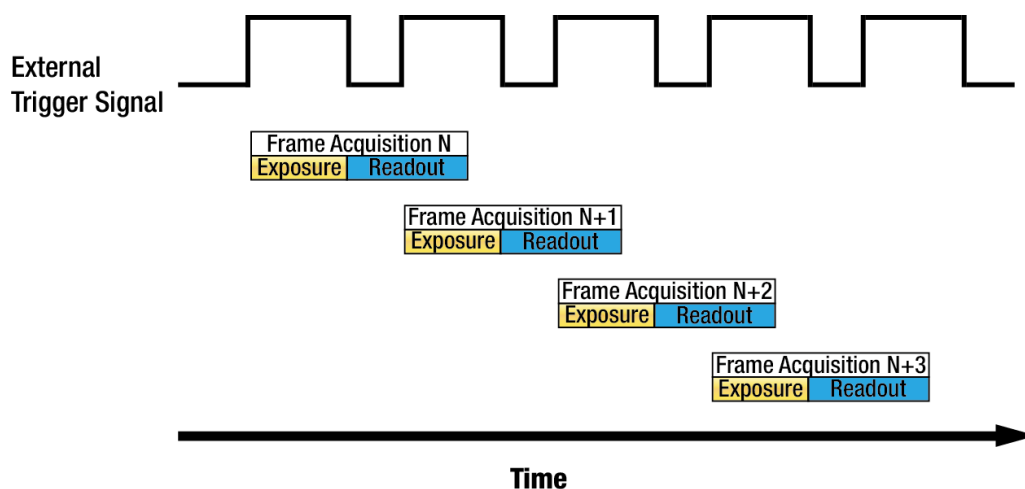

Figure 8.7 Overlapped Exposure and Readout

Determining whether your camera is operating with overlapped exposure and readout is not a matter of changing a setting. Rather a way that you operate the camera will determine whether the exposures and readouts are overlapped or not. If we define the ‘Frame Period’ as the time from the start of exposure for one frame acquisition to the start of exposure for the next frame acquisition, then:

- Overlapped Operation:  $\text{Frame Period} \leq \text{Exposure Time} + \text{Readout Time}$

#### Guidelines for Overlapped Exposure

If you are operating the camera in a way that exposure and readout will be overlapped, there are two important guidelines to keep in mind:

- You must not begin the exposure for a new frame while the exposure for the previous frame is in progress.
- You must not end the exposure for the current frame until the readout for the previous frame is complete.

When you are operating the camera with overlapped exposure and using an external trigger signal to trigger image acquisition, you could use the camera’s Exposure Time parameter settings and timing formula to calculate when it is safe to begin each new acquisition.

## 8.3 Setting the Exposure Time

This section describes how the exposure time can be adjusted manually by setting the **Exposure Time** ('set' command) parameter. If you are operating the camera in any one of the following ways, you must specify an exposure time by setting the camera's **Exposure Time** parameter.

- the **Trigger Mode** is set to **Free-Run**
- the **Trigger Mode** is set to **External Sync** and the **Exposure** is set to **Program**

When you set the Exposure Time below to a minimum specified value, it will be set to the minimum specified value automatically. The Exposure Time parameter sets the exposure time in microseconds ( $\mu s$ ). The minimum and maximum allowed exposure time settings for the camera are shown in the following table.

Camera Model	Camera Link Output	Minimum Exposure Time	Maximum Exposure Time <sup>†</sup>
VP-71MC	2 Tap	132 $\mu s$ (2 line time)	7,000,000 $\mu s$
	4 Tap Normal	94 $\mu s$ (2 line time)	7,000,000 $\mu s$
	4 Tap High	66 $\mu s$ (2 line time)	7,000,000 $\mu s$

†: When the **Exposure** is set to **Pulse Width**, the exposure time is controlled by the external trigger signal and has no maximum limit.

**Table 8.3 Minimum and Maximum Exposure Time Setting**



## 8.4 Rolling Shutter

The VP-71MC camera is equipped with an electronic rolling shutter. The camera exposes and reads out the pixel line with a temporal offset ( $t_{Row}$ ) from one line to the next. When a trigger signal is applied to the camera, the camera resets the top line of pixels (Line 1) and begins exposing that line. The camera resets line two  $t_{Row}$  later and begins exposing the line. And so on until the bottom line of pixels (Line N) is reached. The pixel values for each line are read out at the end of exposure for the line. The readout time for each line is identical to the  $t_{Row}$  value.

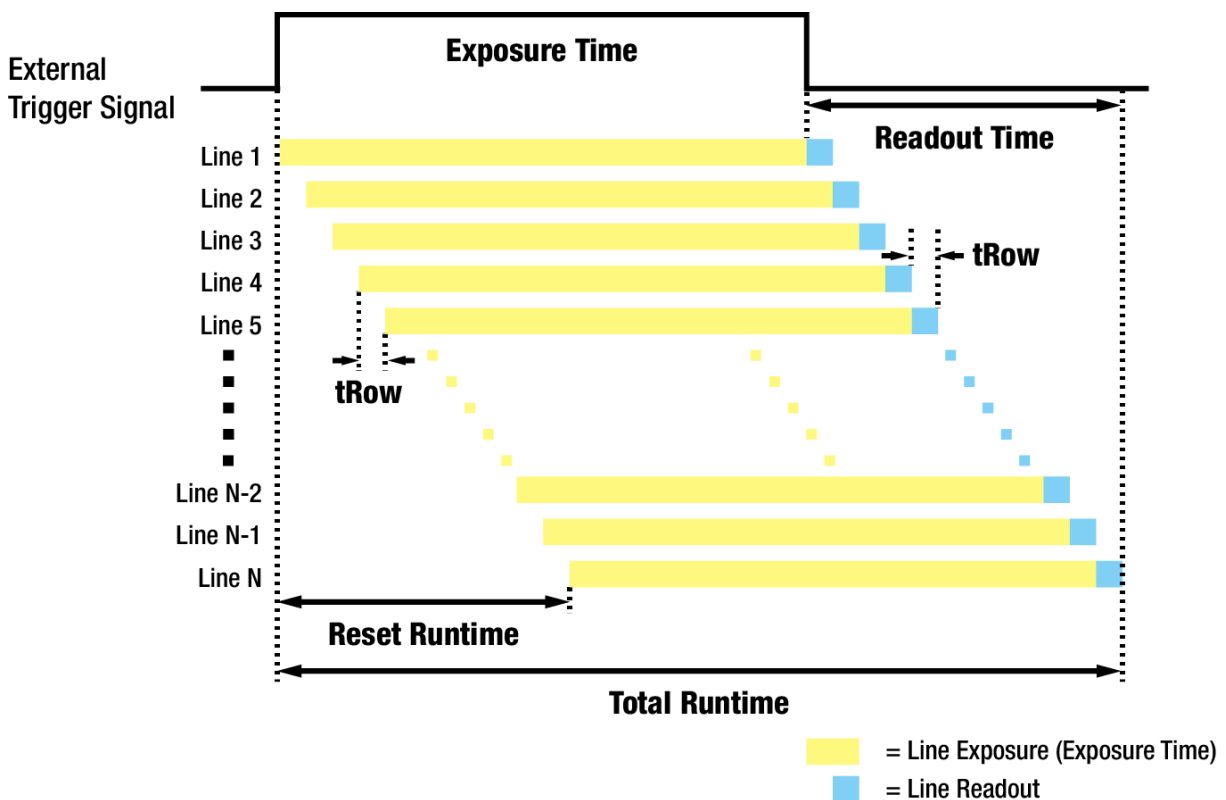

Figure 8.8 Rolling Shutter Operation

The  $t_{Row}$  values depending on the camera's Camera Link Output modes are as follows:

Camera Link Output	Camera Link Pixel Clock	$t_{Row}$
2 Tap	85 MHz	66.7 $\mu s$
4 Tap – Normal Speed	60 MHz	47.2 $\mu s$
4 Tap – High Speed	85 MHz	33.3 $\mu s$

Table 8.4 Temporal Offset Values depending on the Camera Link Output Modes

## 8.5 Camera Link Output

The VP-71MC supports 2 Tap, 4 Tap (Normal Speed) and 4 Tap (High Speed) Camera Link Output modes. The number of taps represents the number of pixel data that will be output on each cycle of the Camera Link Pixel Clock. The image data is transmitted in the interleaved order as shown in the figure below. You can set the Camera Link Output parameter by using the 'scl' command.

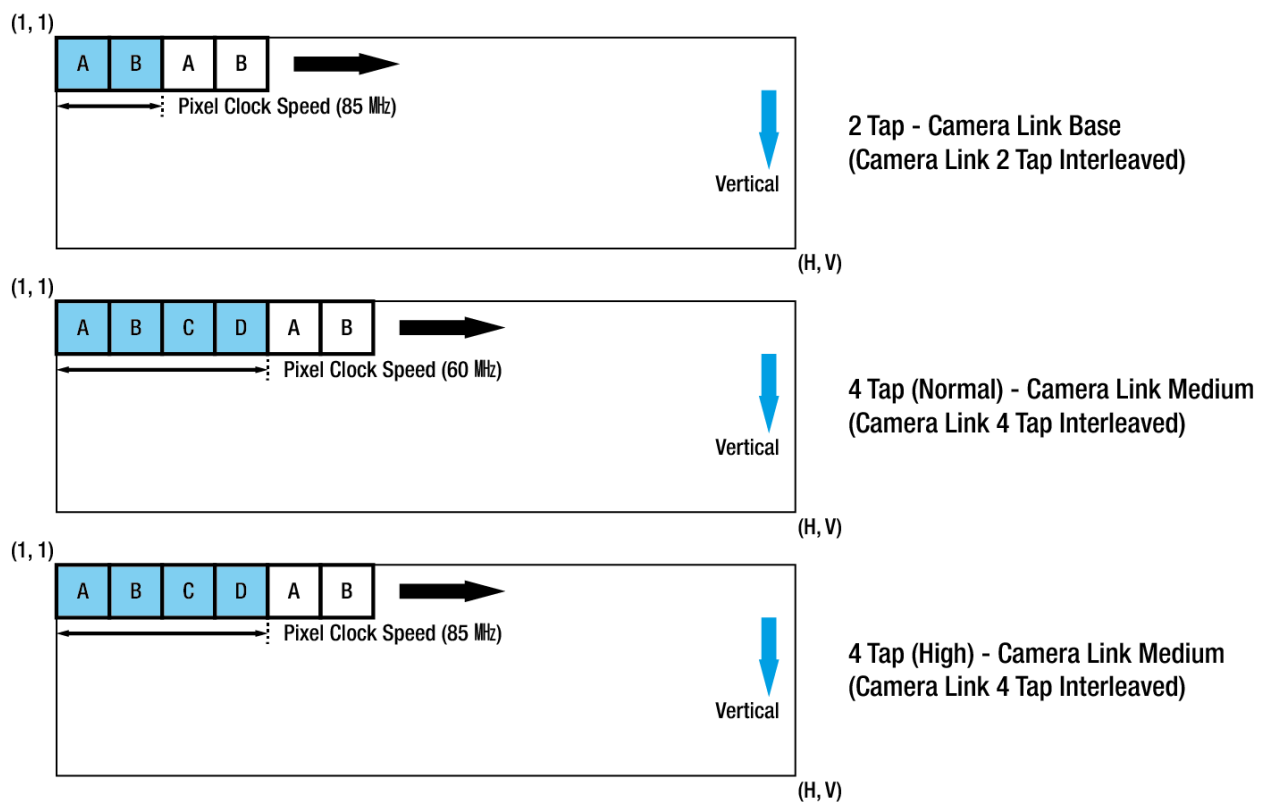

Figure 8.9 Camera Link Output Mode

## 8.6 Gain and Offset

Increasing the **Gain** setting value increases the slope of the camera's response curve as shown in the figure below. This results in a higher grey value output from the camera for a given amount of output from the imaging sensor. The Gain can be set in a range from 0 to 12 dB with 64 steps. If you know the current setting value for the Gain, you can use the formula below to calculate the actual Gain in dB.

$$\text{Gain(dB)} = (\text{setting value}) \times 0.19 \text{ dB}$$

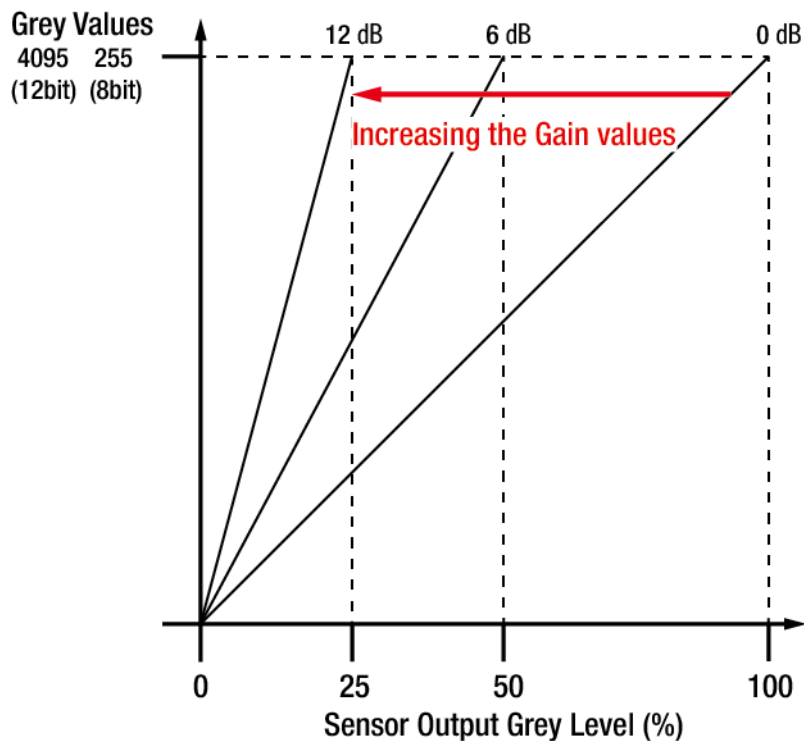

Figure 8.10 Setting the Gain

Adjusting the **Offset** setting value will result in an offset to the pixel values output from the camera. The Offset can be set in a range from 0 to 63 (LSB) with 64 steps based on 12 bit data format.

## 8.7 Defective Pixel Correction

The CMOS sensor may have defect pixels which cannot properly respond to the light. The VP-71MC camera provides a feature to correct the defect pixels to enhance the quality of output images. Defect pixel information of the CMOS used for each camera is saved in the camera during the manufacturing process in the factory. If you want to add defect pixel information, it is required to enter coordinate of new defect pixel into the camera. You can determine whether to use the Defective Pixel Correction feature by using the 'sdc' command. For more information, refer to [Appendix A](#).

### 8.7.1 Correction Method

Correction value for a defect pixel is calculated based on valid pixel value adjacent in the same line.

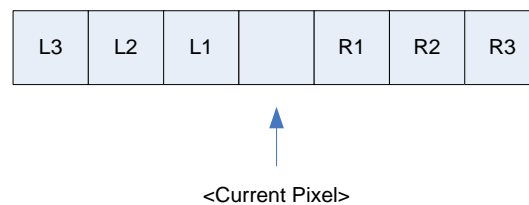

**Figure 8.11 Location of Defect Pixel to be corrected**

If the current pixel is a defect pixel as shown in the figure above, correction value for this pixel is obtained as shown in the following table depending on whether adjacent pixels are defect pixel or not.

Adjacent Defect Pixel (s)	Correction Value of Current Pixel
없음	$(L1 + R1) / 2$
L1	R1
R1	L1
L1, R1	$(L2 + R2) / 2$
L1, R1, R2	L2
L2, L1, R1	R2
L2, L1, R1, R2	$(L3 + R3) / 2$
L2, L1, R1, R2, R3	L3
L3, L2, L1, R1, R2	R3

**Table 8.5 Calculation of Defect Pixel Correction Value**

## 8.8 Flat Field Correction

The Flat Field Correction feature improves the image uniformity when you acquire a non-uniformity image due to external conditions. The Flat Field Correction feature can be summarized by the following equation:

$$IC = IR / IF$$

IC: Level value of corrected image

IR: Level value of original image

IF: Level value of Flat Field data

In the actual use conditions, generate a Flat Field data (IF) and enable the Flat Field Correction feature according to the following procedures.

1. Execute the Flat Field Generator by using the 'gfd' command. The Flat Field Generator will average series of frames and scale down to 1/32 pixel to generate the Flat Field data. The Flat Field data will be saved in the external frame buffer (volatile memory).
2. Enable the Flat Field Correction feature by using the 'sfc' command. The Flat Field data will be enlarged via Bilinear Interpolation as shown in the Figure 8.13.
3. Save the generated Flat Field data in the non-volatile memory by using the 'sfd' command for future use.



- It is recommended that you enable the Defective Pixel Correction feature before executing the Flat Field Generator.
- Executing the Flat Field Generator will temporarily set the camera's ROI to its full resolution. After completing the Flat Field data generation, the previous camera settings will be restored.
- You need to operate the camera with Free-Run mode or apply a trigger signal to acquire an image.

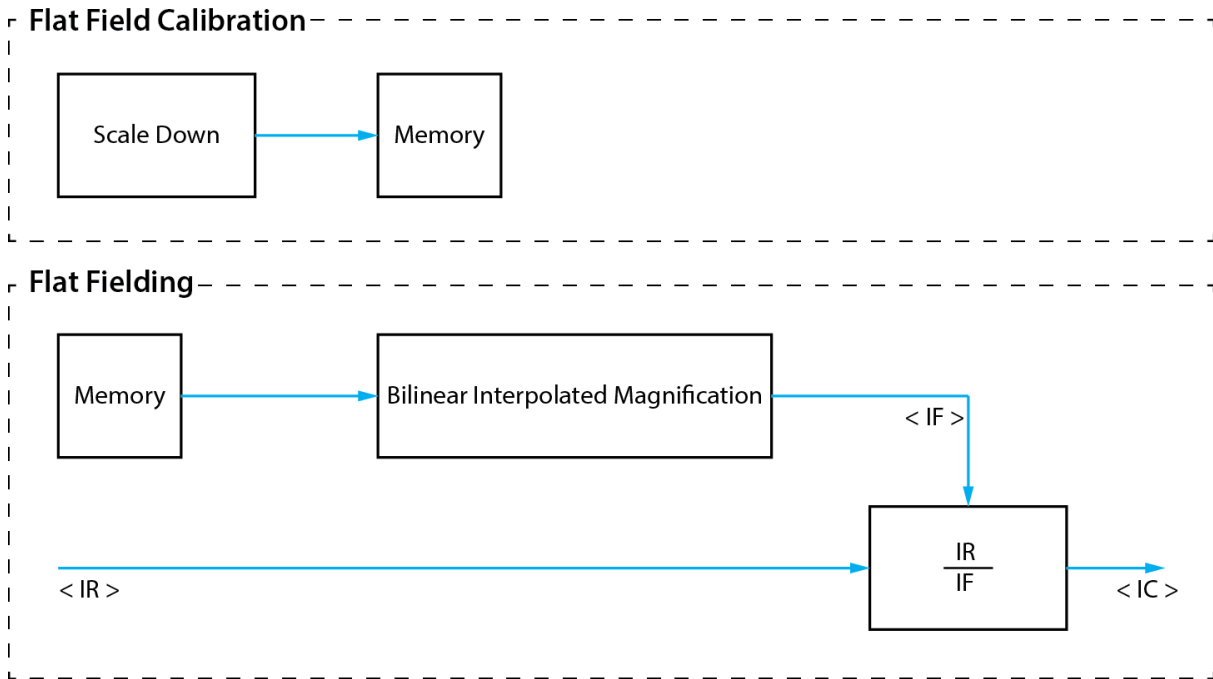

Figure 8.12 Generation and Application of Flat Field Data

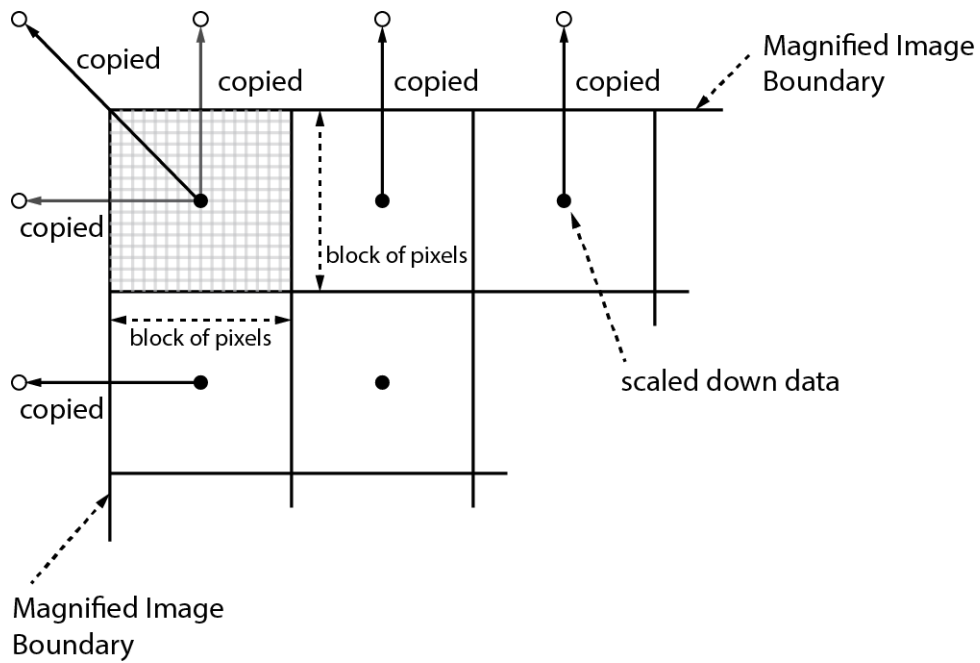

Figure 8.13 Bilinear Interpolated Magnification

## 8.9 Dark Image Correction

The CMOS sensor may result in lower sensitivity at dark level. This is caused by fixed pattern noise variation depending on the exposure settings or characteristic changes according to the temperature variation of AFE and sensor cell. Sensitivity changes caused by the temperature variation are less than 1 dB/10 degree. The acquisition condition of correction data is 25 degree based on the camera case temperature. To acquire optimized image at user environment, it is recommended to perform dark image correction after the camera is installed and the temperature of the camera is stabilized.

### 8.9.1 Sequence of Dark Image Correction

#### How to correct Dark Image using Configurator

1. Prevent penetration of light into the camera's imaging sensor.
2. Click the **Generate Data** button in the **VIEW** tab to generate correction data.
3. Click the **Save Data** button to save correction data in the flash memory. The saved data will be applied to the camera automatically when the camera is powered on.

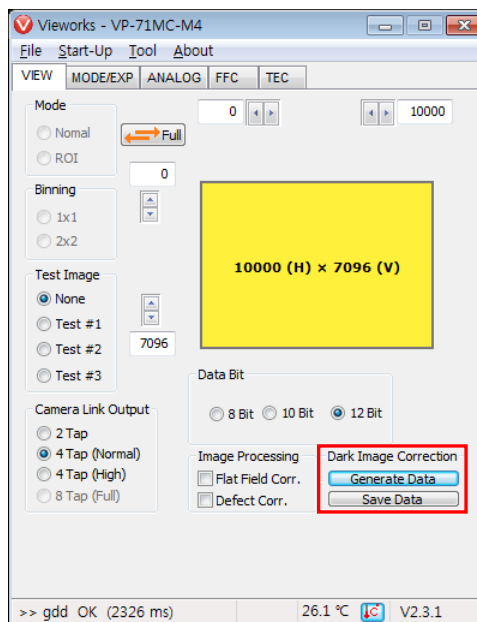

Figure 8.14 Dark Image Correction in Configurator

#### How to correct Dark Image using Serial Command

1. Prevent penetration of light into the camera's imaging sensor.
2. Use the 'gdd' command to generate correction in the camera.
3. Use the 'sdd' command to save correction data in the flash memory.

## 8.10 White Pixel

If you use the VP-71MC camera under the condition of high ambient temperature, white pixels (also known as 'hot pixels') may be appeared due to the characteristic of the high resolution CMOS imaging sensor.

White pixels are caused by accumulated current leakage in the charge storage region inside the imaging sensor's active pixel. If the temperature of the camera is increased by seven degrees, it is getting worse with double white pixels. To effectively reduce white pixels, maintain the operating temperature as low as possible and mount the camera on a substantial metal component in your system to provide sufficient heat dissipation. You can also use the defective pixel correction feature to remove white pixels. Add a defect pixel to the defect pixel map or modify the defect pixel map stored in the camera.

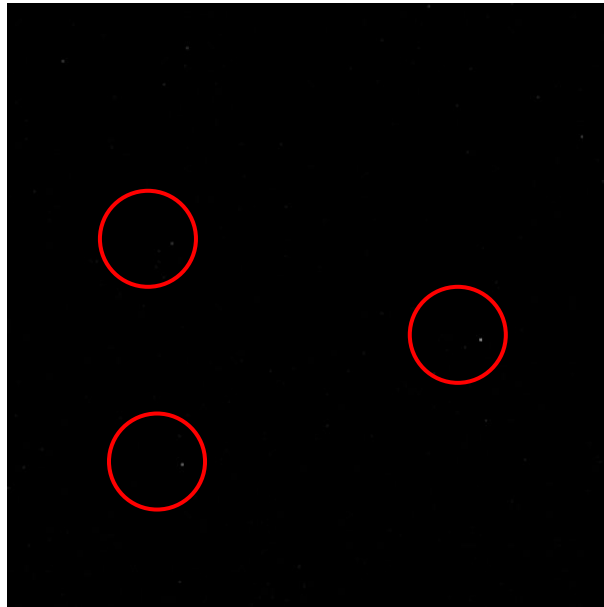

**Figure 8.15 White Pixel**



## 8.11 Auto White Balance

The Auto White Balance feature is implemented on the VP-71MC-C4 color camera. It will control the white balance of the image acquired from the color camera according to the Grey World algorithm. The entire pixel data of the imaging sensor will be used to control the white balance. When you activate the Auto White Balance feature, the gain value for the Digital Red, Digital Green and Digital Blue will be set to 1. Then the gain value for the Digital Red and Digital Blue will be adjusted to control the white balance of the image. You can set the Auto White Balance feature by using the 'arg' command.

## 8.12 Temperature Monitor

The camera has an embedded sensor chip to monitor the internal temperature. You can check the temperature of the camera by using the 'gct' command.

## 8.13 Status LED

A LED is installed on the back panel of the camera to inform the operation status of the camera. LED status and corresponding camera status are as follows:

- Continuous On: operates in the Free-Run mode.
- Repeat On for 0.5 second, Off for 0.5 second: operates in the External Sync mode.
- Repeat On for 1 second, Off for 1 second: outputs Test Image.
- Repeat On for 0.25 second, Off for 0.25 second: operates in the External Sync and outputs Test Image.

## 8.14 Data Format

The VP-71MC camera processes image data in the unit of 12 bit. You can determine the Data Format (8 bit, 10 bit or 12 bit) of image data transmitted from the camera by using the 'sdb' command. When the camera is set for 8 bit or 10 bit data format, the 4 or 2 least significant bits will be dropped from overall 12 bits.

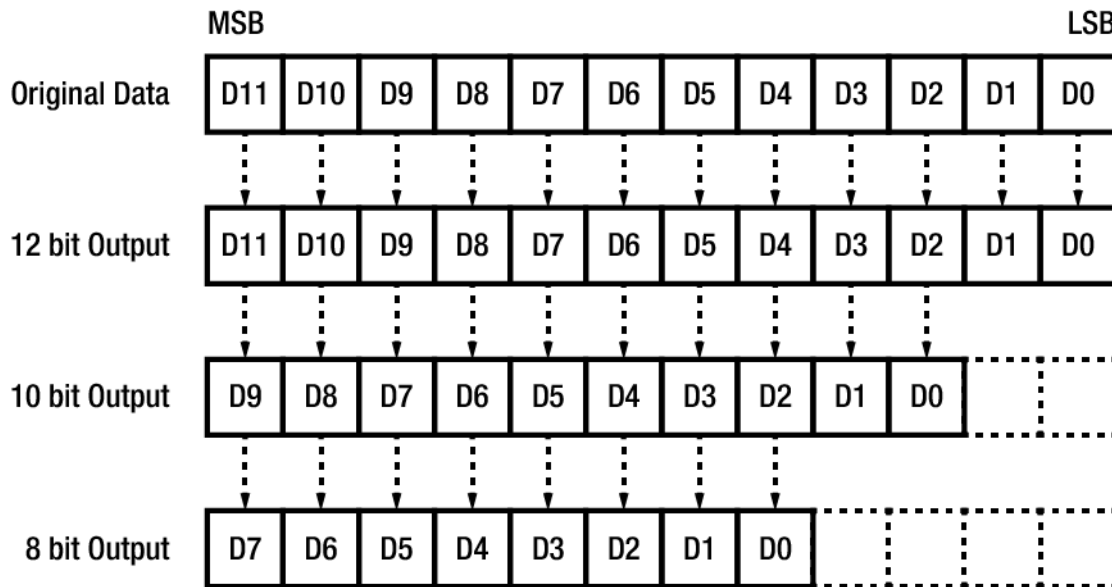

Figure 8.16 Data Format

## 8.15 Test Image

To check normal operation of the camera, it can be set to output test images created inside, instead of image data from the imaging sensor. There are three types of test images; image with different value in horizontal direction (Test Image 1), image with different value in diagonal direction (Test Image 2), and moving image with different value in diagonal direction (Test Image 3). The Test Image feature is available in all operation modes of the camera. You can set the Test Image feature by using the 'sti' command.

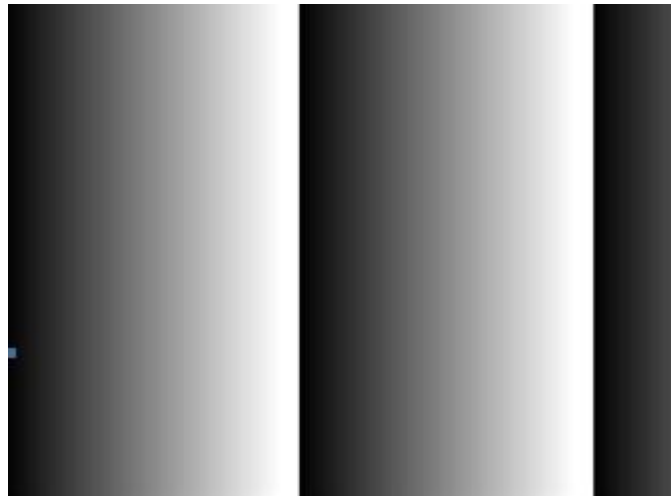

Figure 8.17 Test Image 1

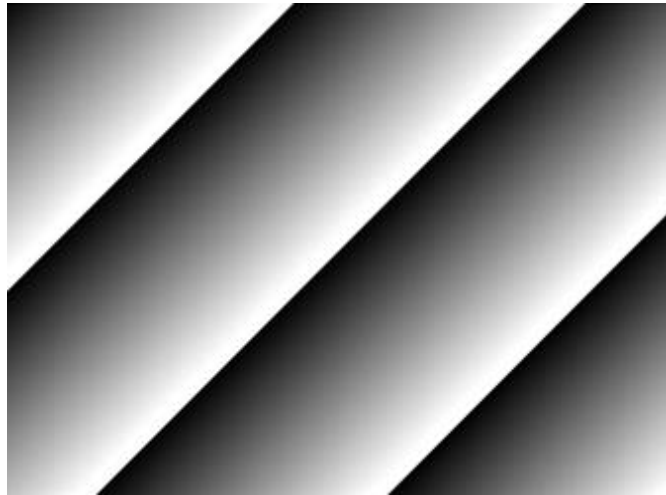

Figure 8.18 Test Image 2

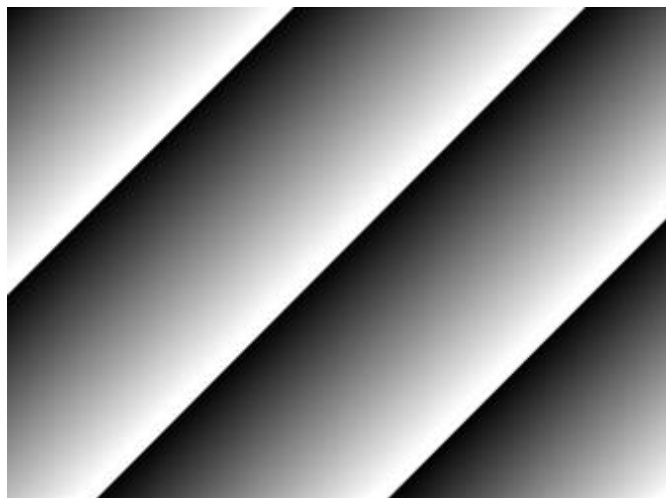

Figure 8.19 Test Image 3



The test image may look different because the region of the test image may vary depending on the camera's resolution settings.

## 8.16 Strobe

The Strobe signal goes high when the exposure time for each frame acquisition begins and goes low when the exposure time ends. This signal can be used as a flash trigger and is also useful when you are operating a system where either the camera or the object being imaged is movable. Typically, you do not want the camera to move during exposure. You can monitor the Strobe signal to know when exposure is taking place and thus know when to avoid moving the camera.

### 8.16.1 Strobe Type

The VP-71MC camera provides two types of the Strobe signal; **Wide Output** and **Narrow Output**.

The Wide Strobe signal goes high when the exposure time for the top line of pixels begins and goes low when the exposure time for the bottom line of pixels ends. The Narrow Strobe signal goes high when the exposure time for the bottom line of pixels begins and goes low when the exposure time for the top line of pixels ends.

Then Narrow Strobe signal is only available when the exposure time is longer than the readout time and is useful when you are operating the camera under the flash lighting conditions.

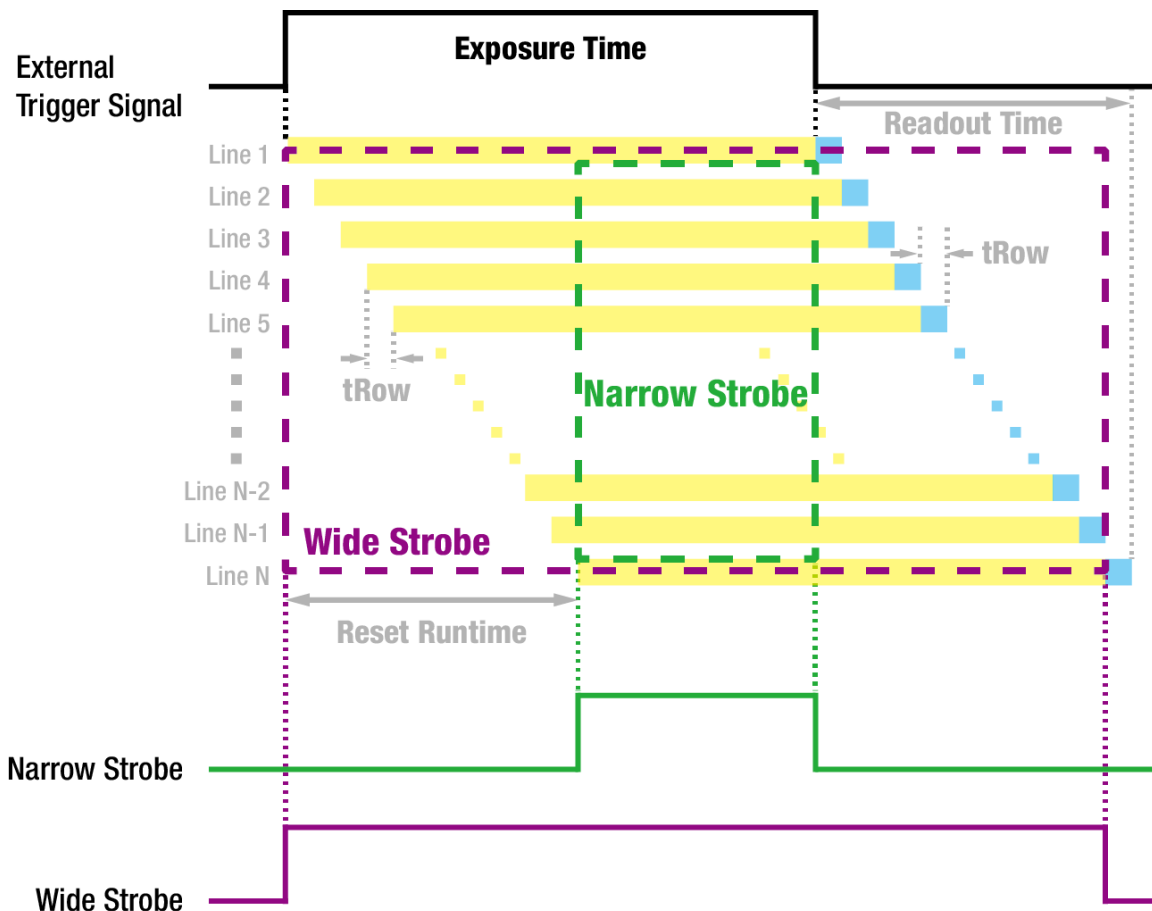

Figure 8.20 Strobe Type

## 8.16.2 Strobe Polarity

After setting the **Strobe Type**, you must set the **Strobe Polarity**. You can set the polarity of the strobe signal by using the 'ssp' command.

The available settings for the Strobe Polarity are:

- **Active Low:** Specifies that a falling edge of the strobe output signal will be valid.
- **Active High:** Specifies that a rising edge of the strobe output signal will be valid.

## 8.17 Field Upgrade

The camera provides a feature to upgrade Firmware and FPGA logic through the Camera Link interface rather than disassemble the camera in the field. Refer to [Appendix B](#) for more details on how to upgrade.

## 9 Camera Configuration

### 9.1 Setup Command

You can configure all camera settings via RS-644 serial interface of the Camera Link. When you want to control the camera using a terminal or to access directly to the camera at your application, you need to set your network as follows:

- Baud Rate: 115200 bps
- Data Bit: 8 bit
- Parity Bit: No Parity
- Stop bit: 1 stop bit
- Flow control: None

All camera setting commands are transmitted in the ASCII command type except a command for transmitting a large file such as firmware download. All camera setting commands are transmitted from the user application and then the camera returns a response ("OK", "Error" or information) for a command. When you execute a write command, the camera returns a response to inform whether the command has been successfully executed. When you execute a read command, the camera returns an error or information.

```
Command format:
<command> <parameter1> <parameter2> <cr>
0 - 2 parameters follow the command.
Response:
- If a write command is successfully executed
OK <cr> <lf>
```

ex) Write command

```
In response to a "set 100" command the camera will return (in hex value)
Command   : 73 65 74 20 31 30 30 0D
           set 100<cr>
Response  : 73 65 74 20 31 30 30 0D 0A 4F 4B 0D 0A 3E
           set 100<cr><lf>          OK<cr><lf>  >
Echo      :                               result  prompt
```

```
If a read command is successfully executed  
<parameter1> <cr> <lf>
```

ex) Read command

```
In response to a "get" command the camera will return (in hex value)  
Command   : 67 65 74 0D  
           get <cr>  
Response  : 67 65 74 0D 0A 31 30 30 0D 0A 3E  
           get<cr><lf>    100<cr><lf>    >  
           Echo          response      prompt
```

```
If a command is not executed successfully  
Error : <Error Code> <cr> <lf>
```

```
Prompt:  
A prompt always follows after the response. '>' is used as prompt.
```

Types of Error Code

```
0x80000481: value of parameter is not valid  
0x80000482: the number of parameter is not matched  
0x80000484: command does not exist  
0x80000486: no permission to execute
```



## 9.2 Actual Time Applied for Commands

When you execute a command, the actual runtime of the command varies depending on the type of the command and the operating status of the camera.

All commands except Set Exposure Time ('set') command are applied to change the settings as illustrated below, on the rising edge of a VCCD signal before starting the readout process. When you execute the 'set' command, the exposure time setting will be changed and applied at the starting of the exposure.

If you operate the camera with CC1 or external trigger signals, you must execute commands before applying the trigger signals in order to synchronize image outputs with the commands.

If you execute a command in the Free-Run mode, you may acquire up to two images that are not affected by the command execution. This is true because it is hard to verify the current operating status of the camera in the Free-Run mode.

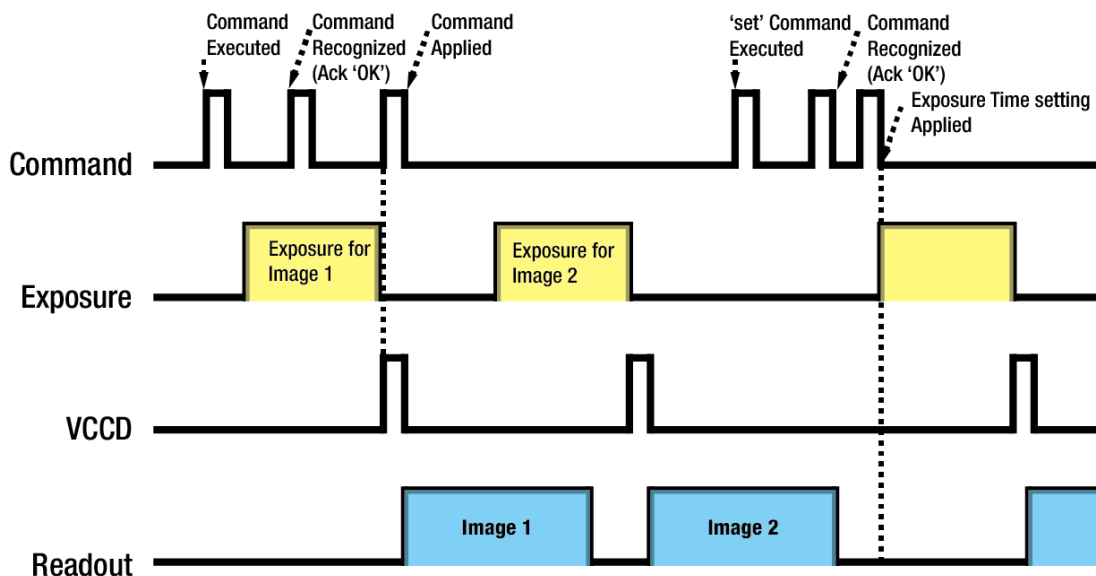

Figure 9.1 Actual Time Applied for Commands

## 9.3 Parameter Storage Space

The camera provides three non-volatile spaces for storing parameter settings and one volatile work space. The work space contains the camera's current parameter settings. Non-volatile spaces are divided into Factory Space that contains default values entered during the manufacturing, and two user spaces (User 1 Space and User 2 Space) that are available for saving parameter settings by users. Read and write operations are allowed in the user spaces, but only the read operations are allowed in the factory space.

When the camera is powered on or reset, parameter settings stored in one of the storage spaces are loaded into the work space according to the Config Initialization value. These parameter settings will then determine the camera's performance.

The parameter settings in the work space are lost when the camera is powered off or reset. The camera can save parameter settings from the work space to a user space in the camera's non-volatile spaces.

The parameter settings stored in the non-volatile spaces are not lost when the camera is powered off or reset. You can save the current parameter settings to User 1 Space or User 2 Space by using the 'sct' command for future use.

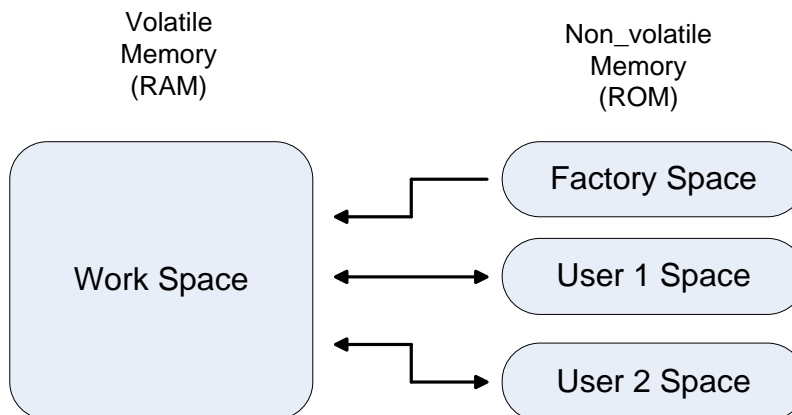

Figure 9.2 Parameter Storage Space

## Factory Setting Values

List	Value	Command
Data Bit	12	sdb 12
Trigger Mode	free-run	stm 0
Exposure Time	10.09 ms	set 10009
Exposure	Pulse Width	ses 1
Trigger Source	CC1 port	sts 1
Polarity	Active High	stp 1
Video Gain	0	sag 0
Video Offset	0	sao 0
Defect Correction	On	sdc 1
Camera Link Output	4 Tap (High)	scl 2
Strobe Type	Wide Output	ssc 0
Strobe Polarity	Active High	ssp 1
Fan Control	On	sft 1
Peltier Control	On	stc 1

**Table 9.1 Factory Setting Values**

## 9.4 Command List

You can set all features provided by the VP-71MC camera by using the following commands.

Command	Syntax	Value Returned	Description
Help	help	String	Displays a list of all commands
Set Width	siw n	OK	Width of ROI
Get Width	giw	n	n: Width value
Set Height	sih n	OK	Height of ROI
Get Height	gih	n	n: Height value
Set Offset X	sox n	OK	X coordinate of start point ROI
Get Offset X	gox	n	n: X axis offset
Set Offset Y	soy n	OK	Y coordinate of start point ROI
Get Offset Y	goy	n	n: Y axis offset
Set Trigger Mode	stm 0 1	OK	Sets the Trigger Mode
Get Trigger Mode	gtm	0 1	0: Free Run mode 1: External Sync mode
Set Exposure Source	ses 0 1	OK	Sets the Exposure Mode
Get Exposure Source	ges	0 1	0: Program – Exposure Time parameter 1: Pulse Width – Width of signal
Set Trigger Source	sts 1 2	OK	Specifies a source signal in External Sync
Get Trigger Source	gts	1 2	1: CC1 port 2: External port
Set Trigger Polarity	stp 0 1	OK	Specifies a polarity of trigger in External Sync
Get Trigger Polarity	gtp	0 1	0: Active Low 1: Active High
Set Exposure Time	set n	OK	Sets an exposure time (Free-Run and Program)
Get Exposure Time	get	n	n: exposure time in microseconds ( $\mu$ s)
Set Analog Gain	sag n	OK	Sets the Digital Video Gain
Get Analog Gain	gag	n	n: Gain value (Setting Range: 0 ~ 63)
Set Analog Offset	sao n	OK	Sets the Digital Video Offset
Get Analog Offset	gao	n	n: Offset value (Setting Range: 0 ~ 63)

**Table 9.2 Command List #1**

Command	Syntax	Value Returned	Description
Set Test Image Get Test Image	sti 0 1 2 3 gti	OK 0 1 2 3	Sets the Test Image 0: Test Image Off 1, 2: Fixed pattern images 3: Moving pattern image
Set Data Bit Get Data Bit	sdb 8 10 12 gdb	OK 8 10 12	Sets the Data Format 8: 8 Bit 10: 10 Bit 12: 12 Bit
Set Camera-Link Mode Get Camera-Link Mode	scl 0 1 2 gcl	OK 0 1 2	Sets the Camera Link Output mode 0: 2 Tap 1: 4 Tap (Normal Speed - 60 MHz) 2: 4 Tap (High Speed - 85 MHz)
Set Strobe Control Get Strobe Control	ssc 0 1 gsc	OK 0 1	Sets the Strobe Type 0: Wide 1: Narrow
Set Strobe Polarity Get Strobe Polarity	ssp 0 1 gsp	OK 0 1	Sets the Strobe Polarity 0: Active Low 1: Active High
Generate Flat Field Data	gfd	OK	Executes the Flat Field Generator
Save Flat Field Data	sfd	OK	Saves the generated Flat Field data in the non-volatile memory
Load Flat Field Data	lfd	OK	Loads the Flat Field data from the non-volatile memory into the volatile memory
Set Flat Field Correction Get Flat Field Correction	sfc 0 1 gfc	OK 0 1	Enables the Flat Field Correction feature 0: Off 1: Activate the Flat Field Correction feature
Set Defect Correction Get Defect Correction	sdc 0 1 gdc	OK 0 1	Enables the Defective Pixel Correction feature 0: Off 1: Activate the Defective Pixel Correction

Table 9.3 Command List #2

Command	Syntax	Value Returned	Description
Save Config. To	sct 1 2	OK	Saves the current camera setting values 1: Saves to User 1 space 2: Saves to User 2 space
Load Config. From	lcf 0 1 2	OK	Loads camera setting values 0: Loads from Factory space 1: Loads from User 1 space 2: Loads from User 2 space
Set Config Initialization Get Config Initialization	sci 0 1 2 gci	OK 0 1 2	Specifies setting values to be loaded when reset 0: Applies Factory default settings 1: Applies User 1 settings 2: Applies User 2 settings
Get Model Name	gmn	String	Displays camera model name
Get MCU Version	gmv	String	Displays the version of camera MCU
Get FPGA Version	gfv	String	Displays the version of camera FPGA
Get Serial Number	gsn piece	String	Displays the serial number of the camera
Get Current Temperature	gct	String	Displays device temperature in Celsius
Set RGB Gain Get RGB Gain	srg r b f grg r b	OK f	Sets the RGB Gain value r: Red among RGB b: Blue among RGB f: Gain value
Auto generation RGB Gain	arg	OK	Executes the Auto White Balance feature
Set Fan Control Get Fan Status	sft 0 1 gft	OK 0 1	Control Fan On/Off 0: Fan Off 1: Fan On
Set Peltier Control Get Peltier Control	stc 0 1 gtc	OK 0 1	Control Peltier On/Off 0: Peltier Off 1: Peltier On

Table 9.4 Command List #3

## 10 Configurator GUI

Configurator, a sample application, is provided to control VP-71MC camera. Configurator provides easy-to-use Graphic User Interface (GUI) that allows users to view and change the camera's settings mentioned in the previous chapters.

### 10.1 Camera Scan

When you execute the Configurator.exe file while the camera is powered on, the **Camera Scan** window appears as shown in the figure below. At this time, the Configurator checks serial ports of your computer and DLL provided by the Camera Link to scan whether a camera is connected. If the Configurator finds a connected camera, it displays the model name of the camera on the Camera Scan window. If the camera is not displayed on the window, check the cable connections and power of the camera, and then press the **refresh** button. Double-clicking the model name of the camera displayed on the window will launch the Configurator and display the current parameter settings of the camera connected.

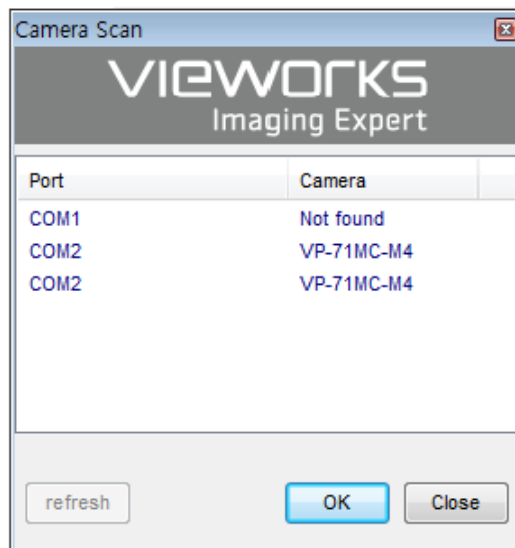

Figure 10.1 Configurator Loading Window

## 10.2 Menu

### 10.2.1 File

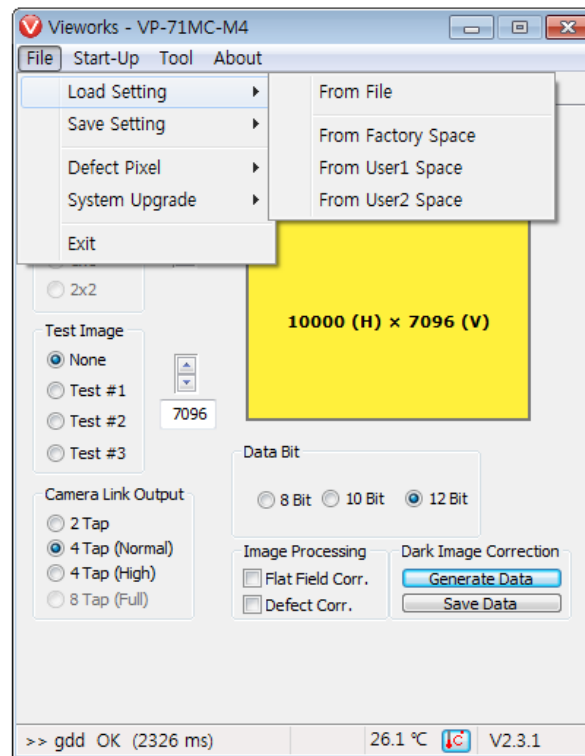

Figure 10.2 File Menu

- **Load Setting:** Loads the camera setting values from the camera memory (Factory, User1 or User2) or user's computer (From File).
- **Save Setting:** Saves the camera setting values to the camera memory (User1 or User2) or user's computer (To File).
- **Defect Pixel:** Downloads defect information to the camera (Download to Camera) or uploads defect information stored in the camera to user's computer (Upload to PC).
- **System Upgrade:** Upgrades MCU or FPGA logic.
- **Exit:** Exits the Configurator.



## 10.2.2 Start-Up

You can select the camera setting values to load when the camera is powered on.

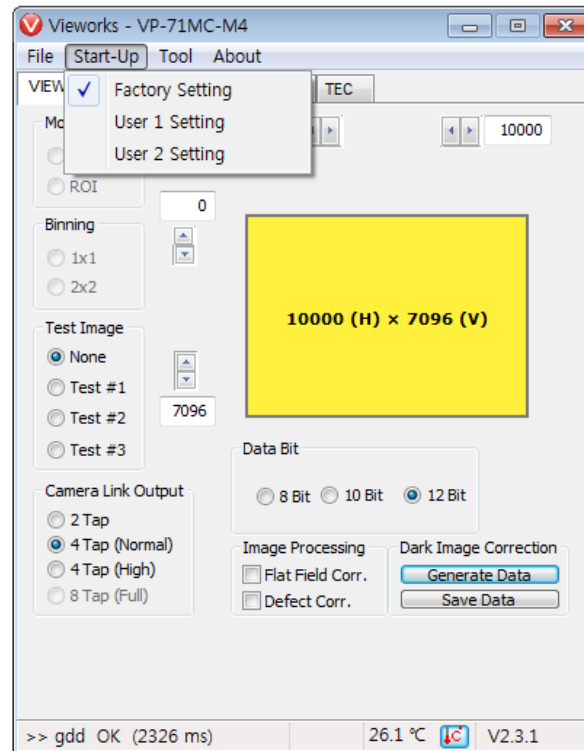

**Figure 10.3 Start-Up Menu**

- **Factory Setting:** Loads the camera setting values from Factory Space.
- **User1 Setting:** Loads the camera setting values from User1 Space.
- **User2 Setting:** Loads the camera setting values from User2 Space.

## 10.2.3 Tool

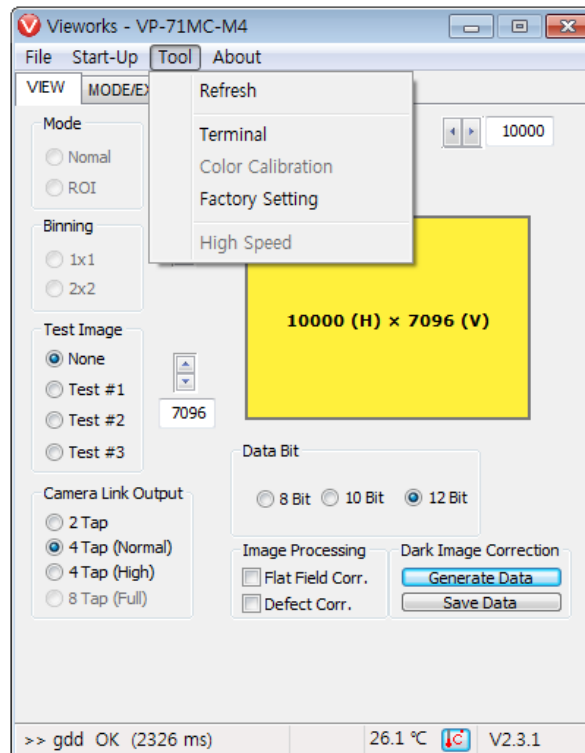

Figure 10.4 Tool Menu

- **Refresh:** Loads and displays the current camera setting values on Configurator.
- **Terminal:** Displays user commands in the Terminal window under the GUI. To hide the Terminal window, uncheck Terminal by clicking again.
- **Color Calibration:** Displays the **Color Calibration** window for Bayer sensor color temperature calibration. When you click the **Auto White Balance** button, white balance is adjusted once and then Off.

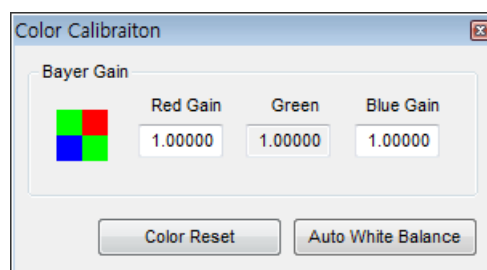
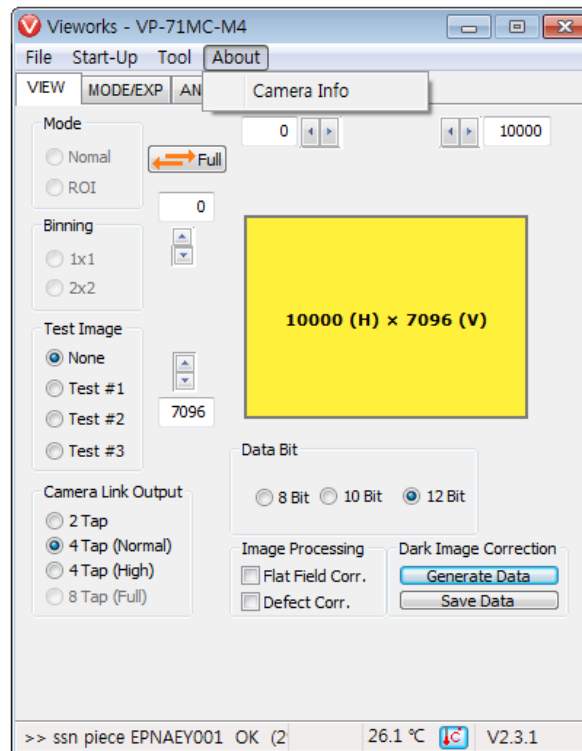

Figure 10.5 Color Calibration (Color Camera Only)

- **Factory Setting:** Not supported for users.
- **High Speed:** Not supported on the VP-71MC.

## 10.2.4 About



**Figure 10.6 About Menu**

- **Camera Info:** Displays camera information (model name, serial number, version, etc.).

## 10.3 Tab

### 10.3.1 VIEW Tab

The VIEW tab allows you to set the camera's region of Interest (ROI), test image mode, data bit, Camera Link output, image processing, dark image correction, etc.

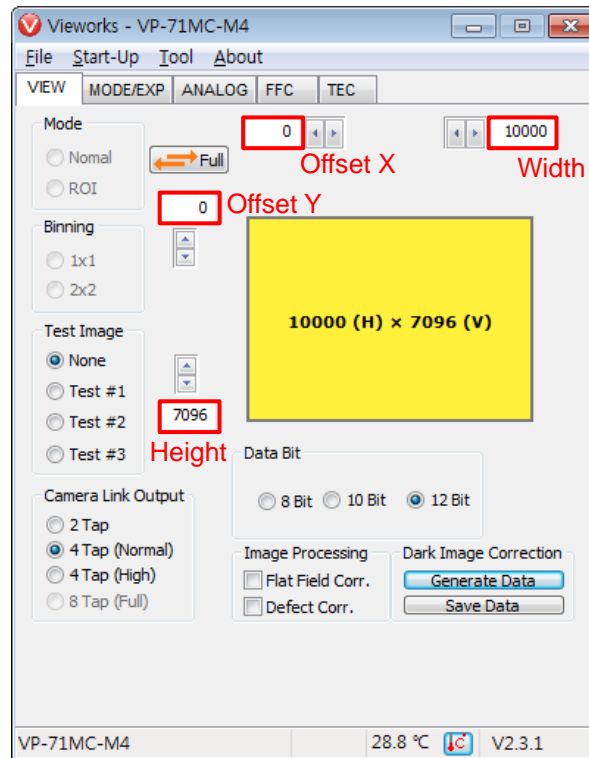
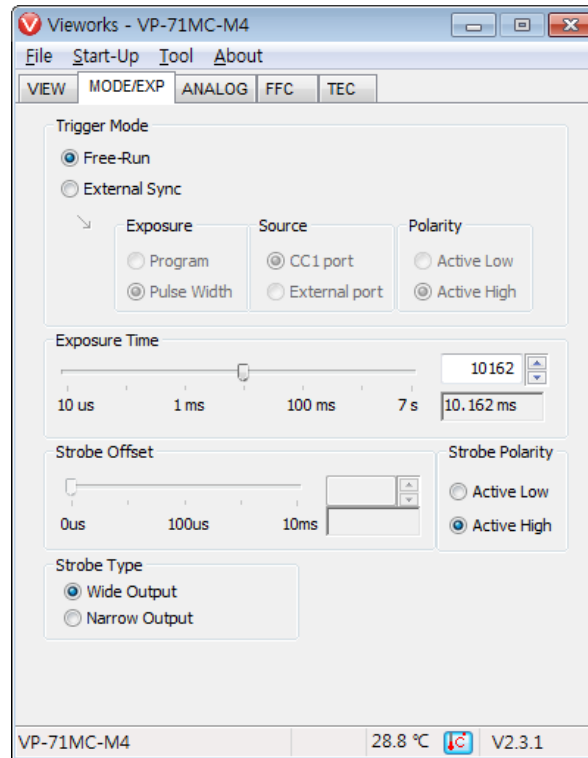

**Figure 10.7 VIEW Tab**

- **ROI:** Sets the camera's ROI by using the Offset X, Width, Offset Y and Height input box. Click the **Full** button to set the camera's ROI to its full resolution.
- **Test Image:** Selects whether to apply test image and a type of test images.
- **Camera Link Output:** Selects a Camera Link Output mode.
- **Data Bit:** Selects a bit depth of data output.
- **Image Processing:** Sets the Flat Field Correction and Defect Correction features On or Off.
- **Dark Image Correction:** Corrects fixed pattern noise in dark images.

### 10.3.2 MODE/EXP Tab

The MODE/EXP tab allows you to configure the camera's Trigger Mode, exposure time and strobe. All scroll bars in the GUI are controllable with the mouse wheel scroll.

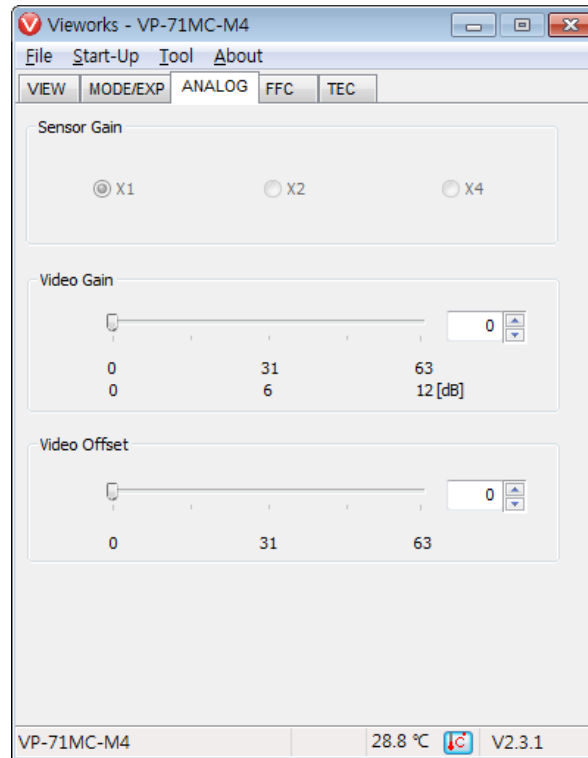

**Figure 10.8 MODE/EXP Tab**

- **Trigger Mode:** Selects a Trigger Mode. Once you select the External Sync mode, options related with the External Sync will be activated.
- **Exposure:** Selects an exposure source.
- **Source:** Selects a source signal for exposure triggering.
- **Polarity:** Selects a polarity of trigger signals.
- **Exposure Time:** Sets exposure time when the Trigger Mode is set to Free-Run or when Exposure is set to Program.
- **Strobe Type:** Selects a strobe type.
- **Strobe Polarity:** Selects a polarity of the Strobe output signal.

### 10.3.3 ANALOG Tab

The ANALOG tab allows you to adjust the camera's gain and offset settings. All scroll bars in the GUI are controllable with the mouse wheel scroll.



**Figure 10.9 ANALOG Tab**

- **Video Gain:** Sets a gain value.
- **Video Offset:** Sets an offset value.

### 10.3.4 FFC Tab

The FFC tab allows you to set the Flat Field Correction feature.

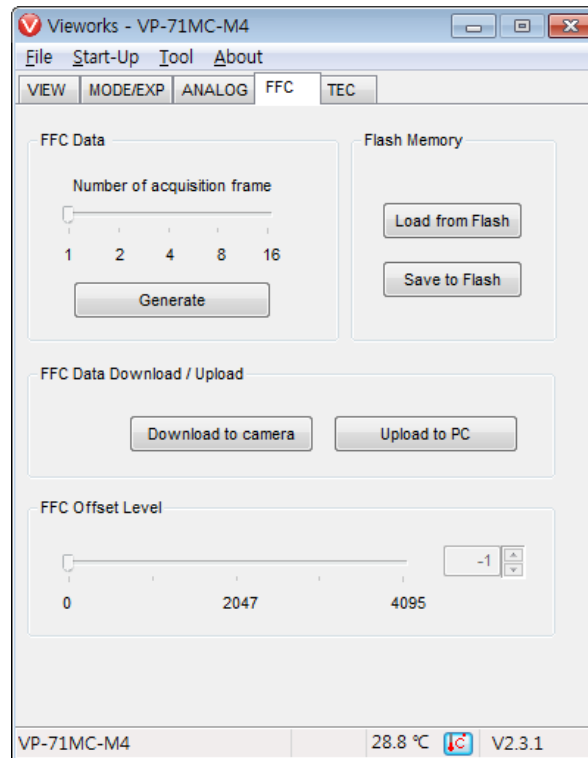

Figure 10.10 FFC Tab

- **FFC Data:** Clicking the **Generate** button will generate Flat Field Correction data.
- **Flash Memory:** Saves the generated FFC data in the Flash memory for future use (Save to Flash) or loads the FFC data stored in the Flash memory (Load from Flash).
- **FFC Data Download / Upload:** Downloads the FFC data stored in user's computer to the camera (Download to camera) or uploads the FFC data stored in the camera to user's computer (Upload to PC).

### 10.3.5 TEC Tab

The TEC tab allows you to control target temperature of the CCD imaging sensor.

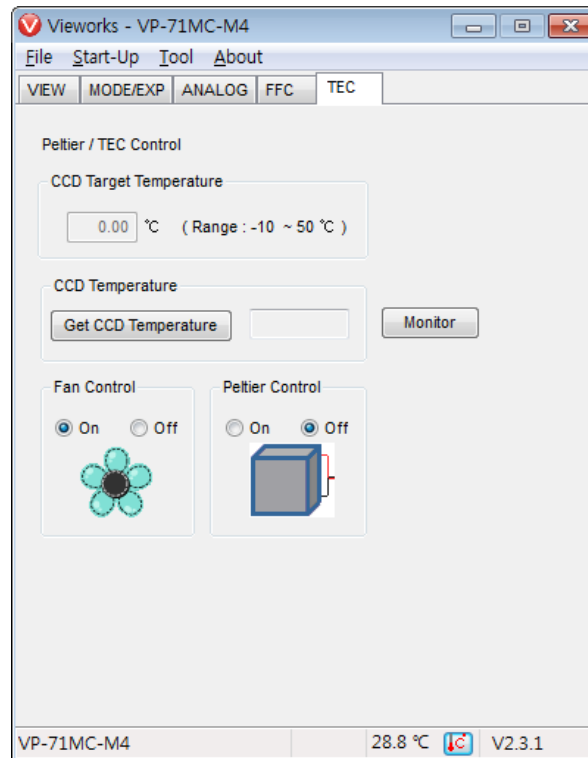

Figure 10.11 TEC Tab

- **CCD Target Temperature:** Sets target temperature of the CCD imaging sensor.
- **CCD Temperature:** Displays the current CCD imaging sensor's temperature.
- **Fan Control:** Turns the fan on or off.
- **Peltier Control:** Turns the Peltier on or off.



## 11 Troubleshooting

When you have a problem with a Vieworks camera, please check the followings:

- If no image is displayed on your computer,
  - Ensure that all cable connections are secure.
  - Ensure that the power supply is properly connected.
  - Ensure that trigger signals are applied correctly when you operate the camera with trigger signals.
- If images are not clear,
  - Ensure the camera lens or glass is clean.
  - Check the lens aperture is adjusted properly.
- If images are dark,
  - Ensure the camera lens is not blocked.
  - Check the exposure time is set properly.
  - Check the aperture is opened properly.
  - Check the Video Gain value is not set to small.
- If you identify abnormal operation or overheating sign,
  - Ensure the power supply is properly connected.
  - Stop using the camera when you notice smoke or abnormal overheating.
- If the External Sync mode is not working correctly,
  - Ensure that the CC1 settings on the frame grabber are configured correctly when you use CC1 triggering.
  - Ensure that cable connections are secure when you use external triggering.
- If there is a communication failure between the camera and user's computer,
  - Ensure that the Camera Link cable connections are secure.
  - Ensure that you have configured a frame grabber in your computer and the camera is connected to the frame grabber correctly.

## Appendix A Defective Pixel Map Download

1. Create a Defect Pixel Map in Microsoft Excel format as shown in the left picture below and save as a CSV (\*.csv). The picture in the right shows the created Excel file opened with Notepad. The following rules need to be applied when creating the file.
  - Lines beginning with ':' or '--' are treated as notes.
  - You must enter the horizontal value first and then the vertical value for coordinate of each defect pixel.
  - Coordinate values for each pixel can be placed in any order.

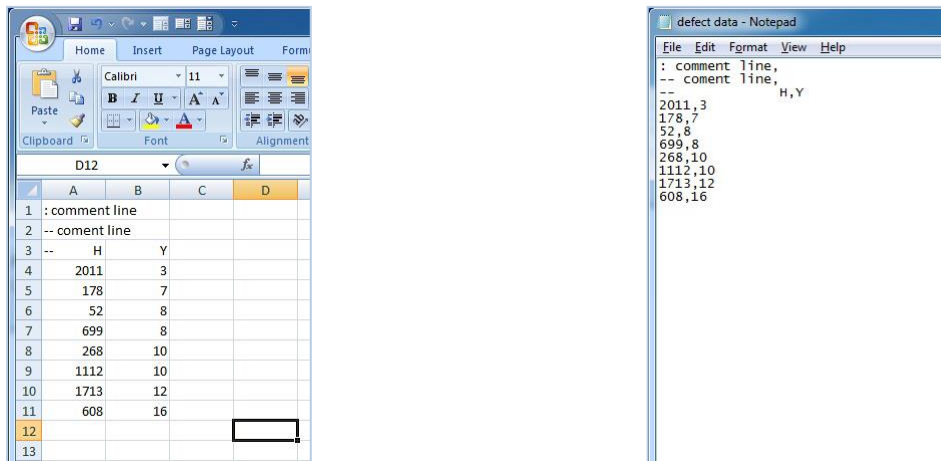

2. Select **File > Defect Pixel > Download to Camera** in the Configurator.

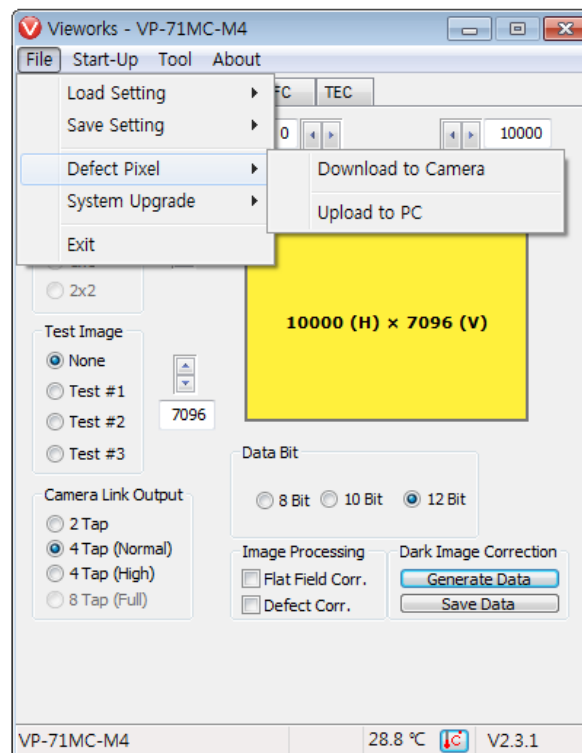

3. Search and select the created file and click **Open**.

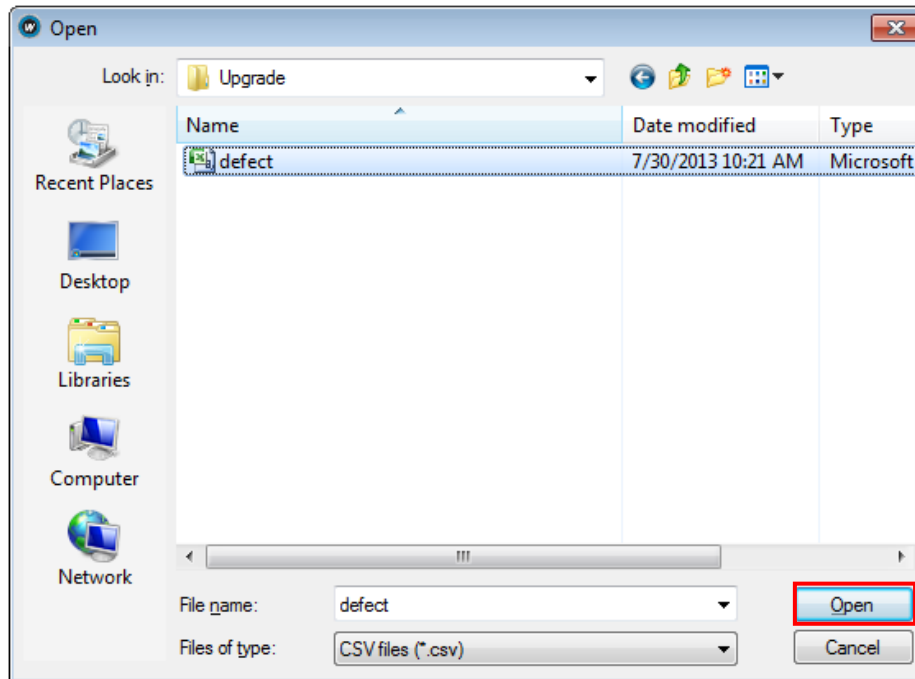

4. The Configurator starts downloading Defect Pixel Map to the camera and the downloading status is displayed at the bottom of the window.

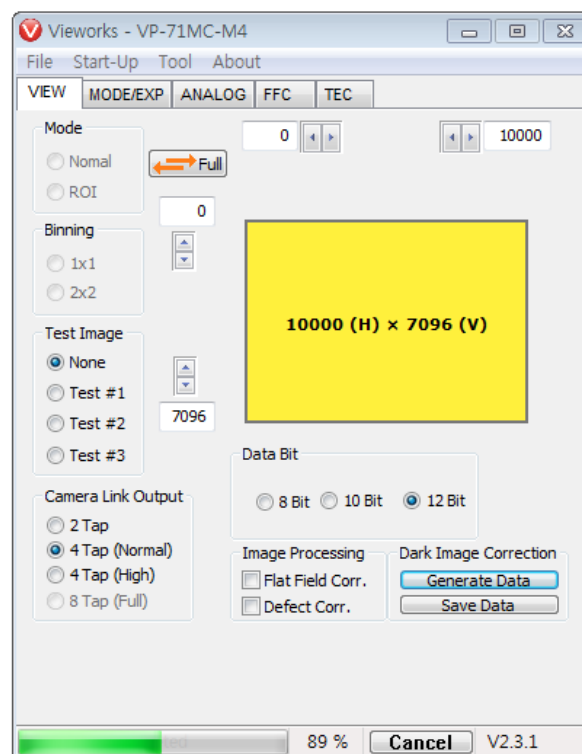

- Once the download is complete, the saving process will begin. During the saving process, make sure not to disconnect the power cord.

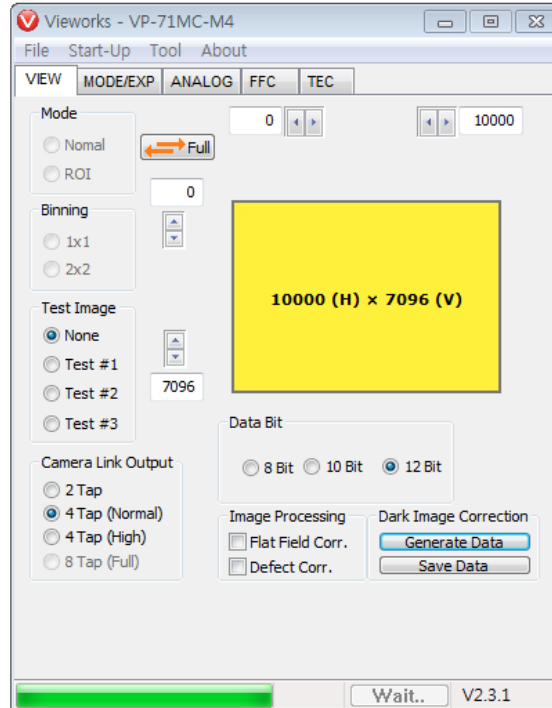

- Once all the processes are complete, **Download completed** message will appear at the bottom of the window.

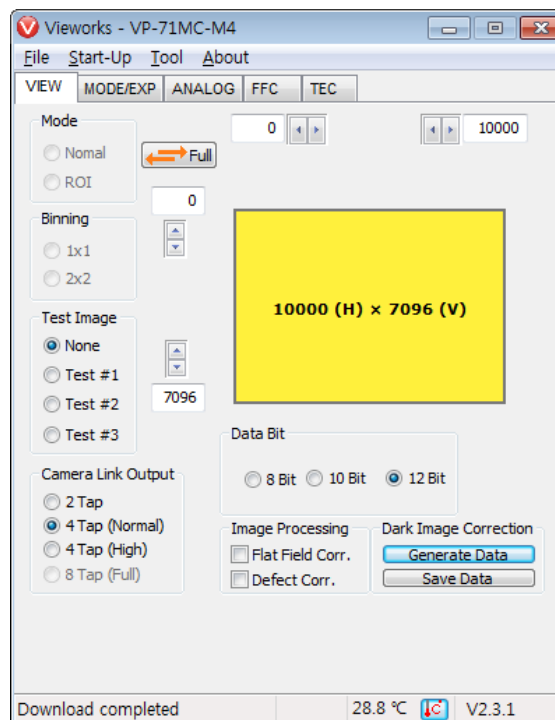

## Appendix B Field Upgrade

### B.1 MCU

1. Select **File > System Upgrade -> MCU Upgrade** in the Configurator.

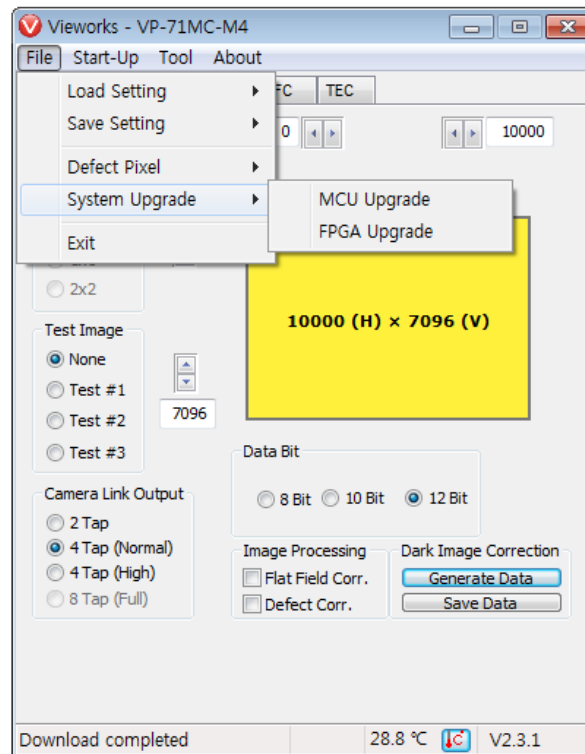

2. Search and select the provided MCU file (\*.mcu) and then click **Open**.

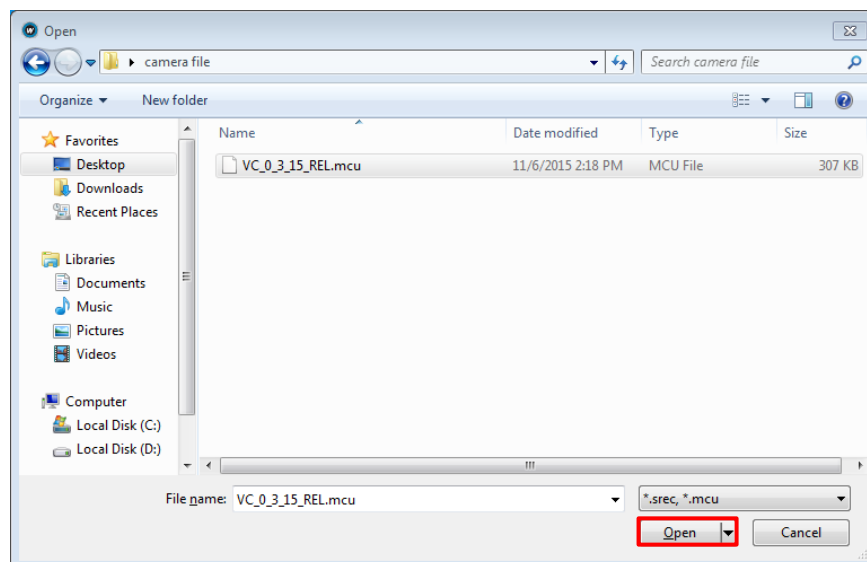

- The Configurator starts downloading MCU upgrade file to the camera and downloading status is displayed at the bottom of the window. If you want to cancel the upgrade process, click **Cancel**. This process may require several minutes to complete.

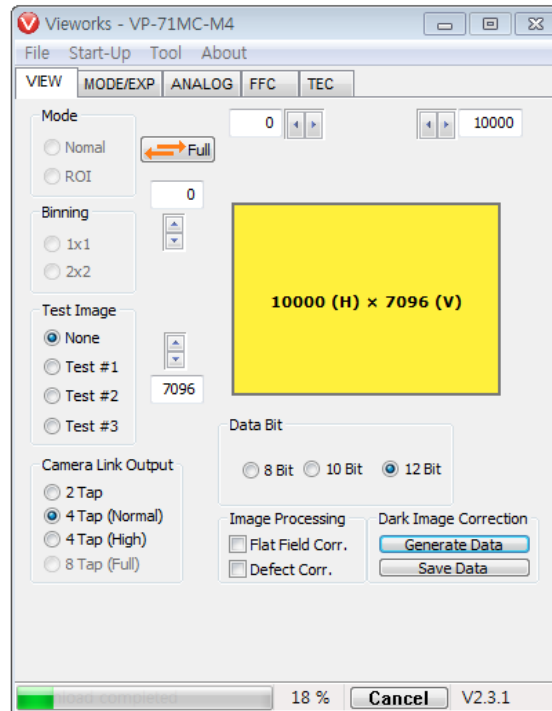

- Once the download is complete, the saving process will begin. If a power failure occurs during the saving process, the camera cannot be restored. Make sure that the power connection is secure.

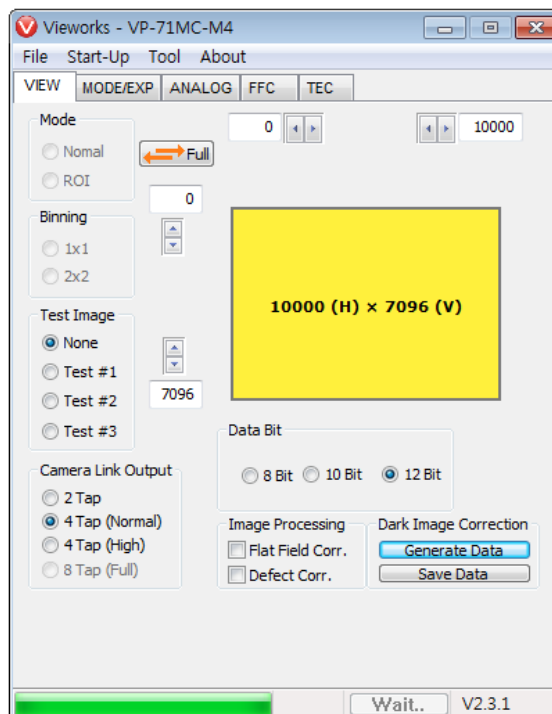

5. Once all the processes are complete, turn the camera power off and turn it back on again. Select **Tool > Terminal** and enter the 'gmv' command to confirm the version. Or, select **About > Camera Info** to confirm the MCU version.



## B.2 FPGA

1. Select **File > System Upgrade > FPGA Upgrade** in the Configurator.

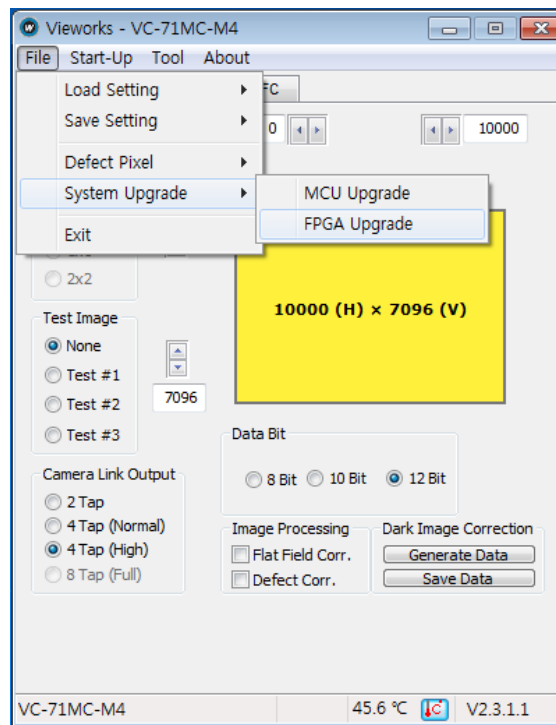

2. Search and select the provided FPGA upgrade file (\*.fpga) and click **Open**.

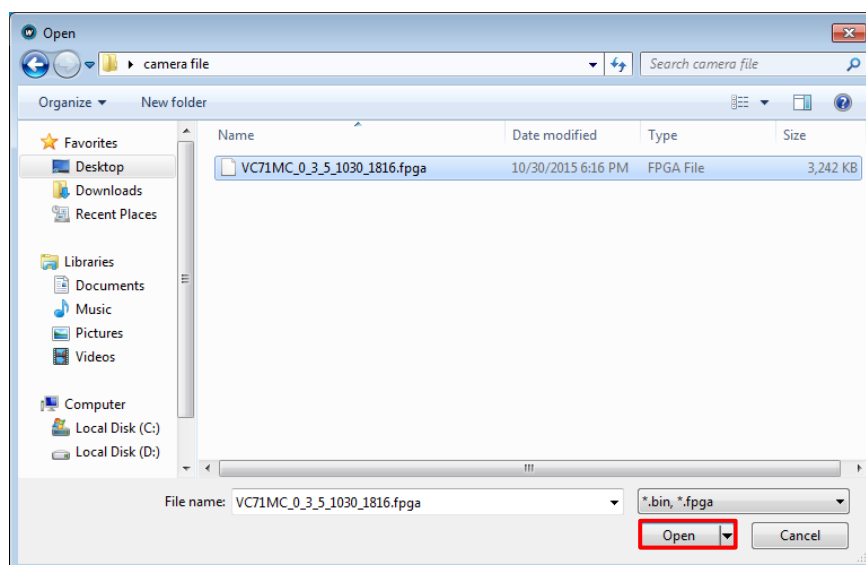

3. The subsequent processes are identical to those of MCU upgrade.



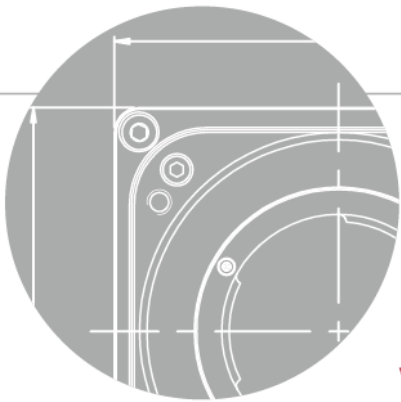
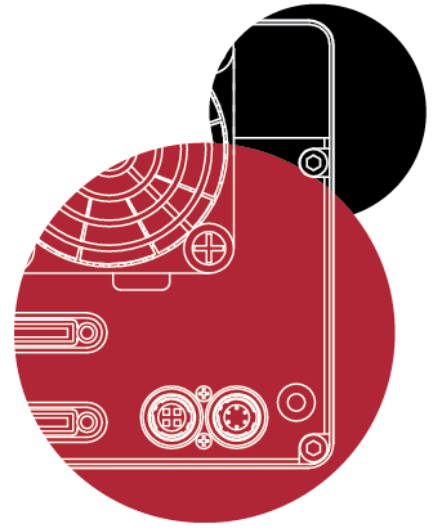
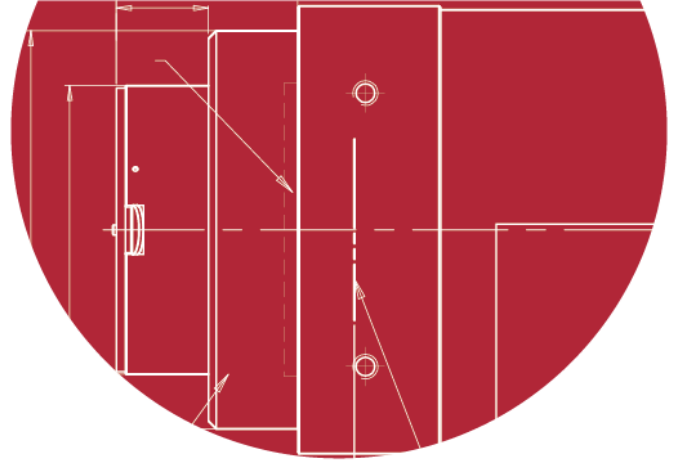

**Vieworks Co., Ltd.**

41-3, Burim-ro, 170beon-gil,  
Dongan-gu, Anyang-si, Gyeonggi-do  
14055 Republic of Korea

Tel: +82-70-7011-6161

Fax: +82-31-386-8631

<http://www.vieworks.com>

[vieworks@vieworks.com](mailto:vieworks@vieworks.com)