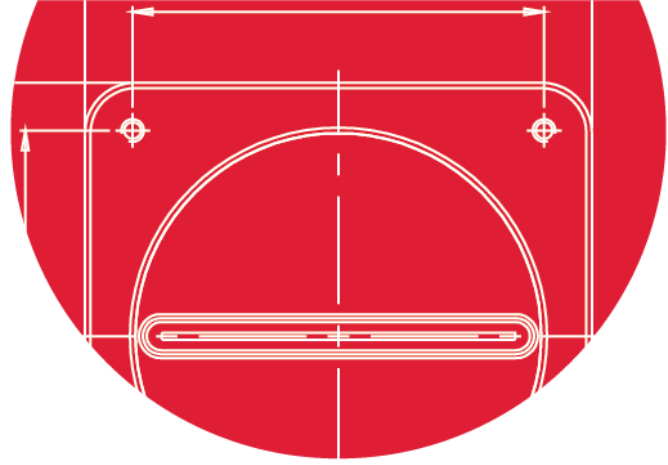


# VT series

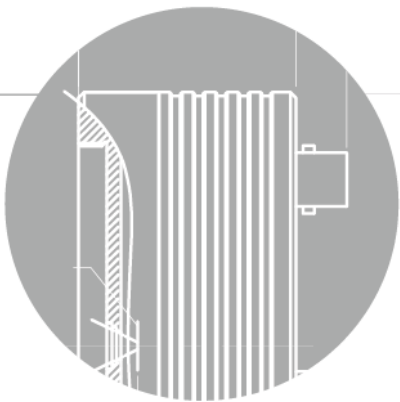
## User Manual



English

VT-3K7X  
VT-4K5X  
VT-6K3.5X  
VT-6K10X  
VT-9K7X  
VT-12K5X  
VT-16K5X  
VT-18K3.5X  
VT-23K3.5X

**CoaXPress**<sup>®</sup>



**VIEWWORKS**

## Revision History

Version	Date	Description
1.0	2016-03-18	Initial Release
1.1	2017-05-10	<p>Added the following models:</p> <ul style="list-style-type: none"> <li>• VT-3K7X-E250</li> <li>• VT-3K7X-H250</li> <li>• VT-4K5X-E200</li> <li>• VT-4K5X-H200</li> <li>• VT-6K3.5X-E160</li> <li>• VT-6K3.5X-H160</li> <li>• VT-16K5X-H140</li> <li>• VT-23K3.5X-H100</li> </ul>
1.2	2017-09-07	<ul style="list-style-type: none"> <li>• Added the values for the CXP Link Configuration Preferred Switch / CXP Link Configuration parameters</li> <li>• Updated camera mechanical dimensions (Added a connector for Strobe Controller)</li> <li>• Added the Trigger Statistics feature</li> <li>• Added the Lookup Table feature</li> </ul>
1.3	2019-01-17	Modified the Width value for the maximum line rate on the VT-18K3.5X-H140
1.4	2020-09-18	<ul style="list-style-type: none"> <li>• Applied new CI</li> <li>• Updated mechanical dimensions for all VT CXP cameras</li> <li>• Added the maximum line rates based on the 10-bit and 12-bit Pixel Formats</li> </ul>
1.5	2021-01-21	<ul style="list-style-type: none"> <li>• Revised the model name</li> <li>• Added the following models: <ul style="list-style-type: none"> <li>▫ VT-6K10X-E170A-32</li> <li>▫ VT-9K7X-E120A-32</li> <li>▫ VT-9K7X-E250A-32</li> <li>▫ VT-12K5X-E100A-64</li> <li>▫ VT-12K5X-E200A-64</li> <li>▫ VT-16K5X-E140A-64</li> <li>▫ VT-18K3.5X-E80A-64</li> <li>▫ VT-18K3.5X-E140A-64</li> <li>▫ VT-23K3.5X-E100A-64</li> </ul> </li> <li>• Revised camera mechanical dimensions</li> </ul>

Version	Date	Description
1.6	2021-05-12	Corrected the orientation of the 4-pin connector in the user manual
	2021-09-24	Deleted the "Exposure Control" text in the "Main Features"
1.7	2021-09-30	Added how-to make the necessary settings to use the "Multi-Link" function
1.8	2022-05-27	Revised the mechanical dimension
	2022-06-07	Modified an error in the description of the "Scan Direction" section
		Added information on the "TDI Stages" section for VT-6K10X-H170
2022-11-24	Added information on UKCA certification	

# Contents

<b>1</b>	<b>Precautions</b> .....	<b>7</b>
<b>2</b>	<b>Warranty</b> .....	<b>9</b>
<b>3</b>	<b>Compliance &amp; Certifications</b> .....	<b>9</b>
3.1	FCC Compliance.....	9
3.2	CE.....	9
3.3	UKCA.....	9
3.4	KC.....	9
<b>4</b>	<b>Package Components</b> .....	<b>10</b>
<b>5</b>	<b>Product Specifications</b> .....	<b>12</b>
5.1	Overview.....	12
5.2	Specifications.....	13
5.3	Camera Block Diagram.....	25
5.4	Spectral Response.....	27
5.5	Mechanical Specification.....	28
5.5.1	Camera Mounting and Heat Dissipation.....	31
<b>6</b>	<b>Connecting the Camera</b> .....	<b>32</b>
6.1	Precaution to Connect the CXP Cables.....	33
6.2	Precaution to Center the Imaging Sensor.....	33
6.3	Installing Vieworks Imaging Solution.....	33
<b>7</b>	<b>Camera Interface</b> .....	<b>34</b>
7.1	General Description.....	34
7.2	CoaXPress Connector.....	35
7.2.1	CoaXPress BNC Connector (75 $\Omega$ BNC Receptacle).....	35
7.2.2	CoaXPress DIN Connector (75 $\Omega$ 1.0/2.3 DIN Receptacle).....	35
7.3	Power Input Receptacle.....	37
7.4	Control I/O Receptacle.....	38
7.5	Trigger / Direction Input Circuit.....	39
7.6	Strobe Output Circuit.....	39
<b>8</b>	<b>Acquisition Control</b> .....	<b>40</b>
8.1	Acquisition Start/Stop Commands and Acquisition Mode.....	40
8.2	Line Start Trigger.....	41
8.2.1	Trigger Mode.....	41
8.2.2	Using an External/CoaXPress Trigger Signal.....	44
8.2.3	Trigger Rescaler Mode.....	45

8.2.4	Trigger Statistics .....	46
8.3	Maximum Allowed Line Rate .....	47
<b>9</b>	<b>Camera Features .....</b>	<b>49</b>
9.1	Operation Mode .....	49
9.2	TDI Stages .....	50
9.3	Scan Direction .....	52
9.4	Region of Interest .....	53
9.4.1	Setting the ROI .....	53
9.5	Binning .....	54
9.6	Pixel Format .....	55
9.7	Gain and Black Level .....	56
9.8	LUT .....	57
9.9	Dark Signal Non-uniformity Correction .....	59
9.9.1	Generating and Saving User DSNU Correction Values .....	60
9.10	Photo Response Non-uniformity Correction .....	62
9.10.1	Generating and Saving User PRNU Correction Values .....	63
9.11	Reverse X .....	64
9.12	CXP Link Configuration .....	65
9.13	CXP Multi-Link Configuration (M72/M95 based VT Series Only) .....	66
9.14	Strobe Mode .....	67
9.15	Device User ID .....	68
9.16	Device Reset .....	68
9.17	Temperature Monitor .....	69
9.18	Status LED .....	69
9.19	Test Pattern .....	70
9.20	User Set Control .....	72
9.20.1	Factory Default Setting Values .....	73
9.21	Field Upgrade .....	73
<b>10</b>	<b>Troubleshooting .....</b>	<b>74</b>
<b>Appendix A</b>	<b>Field Upgrade .....</b>	<b>75</b>
A.1	MCU .....	75
A.2	FPGA .....	77
A.3	XML .....	78
<b>Appendix B</b>	<b>LUT Download .....</b>	<b>79</b>
B.1	Gamma Graph Download .....	79
B.2	CSV File Download .....	81

**Appendix C Correction Control .....83**

C.1 Adjusting and Saving Additional DSNU Correction Value ..... 84

C.2 Adjusting and Saving Additional PRNU Correction Value ..... 85

# 1 Precautions

## General



- Do not drop, disassemble, repair or alter the device. Doing so may damage the camera electronics and cause an electric shock.
- Do not let children touch the device without supervision.
- Stop using the device and contact the nearest dealer or manufacturer for technical assistance if liquid such as water, drinks or chemicals gets into the device.
- Do not touch the device with wet hands. Doing so may cause an electric shock.
- Make sure that the temperature of the camera does not exceed the temperature range specified in [5.2 Specifications](#). Otherwise the device may be damaged by extreme temperatures.

## Installation and Maintenance



- Do not install in dusty or dirty areas – or near an air conditioner or heater to reduce the risk of damage to the device.
- Avoid installing and operating in an extreme environment where vibration, heat, humidity, dust, strong magnetic fields, explosive/corrosive mists or gases are present.
- Do not apply excessive vibration and shock to the device. This may damage the device.
- Avoid direct exposure to a high intensity light source. This may damage the imaging sensor.
- Do not install the device under unstable lighting conditions. Severe lighting change will affect the quality of the image produced by the device.
- Do not use solvents or thinners to clean the surface of the device. This can damage the surface finish.

## Power Supply



- Applying incorrect power can damage the camera. If the voltage applied to the camera is greater or less than the camera's nominal voltage, the camera may be damaged or operate erratically. Please refer to [5.2 Specifications](#) for the camera's nominal voltage.
  - ※ Vieworks Co., Ltd. does NOT provide power supplies with the devices.
- Make sure the power is turned off before connecting the power cord to the camera. Otherwise, damage to the camera may result.

## Cleaning the Sensor Surface

Avoid cleaning the surface of the camera's sensor if possible. If you have dust or foreign matter on the sensor surface, use a soft lint free cotton bud dampened with a small quantity of high quality lens cleaner. Because electrostatic discharge (ESD) can damage the sensor, you must use a cloth (e.g. cotton) that will not generate static during cleaning.



### **Avoid dust or foreign matter on the sensor surface.**

The camera is shipped with a protective plastic seal on the camera front. To prevent collecting dust or foreign matter on the camera sensor, make sure that you always put the protective seal in place when there is no lens mounted on the camera. In addition, make sure to always point the camera downward when there is no protective seal on the camera front or no lens mounted.

## Procedures for Cleaning the Sensor

If you have dust or foreign matter on the sensor surface, follow the procedures below to wipe off.

1. Remove a contaminant by using an ionizing air gun.  
If this step does not remove the contaminant, proceed to the next step.
2. Clean the contaminant on the sensor using one drop of lens cleaner on a non-fluffy cotton bud.
3. Wipe the cotton bud gently in only one direction (either left to right or right to left). Avoid wiping back and forth with the same cotton bud in order to ensure that the contaminants are removed and not simply transferred to a new location on the sensor surface.
4. Mount a lens, set the lens at a smaller aperture (e.g. F8), and then acquire images under bright lighting conditions. Check the images on the monitor for dark spots or stripes caused by the contaminant. Repeat the steps above until there is no contaminant present.



If sensor is damaged due to electrostatic discharge or the sensor surface is scratched during cleaning, the warranty is void.



## 2 Warranty

Do not open the housing of the camera. The warranty becomes void if the housing is opened.  
For information about the warranty, please contact your local dealer or factory representative.

## 3 Compliance & Certifications

### 3.1 FCC Compliance

This equipment has been tested and found to comply with the limits for a Class A digital device, pursuant to part 15 of the FCC Rules. These limits are designed to provide reasonable protection against harmful interference when the equipment is operated in a commercial environment. This equipment generates, uses, and can radiate radio frequency energy and, if not installed and used in accordance with the instruction manual, may cause harmful interference to radio communications. Operation of this equipment in a residential area is likely to cause harmful interference in which case the user will be required to correct the interference at his own expenses.

### 3.2 CE

EMC Directive 2014/30/EU

EN 55032:2012 (Class A), EN 55024:2010

Class A

### 3.3 UKCA



The UKCA marking is the product marking used for products being placed on the market in Great Britain (England, Scotland and Wales). The UKCA marking applies to most products previously subject to the CE marking.\* Therefore, this device is eligible for the UKCA marking.

\*Source: [Using the UKCA marking at GOV.UK](#)

### 3.4 KC

#### KCC Statement

Type	Description
Class A (Broadcasting Communication Device for Office Use)	This device obtained EMC registration for office use (Class A), and may be used in places other than home. Sellers and/or users need to take note of this.

## 4 Package Components

Package Components



VT-9K7X-E/H120 / 12K5X-E/H100 / 18K3.5X-E/H80 Camera with M72 0.75 mount

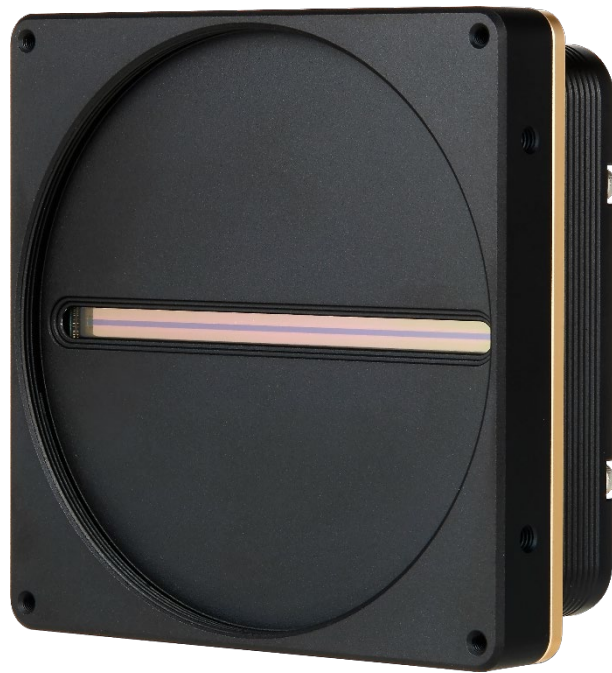


VT-6K10X-E/H170 / 9K7X-E/H250 / 12K5X-E/H200 / 18K3.5X-E/H140 Camera with M72 0.75 mount

Package Components



VT-3K7X-E/H250 / VT-4K5X-E/H200 / VT-6K3.5X-E/H160 Camera with M42 mount



VT-16K5X-E/H140 / VT-23K3.5X-E/H100 Camera with M95 mount

## 5 Product Specifications

### 5.1 Overview

VT series, Time Delay & Integration (TDI) line scan cameras, provides faster line rates and higher sensitivity than existing line scan cameras. Hybrid imaging sensor technology based on a combination of CCD and CMOS circuits allows image captures with up to 128× higher sensitivity using the M72 mount based VT-9K7X camera. Even superior resolution and sensitivity, up to 256× greater sensitivity can be achieved using the M72 mount based VT-18K3.5X camera. The VT-3K7X, VT-4K5X and VT-6K3.5X cameras have a compact design supporting the M42 mount. The VT-3K7X camera features up to 250 kHz line rates and 128× greater sensitivity. The VT-16K5X camera supporting the M95 mount achieves a maximum line rate of up to 140 kHz with 256× higher sensitivity. Even higher resolution, up to 100 kHz line rate and 256× higher sensitivity can be achieved using the VT-23K3.5X camera.

Its new CoaXPress interface supports transmitting image data at up to 25 Gbps using a common coax cabling. Featured with high speed and high resolution, VT series is ideal for demanding applications such as flat panel display inspection, wafer inspection, printed circuit board inspection, and high-performance document scanning.

#### Main Features

- Hybrid TDI Line Scan
- Max. 23360 × 256 Pixel Resolution
- Bidirectional Operations with up to 256 TDI Stages
- Anti-blooming
- Trigger Rescaler and Strobe Output Control
- CoaXPress Interface up to 25 Gbps using 4 coax cables (4ch)
- Advanced PRNU and DSNU Correction
- Area Scan Mode for Camera Alignment

#### Applications

- Flat Panel Display Inspection
- Printed Circuit Board Inspection
- Wafer Inspection
- High Performance Document Scanning

## 5.2 Specifications

Technical specifications for VT CXP series are as follows:

Specification		VT-6K10X-E170A-32	VT-6K10X-H170A-128
Active Image(H × V)		6240 × 32	6240 × 128
Sensor Type		Hybrid TDI Line Scan	
Pixel Size		10.0 μm × 10.0 μm	
Interface		CoaXPress (CXP-6)	
Pixel Data Format		8 / 10 / 12 bit	
TDI Stage		32	32 / 64 / 96 / 128
TDI Direction		External Control Port or Programmable	
Trigger Synchronization		Free-Run, External Trigger Signal, CoaXPress Programmable Line Rate and Trigger Polarity	
Max. Line Rate	8 bit	172 kHz	
	10 bit	172 kHz	
	12 bit	140 kHz	
Min. Line Rate		1 kHz	
Throughput		1.07 Gpix/s	
Gamma Correction		User Defined LUT (Look Up Table)	
Black Level		-255 ~ 255 at 8 bits	
Gain Control		Analog Gain: 1×, 2×, 3×, 4× / Digital Gain: 1.0× ~ 8.0×	
External Trigger		External, 3.3 V – 5.0 V	
Power	Adapter	10 ~ 30 V DC	
	Dissipation	Typ. 10.0 W	
	PoCXP	24 V DC, Minimum of two PoCXP cables required	
Environmental		Ambient Operating: 0°C ~ 40°C (Housing: 10°C ~ 50°C), Storage: -40°C ~ 70°C	
Mechanical		90 mm × 90 mm × 43 mm, 500 g	
API SDK		Vieworks Imaging Solution 7.X	
<b>Optical Interface</b>			
Lens Mount		M72 × 0.75 mm	
Sensor to Camera Front		10.20 mm (Optical Distance)	
Sensor Alignment			
Flatness		±25 μm	
x		±0.15 mm	
y		±0.15 mm	
z		±0.1 mm	

**Table 5.1 Specifications of the M72-mount VT CXP (VT-6K10X-E170A-32 / VT-6K10X-H170A-128)**

Specification		VT-9K7X-E250A-32	VT-9K7X-H250A-128
Active Image(H × V)		8912 × 32	8912 × 128
Sensor Type		Hybrid TDI Line Scan	
Pixel Size		7.0 μm × 7.0 μm	
Interface		CoaXPress (CXP-6)	
Pixel Data Format		8 / 10 / 12 bit	
TDI Stage		32	32 / 64 / 96 / 128
TDI Direction		External Control Port or Programmable	
Trigger Synchronization		Free-Run, External Trigger Signal, CoaXPress Programmable Line Rate and Trigger Polarity	
Max. Line Rate	8 bit	250 kHz	
	10 bit	215 kHz	
	12 bit	140 kHz	
Min. Line Rate		1 kHz	
Throughput		2.23 Gpix/s	
Gamma Correction		User Defined LUT (Look Up Table)	
Black Level		-255 ~ 255 at 8 bits	
Gain Control		Analog Gain: 1×, 2×, 3×, 4× / Digital Gain: 1.0× ~ 8.0×	
External Trigger		External, 3.3 V – 5.0 V	
Power	Adapter	10 ~ 30 V DC	
	Dissipation	Typ. 10.0 W	
	PoCXP	24 V DC, Minimum of two PoCXP cables required	
Environmental		Ambient Operating: 0°C ~ 40°C (Housing: 10°C ~ 50°C), Storage: -40°C ~ 70°C	
Mechanical		90 mm × 90 mm × 43 mm, 500 g	
API SDK		Vieworks Imaging Solution 7.X	
<b>Optical Interface</b>			
Lens Mount		M72 × 0.75 mm	
Sensor to Camera Front		10.20 mm (Optical Distance)	
Sensor Alignment			
Flatness		±25 μm	
x		±0.15 mm	
y		±0.15 mm	
z		±0.1 mm	

Table 5.2 Specifications of the M72-mount VT CXP (VT-9K7X-E250A-32 / VT-9K7X-H250A-128)

Specification		VT-12K5X-E200A-64	VT-12K5X-H200A-256
Active Image(H × V)		12480 × 64	12480 × 256
Sensor Type		Hybrid TDI Line Scan	
Pixel Size		5.0 μm × 5.0 μm	
Interface		CoaXPress (CXP-6)	
Pixel Data Format		8 / 10 / 12 bit	
TDI Stage		64	64 / 128 / 192 / 256
TDI Direction		External Control Port or Programmable	
Trigger Synchronization		Free-Run, External Trigger Signal, CoaXPress Programmable Line Rate and Trigger Polarity	
Max. Line Rate	8 bit	200 kHz	
	10 bit	160 kHz	
	12 bit	133 kHz	
Min. Line Rate		1 kHz	
Throughput		2.40 Gpix/s	
Gamma Correction		User Defined LUT (Look Up Table)	
Black Level		-255 ~ 255 at 8 bits	
Gain Control		Analog Gain: 1×, 2×, 3×, 4× / Digital Gain: 1.0× ~ 8.0×	
External Trigger		External, 3.3 V – 5.0 V	
Power	Adapter	10 ~ 30 V DC	
	Dissipation	Typ. 10.0 W	
	PoCXP	24 V DC, Minimum of two PoCXP cables required	
Environmental		Ambient Operating: 0°C ~ 40°C (Housing: 10°C ~ 50°C), Storage: -40°C ~ 70°C	
Mechanical		90 mm × 90 mm × 43 mm, 500 g	
API SDK		Vieworks Imaging Solution 7.X	
<b>Optical Interface</b>			
Lens Mount		M72 × 0.75 mm	
Sensor to Camera Front		10.20 mm (Optical Distance)	
Sensor Alignment			
Flatness		±25 μm	
x		±0.15 mm	
y		±0.15 mm	
z		±0.1 mm	

Table 5.3 Specifications of the M72-mount VT CXP (VT-12K5X-E200A-64 / VT-12K5X-H200A-256)

Specification		VT-18K3.5X-E140A-64	VT-18K3.5X-H140A-256
Active Image(H × V)		17824 × 64	17824 × 256
Sensor Type		Hybrid TDI Line Scan	
Pixel Size		3.5 μm × 3.5 μm	
Interface		CoaXPress (CXP-6)	
Pixel Data Format		8 / 10 / 12 bit	
TDI Stage		64	64 / 128 / 192 / 256
TDI Direction		External Control Port or Programmable	
Trigger Synchronization		Free-Run, External Trigger Signal, CoaXPress Programmable Line Rate and Trigger Polarity	
Max. Line Rate	8 bit	140 kHz	
	10 bit	112 kHz	
	12 bit	93 kHz	
Min. Line Rate		1 kHz	
Throughput		2.42 Gpix/s	
Gamma Correction		User Defined LUT (Look Up Table)	
Black Level		-255 ~ 255 at 8 bits	
Gain Control		Analog Gain: 1×, 2×, 3×, 4× / Digital Gain: 1.0× ~ 8.0×	
External Trigger		External, 3.3 V – 5.0 V	
Power	Adapter	10 ~ 30 V DC	
	Dissipation	Typ. 12.0 W	
	PoCXP	24 V DC, Minimum of two PoCXP cables required	
Environmental		Ambient Operating: 0°C ~ 40°C (Housing: 10°C ~ 50°C), Storage: -40°C ~ 70°C	
Mechanical		90 mm × 90 mm × 43 mm, 500 g	
API SDK		Vieworks Imaging Solution 7.X	
<b>Optical Interface</b>			
Lens Mount		M72 × 0.75 mm	
Sensor to Camera Front		10.20 mm (Optical Distance)	
Sensor Alignment			
Flatness		±25 μm	
x		±0.15 mm	
y		±0.15 mm	
z		±0.1 mm	

Table 5.4 Specifications of the M72-mount VT CXP (VT-18K3.5X-E140A-64 / VT-18K3.5X-H140A-256)



Specification		VT-9K7X-E120A-32	VT-9K7X-H120A-128
Active Image(H × V)		8912 × 32	8912 × 128
Sensor Type		Hybrid TDI Line Scan	
Pixel Size		7.0 μm × 7.0 μm	
Interface		CoaXPress (CXP-6)	
Pixel Data Format		8 / 10 / 12 bit	
TDI Stage		32	32 / 64 / 96 / 128
TDI Direction		External Control Port or Programmable	
Trigger Synchronization		Free-Run, External Trigger Signal, CoaXPress Programmable Line Rate and Trigger Polarity	
Max. Line Rate	8 bit	125 kHz	
	10 bit	125 kHz	
	12 bit	125 kHz	
Min. Line Rate		1 kHz	
Throughput		1.11 Gpix/s	
Gamma Correction		User Defined LUT (Look Up Table)	
Black Level		-255 ~ 255 at 8 bits	
Gain Control		Analog Gain: 1×, 2×, 3×, 4× / Digital Gain: 1.0× ~ 8.0×	
External Trigger		External, 3.3 V – 5.0 V	
Power	Adapter	10 ~ 30 V DC	
	Dissipation	Typ. 10.0 W	
	PoCXP	24 V DC, Minimum of two PoCXP cables required	
Environmental		Ambient Operating: 0°C ~ 40°C (Housing: 10°C ~ 50°C), Storage: -40°C ~ 70°C	
Mechanical / Weight		90 mm × 90 mm × 38 mm, 500 g	
API SDK		Vieworks Imaging Solution 7.X	
<b>Optical Interface</b>			
Lens Mount		M72 × 0.75 mm	
Sensor to Camera Front		10.20 mm (Optical Distance)	
Sensor Alignment			
Flatness	±25 μm		
x	±0.15 mm		
y	±0.15 mm		
z	±0.1 mm		

**Table 5.5 Specifications of the M72-mount VT CXP (VT-9K7X-E120A-32 / VT-9K7X-H120A-128)**

Specification		VT-12K5X-E100A-64	VT-12K5X-H100A-256
Active Image(H × V)		12480 × 64	12480 × 256
Sensor Type		Hybrid TDI Line Scan	
Pixel Size		5.0 μm × 5.0 μm	
Interface		CoaXPress (CXP-6)	
Pixel Data Format		8 / 10 / 12 bit	
TDI Stage		64	64 / 128 / 192 / 256
TDI Direction		External Control Port or Programmable	
Trigger Synchronization		Free-Run, External Trigger Signal, CoaXPress Programmable Line Rate and Trigger Polarity	
Max. Line Rate	8 bit	100 kHz	
	10 bit	100 kHz	
	12 bit	100 kHz	
Min. Line Rate		1 kHz	
Throughput		1.25 Gpix/s	
Gamma Correction		User Defined LUT (Look Up Table)	
Black Level		-255 ~ 255 at 8 bits	
Gain Control		Analog Gain: 1×, 2×, 3×, 4× / Digital Gain: 1.0× ~ 8.0×	
External Trigger		External, 3.3 V – 5.0 V	
Power	Adapter	10 ~ 30 V DC	
	Dissipation	Typ. 10.0 W	
	PoCXP	24 V DC, Minimum of two PoCXP cables required	
Environmental		Ambient Operating: 0°C ~ 40°C (Housing: 10°C ~ 50°C), Storage: -40°C ~ 70°C	
Mechanical / Weight		90 mm × 90 mm × 38 mm, 500 g	
API SDK		Vieworks Imaging Solution 7.X	
<b>Optical Interface</b>			
Lens Mount		M72 × 0.75 mm	
Sensor to Camera Front		10.20 mm (Optical Distance)	
Sensor Alignment			
Flatness	±25 μm		
x	±0.15 mm		
y	±0.15 mm		
z	±0.1 mm		

**Table 5.6 Specifications of the M72-mount VT CXP (VT-12K5X-E100A-64 / VT-12K5X-H100A-256)**

Specification		VT-18K3.5X-E80A-64	VT-18K3.5X-H80A-256
Active Image(H × V)		17824 × 64	17824 × 256
Sensor Type		Hybrid TDI Line Scan	
Pixel Size		3.5 μm × 3.5 μm	
Interface		CoaXPress (CXP-6)	
Pixel Data Format		8 / 10 / 12 bit	
TDI Stage		64	64 / 128 / 192 / 256
TDI Direction		External Control Port or Programmable	
Trigger Synchronization		Free-Run, External Trigger Signal, CoaXPress Programmable Line Rate and Trigger Polarity	
Max. Line Rate	8 bit	80 kHz	
	10 bit	80 kHz	
	12 bit	80 kHz	
Min. Line Rate		1 kHz	
Throughput		1.43 Gpix/s	
Gamma Correction		User Defined LUT (Look Up Table)	
Black Level		-255 ~ 255 at 8 bits	
Gain Control		Analog Gain: 1×, 2×, 3×, 4× / Digital Gain: 1.0× ~ 8.0×	
External Trigger		External, 3.3 V – 5.0 V	
Power	Adapter	10 ~ 30 V DC	
	Dissipation	Typ. 12.0 W	
	PoCXP	24 V DC, Minimum of two PoCXP cables required	
Environmental		Ambient Operating: 0°C ~ 40°C (Housing: 10°C ~ 50°C), Storage: -40°C ~ 70°C	
Mechanical / Weight		90 mm × 90 mm × 38 mm, 500 g	
API SDK		Vieworks Imaging Solution 7.X	
<b>Optical Interface</b>			
Lens Mount		M72 × 0.75 mm	
Sensor to Camera Front		10.20 mm (Optical Distance)	
Sensor Alignment			
Flatness	±25 μm		
x	±0.15 mm		
y	±0.15 mm		
z	±0.1 mm		

**Table 5.7 Specifications of the M72-mount VT CXP (VT-18K3.5X-E80A-64 / VT-18K3.5X-H80A-256)**

Specification		VT-3K7X-E250A-32	VT-3K7X-H250A-128
Active Image(H × V)		3200×32	3200×128
Sensor Type		Hybrid TDI Line Scan	
Pixel Size		7.0 μm × 7.0 μm	
Interface		CoaXPress (CXP-6)	
Pixel Data Format		8 / 10 / 12 bit	
TDI Stage		32	32 / 64 / 96 / 128
TDI Direction		External Control Port or Programmable	
Trigger Synchronization		Free-Run, External Trigger Signal, CoaXPress Programmable Line Rate and Trigger Polarity	
Max. Line Rate	8 bit	250 kHz	
	10 bit	250 kHz	
	12 bit	140 kHz	
Min. Line Rate		1 kHz	
Throughput		0.80 Gpix/s (CXP 2CH)	
Gamma Correction		User Defined LUT (Look Up Table)	
Black Level		-255 ~ 255 at 8 bits	
Gain Control		Analog Gain: 1×, 2×, 3×, 4× / Digital Gain: 1.0× ~ 8.0×	
External Trigger		External, 3.3 V – 5.0 V	
Power	Adapter	10 ~ 30 V DC	
	Dissipation	Typ. 3.5 W	
	PoCXP	24 V DC, Minimum of one PoCXP cables required	
Environmental		Ambient Operating: 0°C ~ 50°C (Housing: 10°C ~ 50°C), Storage: -40°C ~ 70°C	
Mechanical / Weight		60 mm × 60 mm × 36 mm, 223 g	
API SDK		Vieworks Imaging Solution 7.X	
Optical Interface			
Lens Mount		M42 × 1 mm	
Sensor to Camera Front		10.10 mm (Optical Distance)	
Sensor Alignment			
Flatness	±25 μm		
x	±0.15 mm		
y	±0.15 mm		
z	±0.1 mm		

Table 5.8 Specifications of the M42-mount VT CXP (VT-3K7X-E250A-32 / VT-3K7X-H250A-128)

Specification		VT-4K5X-E200A-64	VT-4K5X-H200A-256
Active Image(H × V)		4640×64	4640×256
Sensor Type		Hybrid TDI Line Scan	
Pixel Size		5.0 μm × 5.0 μm	
Interface		CoaXPress (CXP-6)	
Pixel Data Format		8 / 10 / 12 bit	
TDI Stage		64	64 / 128 / 192 / 256
TDI Direction		External Control Port or Programmable	
Trigger Synchronization		Free-Run, External Trigger Signal, CoaXPress Programmable Line Rate and Trigger Polarity	
Max. Line Rate	8 bit	200 kHz	
	10 bit	200 kHz	
	12 bit	140 kHz	
Min. Line Rate		1 kHz	
Throughput		0.93 Gpix/s (CXP 2CH)	
Gamma Correction		User Defined LUT (Look Up Table)	
Black Level		-255 ~ 255 at 8 bits	
Gain Control		Analog Gain: 1×, 2×, 3×, 4× / Digital Gain: 1.0× ~ 8.0×	
External Trigger		External, 3.3 V – 5.0 V	
Power	Adapter	10 ~ 30 V DC	
	Dissipation	Typ. 4.0 W	
	PoCXP	24 V DC, Minimum of one PoCXP cables required	
Environmental		Ambient Operating: 0°C ~ 50°C (Housing: 10°C ~ 50°C), Storage: -40°C ~ 70°C	
Mechanical / Weight		60 mm × 60 mm × 36 mm, 223 g	
API SDK		Vieworks Imaging Solution 7.X	
Optical Interface			
Lens Mount		M42 × 1 mm	
Sensor to Camera Front		10.10 mm (Optical Distance)	
Sensor Alignment			
Flatness		±25 μm	
x		±0.15 mm	
y		±0.15 mm	
z		±0.1 mm	

Table 5.9 Specifications of the M42-mount VT CXP (VT-4K5X-E200A-64 / VT-4K5X-H200A-256)

Specification		VT-6K3.5X-E160A-64	VT-6K3.5X-H160A-256
Active Image(H × V)		6560×64	6560×256
Sensor Type		Hybrid TDI Line Scan	
Pixel Size		3.5 μm × 3.5 μm	
Interface		CoaXPress (CXP-6)	
Pixel Data Format		8 / 10 / 12 bit	
TDI Stage		64	64 / 128 / 192 / 256
TDI Direction		External Control Port or Programmable	
Trigger Synchronization		Free-Run, External Trigger Signal, CoaXPress Programmable Line Rate and Trigger Polarity	
Max. Line Rate	8 bit	160 kHz	
	10 bit	146 kHz	
	12 bit	122 kHz	
Min. Line Rate		1 kHz	
Throughput		1.05 Gpix/s (CXP 2CH)	
Gamma Correction		User Defined LUT (Look Up Table)	
Black Level		-255 ~ 255 at 8 bits	
Gain Control		Analog Gain: 1×, 2×, 3×, 4× / Digital Gain: 1.0× ~ 8.0×	
External Trigger		External, 3.3 V – 5.0 V	
Power	Adapter	10 ~ 30 V DC	
	Dissipation	Typ. 4.5 W	
	PoCXP	24 V DC, Minimum of one PoCXP cables required	
Environmental		Ambient Operating: 0°C ~ 50°C (Housing: 10°C ~ 50°C), Storage: -40°C ~ 70°C	
Mechanical / Weight		60 mm × 60 mm × 36 mm, 223 g	
API SDK		Vieworks Imaging Solution 7.X	
Optical Interface			
Lens Mount		M42 × 1 mm	
Sensor to Camera Front		10.10 mm (Optical Distance)	
Sensor Alignment			
Flatness		±25 μm	
x		±0.15 mm	
y		±0.15 mm	
z		±0.1 mm	

**Table 5.10 Specifications of the M42-mount VT CXP (VT-6K3.5X-E160A-64 / VT-6K3.5X-H160A-256)**

Specification		VT-16K5X-E140A-64	VT-16K5X-H140A-256
Active Image(H × V)		16384 × 64	16384 × 256
Sensor Type		Hybrid TDI Line Scan	
Pixel Size		5.0 μm × 5.0 μm	
Interface		CoaXPress (CXP-6)	
Pixel Data Format		8 / 10 / 12 bit	
TDI Stage		64	64 / 128 / 192 / 256
TDI Direction		External Control Port or Programmable	
Trigger Synchronization		Free-Run, External Trigger Signal, CoaXPress Programmable Line Rate and Trigger Polarity	
Max. Line Rate	8 bit	140 kHz	
	10 bit	117 kHz	
	12 bit	97 kHz	
Min. Line Rate		1 kHz	
Throughput		2.29 Gpix/s	
Gamma Correction		User Defined LUT (Look Up Table)	
Black Level		-255 ~ 255 at 8 bits	
Gain Control		Analog Gain: 1×, 2×, 3×, 4× / Digital Gain: 1.0× ~ 8.0×	
External Trigger		External, 3.3 V – 5.0 V	
Power	Adapter	10 ~ 30 V DC	
	Dissipation	Typ. 12.0 W	
	PoCXP	24 V DC, Minimum of two PoCXP cables required	
Environmental		Ambient Operating: 0°C ~ 50°C (Housing: 10°C ~ 50°C), Storage: -40°C ~ 70°C	
Mechanical / Weight		100 mm × 100 mm × 43 mm, 608 g	
API SDK		Vieworks Imaging Solution 7.X	
<b>Optical Interface</b>			
Lens Mount		M95 × 1 mm	
Sensor to Camera Front		9.50 mm (Optical Distance)	
Sensor Alignment			
Flatness	±25 μm		
x	±0.15 mm		
y	±0.15 mm		
z	±0.1 mm		

**Table 5.11 Specifications of the M95-mount VT CXP (VT-16K5X-E140A-64 / VT-16K5X-H140A-256)**

Specification		VT-23K3.5X-E100A-64	VT-23K3.5X-H100A-256
Active Image(H × V)		23360 × 64	23360 × 256
Sensor Type		Hybrid TDI Line Scan	
Pixel Size		3.5 μm × 3.5 μm	
Interface		CoaXPress (CXP-6)	
Pixel Data Format		8 / 10 / 12 bit	
TDI Stage		64	64 / 128 / 192 / 256
TDI Direction		External Control Port or Programmable	
Trigger Synchronization		Free-Run, External Trigger Signal, CoaXPress Programmable Line Rate and Trigger Polarity	
Max. Line Rate	8 bit	100 kHz	
	10 bit	82 kHz	
	12 bit	68 kHz	
Min. Line Rate		1 kHz	
Throughput		2.34 Gpix/s (CXP 2CH)	
Gamma Correction		User Defined LUT (Look Up Table)	
Black Level		-255 ~ 255 at 8 bits	
Gain Control		Analog Gain: 1×, 2×, 3×, 4× / Digital Gain: 1.0× ~ 8.0×	
External Trigger		External, 3.3 V – 5.0 V	
Power	Adapter	10 ~ 30 V DC	
	Dissipation	Typ. 15.0 W	
	PoCXP	24 V DC, Minimum of two PoCXP cables required	
Environmental		Ambient Operating: 0°C ~ 50°C (Housing: 10°C ~ 50°C), Storage: -40°C ~ 70°C	
Mechanical / Weight		100 mm × 100 mm × 43 mm, 608 g	
API SDK		Vieworks Imaging Solution 7.X	
<b>Optical Interface</b>			
Lens Mount		M95 × 1 mm	
Sensor to Camera Front		9.50 mm (Optical Distance)	
Sensor Alignment			
Flatness	±25 μm		
x	±0.15 mm		
y	±0.15 mm		
z	±0.1 mm		

Table 5.12 Specifications of the M95-mount VT CXP (VT-23K3.5X-E100A-64 / VT-23K3.5X-H100A-256)



### 5.3 Camera Block Diagram

VT series consists of three printed circuit boards (PCB), and its block diagram is shown below.

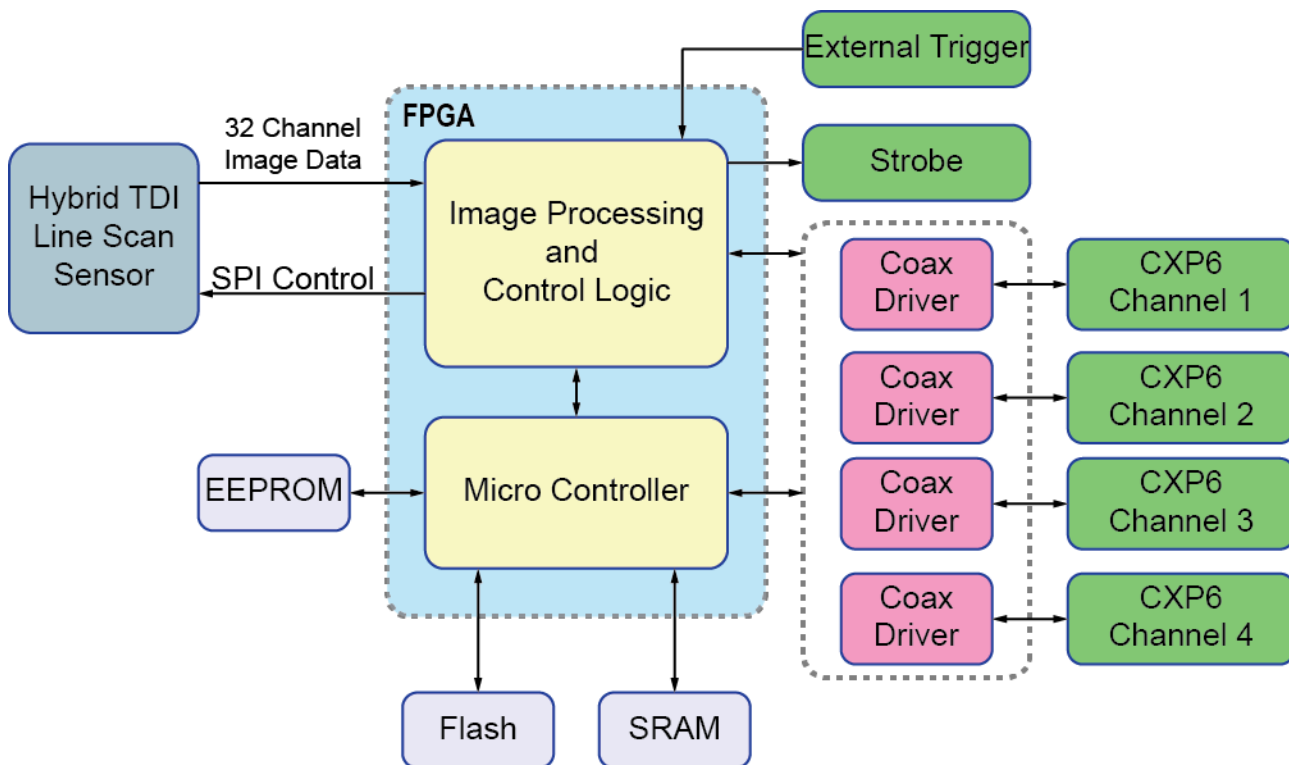


Figure 5.1 M72 and M95 mount based Camera Block Diagram

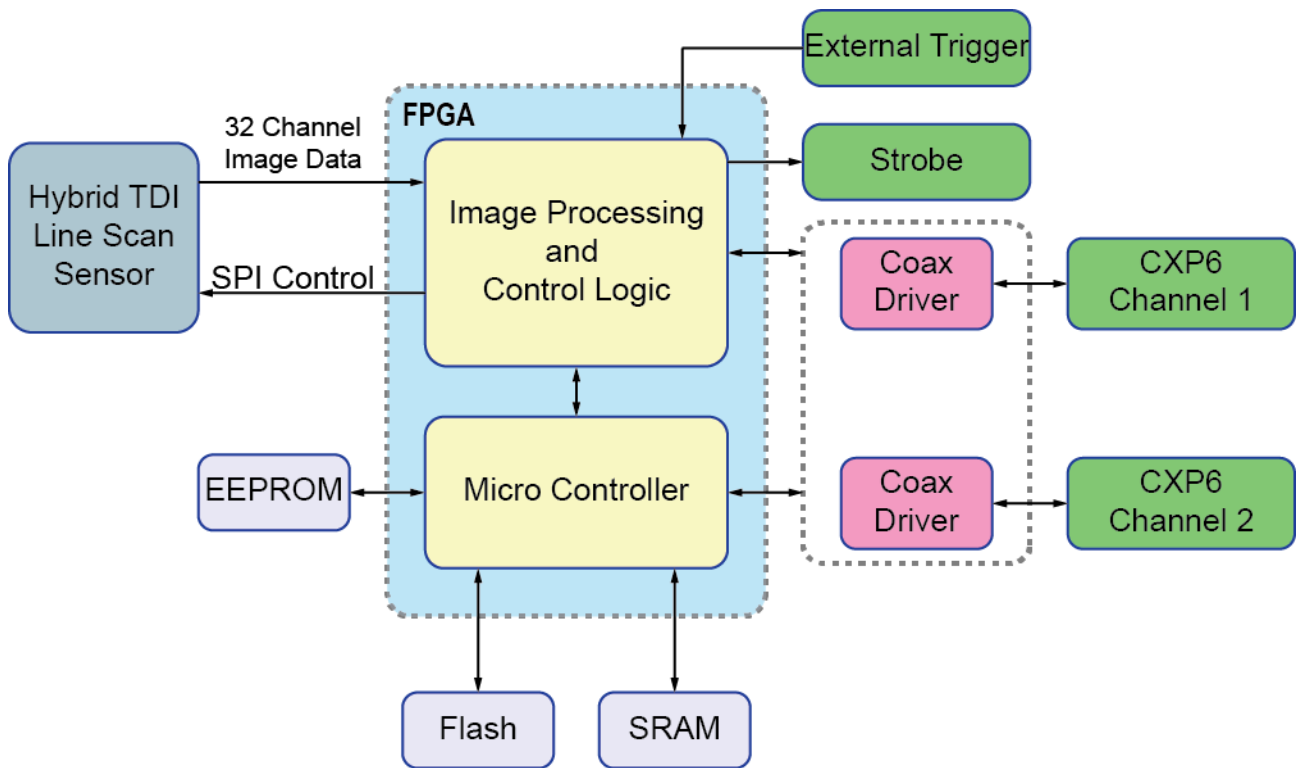
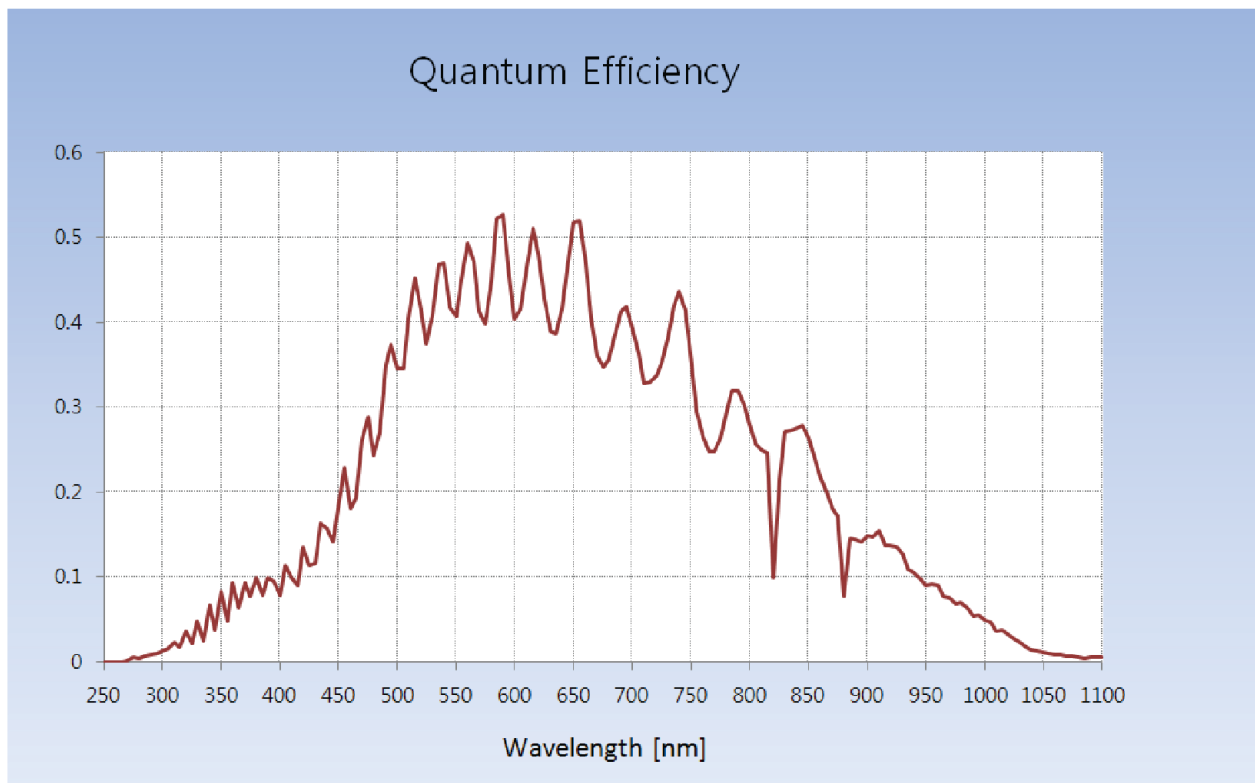


Figure 5.2 M42 mount based Camera Block Diagram

## 5.4 Spectral Response

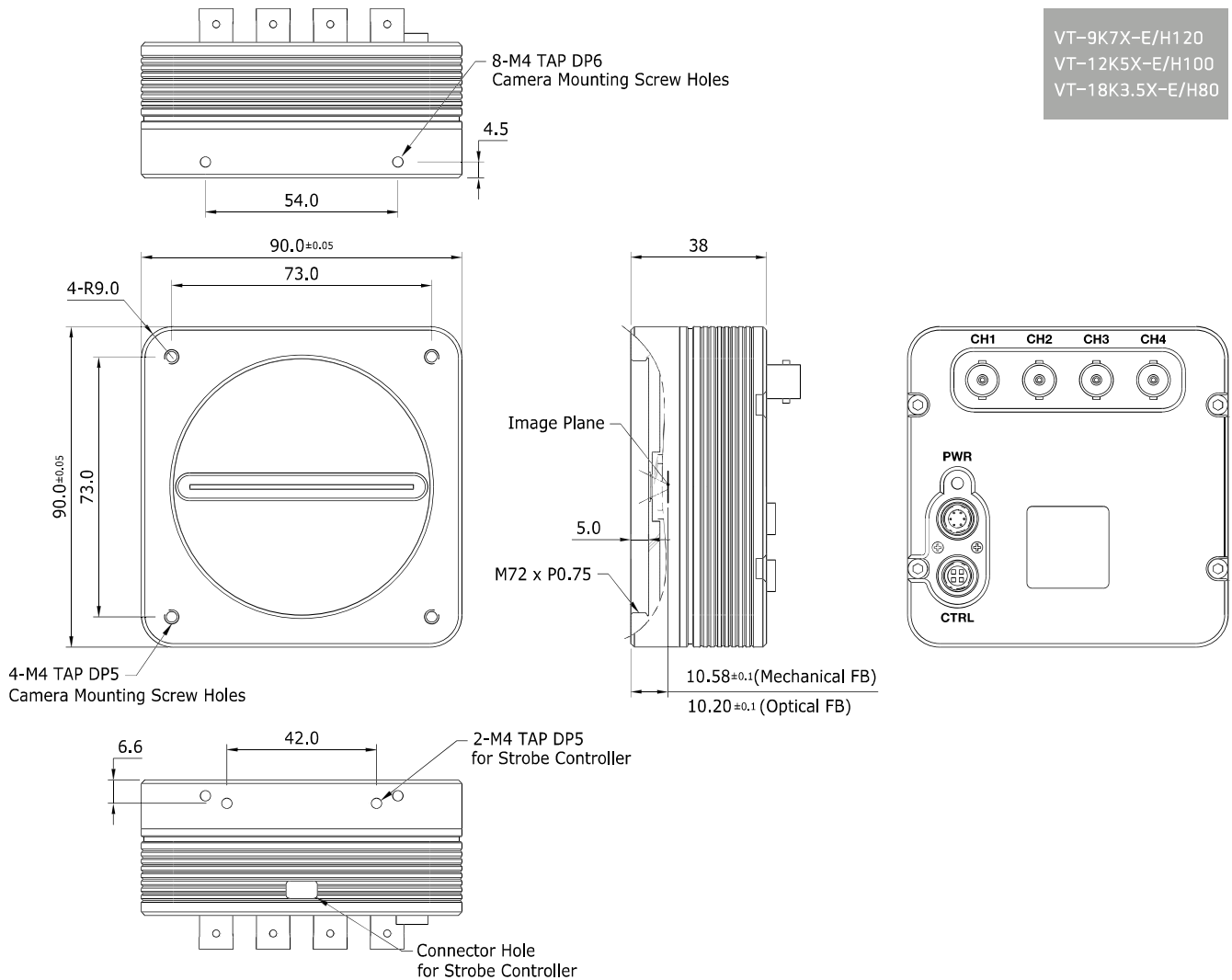
The following graph shows the spectral response for VT series.



**Figure 5.3 Quantum Efficiency (Monochrome)**

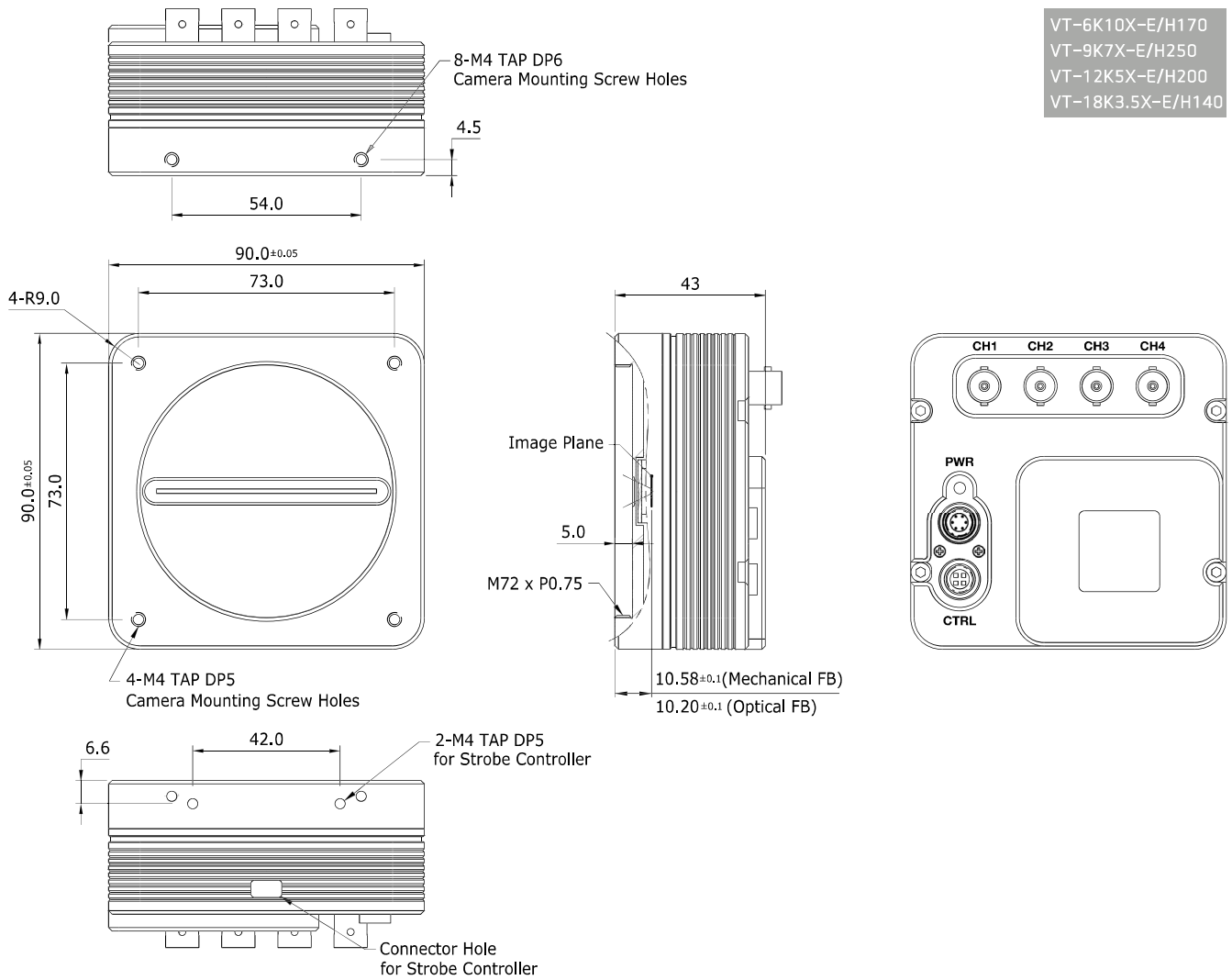
## 5.5 Mechanical Specification

The camera dimensions in millimeters are shown in the following figure.



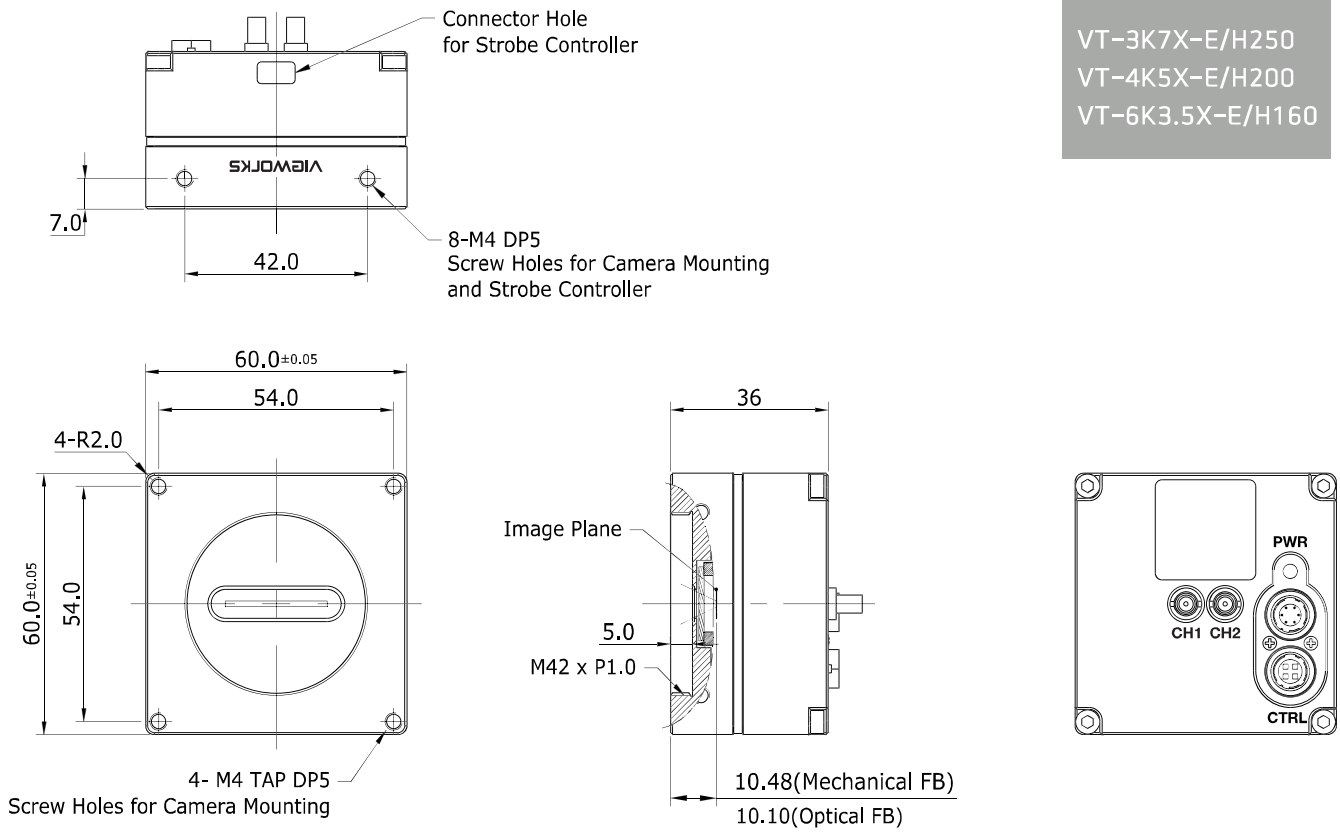
**Figure 5.4 M72 mount based VT CXP Series Mechanical Dimension (continuous)**

VT-6K10X-E/H170  
 VT-9K7X-E/H250  
 VT-12K5X-E/H200  
 VT-18K3.5X-E/H140

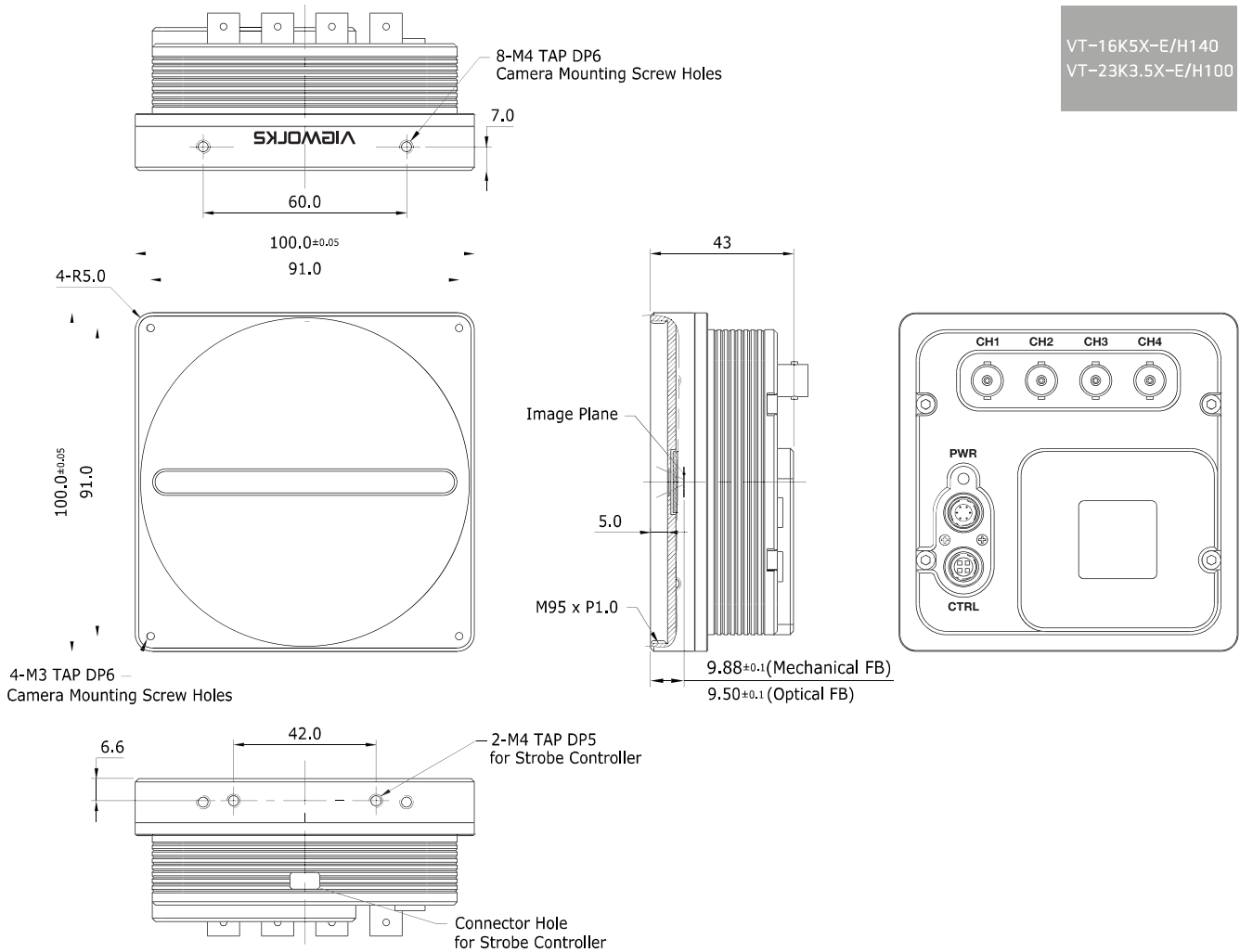


**Figure 5.5 M72 mount based VT CXP Series Mechanical Dimension**

VT-3K7X-E/H250  
 VT-4K5X-E/H200  
 VT-6K3.5X-E/H160



**Figure 5.6 M42 mount based VT CXP Series Mechanical Dimension**



**Figure 5.7 M95 mount based VT CXP Series Mechanical Dimension**

### 5.5.1 Camera Mounting and Heat Dissipation

You must mount the camera on a heat dissipation structure to maintain the temperature of the camera housing at 50°C or less. Given the low power consumption of the VT series camera, its housing temperature during operation will generally stay within the specified limits. However, overheating can occur if heat dissipation is restricted or if the camera is mounted on a severe environment. It is recommended to follow the general guidelines below when you mount the camera.

- In all cases, you should monitor the temperature of the camera housing and make sure that the temperature does not exceed 50°C. You can monitor the internal temperature of the camera by using the **Device Temperature** parameter.
- If your camera is mounted on a metal component in your system, this may provide sufficient heat dissipation.

## 6 Connecting the Camera

The following instructions assume that you have installed a CoaXPress Frame Grabber (hereinafter 'CXP Frame Grabber') in your computer including related software. Procedures below also assume that you may attempt to configure a link between a camera and CXP Frame Grabber by using four coax cables. For more detailed information, refer to your CXP Frame Grabber User Manual.

To connect the camera to your computer, follow the steps below:

1. Make sure that the power supply is not connected to the camera and your computer is turned off.
  - Go on to step 2 if you are using a power supply.
  - Go on to step 3 if you are using a Power over CoaXPress (PoCXP) Frame Grabber.
2. **If you are using a power supply:**
  - a. Plug one end of a coax cable into the CH1 of the CXP connector on the camera and the other end of the coax cable into the CH1 of the CXP Frame Grabber in your computer. Then, plug the other three coax cables into CH2, CH3 and CH4 of the camera and CXP Frame Grabber respectively.
  - b. Connect the plug of the power adapter to the 6-pin power input receptacle on the camera.
  - c. Plug the power adapter into a working electrical outlet.
3. **If you are using PoCXP Frame Grabber:**
  - a. Plug one end of a coax cable into the CH1 of the CXP connector on the camera and the other end of the coax cable into the CH1 of the CXP Frame Grabber in your computer. Then, plug the other three coax cables into CH2, CH3 and CH4 of the camera and CXP Frame Grabber respectively.
  - b. You must connect both CH1 and CH2 channels to power the camera via PoCXP.
4. Verify all the cable connections are secure.

### Precautions for using Power over CoaXPress



- **M72 and M95 mount based VT CXP Series**
  - To power a camera via PoCXP Frame Grabber, you must connect both CH1 and CH2 channels of the camera to their respective connectors on the CXP Frame Grabber.
- **M42 mount based VT CXP Series**
  - To power a camera via PoCXP Frame Grabber, you must connect the CH1 channel of the camera to its respective connector on the CXP Frame Grabber.



## 6.1 Precaution to Connect the CXP Cables

External or system vibrations may result in loosening or disengagement of the CXP cables from the CXP DIN connectors. Vieworks recommends that you make a connector locking bracket for your application or use a dedicated locking bracket (available from Vieworks, sold separately) for securing the cables to the CXP DIN connectors.

## 6.2 Precaution to Center the Imaging Sensor

- Users do not need to center the imaging sensor as it is adjusted as factory default settings.
- When you need to adjust the center of the imaging sensor, please contact your local dealer or the manufacturer for technical assistance.

## 6.3 Installing Vieworks Imaging Solution

You can download the Vieworks Imaging Solution at <http://vision.vieworks.com>. You should perform the software installation first and then the hardware installation.

## 7 Camera Interface

### 7.1 General Description

As shown in the figure below, 3 types of connectors and a status indicator LED are located on the back of the camera and have the functions as follows:

- ① CoaXPress connector: controls video data and the camera.
- ② Status LED: displays power status and operation mode.
- ③ 6 pin power input receptacle: supplies power to the camera (if PoCXP is not used).
- ④ 4 pin control receptacle: provides access to the camera's I/O lines.

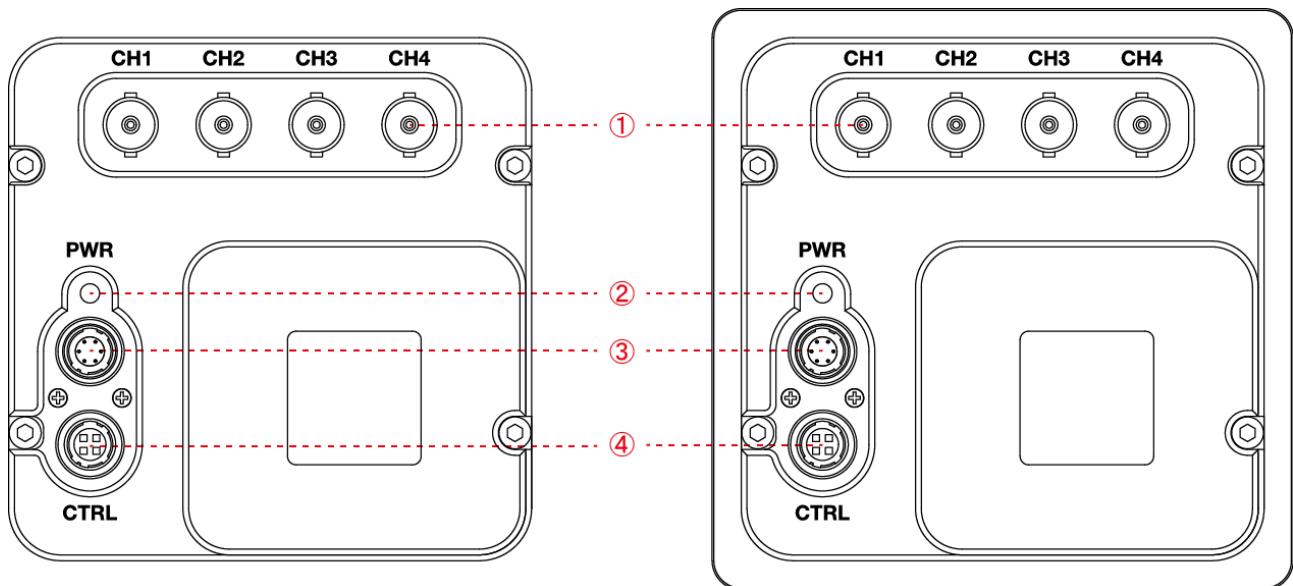


Figure 7.1 M72 mount (left) and M92 mount (right) based VT CXP Series Back Panel

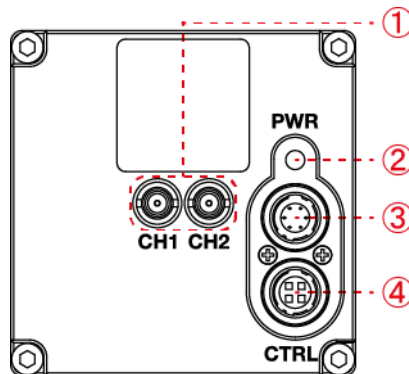


Figure 7.2 M42 mount based VT CXP Series Back Panel

## 7.2 CoaXPress Connector

CoaXPress protocol includes an automatic link detection mechanism (Plug and Play) to correctly detect the camera to the CXP Frame Grabber connection. The connection between the camera and CXP Frame Grabber uses a coax (also known as 'coaxial') cable and provides up to 6.25 Gbps bit rate per cable. The cameras can be powered over the coax cable if you are using a PoCXP enabled Frame Grabber.

### 7.2.1 CoaXPress BNC Connector (75 $\Omega$ BNC Receptacle)

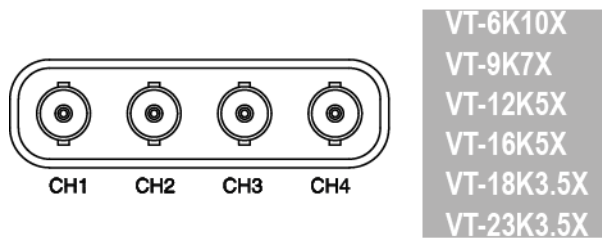


Figure 7.3 CoaXPress BNC Connectors

### 7.2.2 CoaXPress DIN Connector (75 $\Omega$ 1.0/2.3 DIN Receptacle)



Figure 7.4 CoaXPress DIN Connector

The CoaXPress connector on the VT CXP camera complies with the CoaXPress standard and the following table shows the channel assignments.

Channel	Max. Bit Rate per Coax	Type	PoCXP Compliant
CH1	6.25 Gbps	Master Connection	Yes
CH2	6.25 Gbps	Extension Connection	Yes
CH3	6.25 Gbps	Extension Connection	No
CH4	6.25 Gbps	Extension Connection	No

**Table 7.1 Channel Assignments for M72 and M95 mount based VT CXP Series CoaXPress Connector**

Channel	Max. Bit Rate per Coax	Type	PoCXP Compliant
CH1	6.25 Gbps	Master Connection	Yes
CH2	6.25 Gbps	Extension Connection	No

**Table 7.2 Channel Assignments for M42 mount based VT CXP Series CoaXPress Connector**



When you connect a camera to a CXP Frame Grabber using coax cables, make sure to connect the cables to their correct channels. If you connect the CH1 of the CXP connector on the camera to a channel other than CH1 of the CXP Frame Grabber, the camera may not transmit images properly or the communication between the computer and camera may fail.

### 7.3 Power Input Receptacle

The power input receptacle is a Hirose 6-pin connector (part # HR10A-7R-6PB). The pin assignments and configurations are as follows:

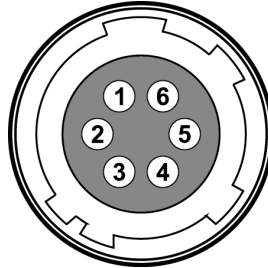


Figure 7.5 Pin Assignments for 6-pin Power Input Receptacle

Pin Number	Signal	Type	Description
1, 2, 3	DC Power +	Input	DC Power Input
4, 5, 6	DC Ground -	Input	DC Ground

Table 7.3 Pin Arrangements for Power Input Receptacle



- A recommended mating connector for the Hirose 6-pin connector is the Hirose 6-pin plug (part # HR10A-7P-6S) or the equivalent.
- It is recommended that you use the power adapter, which has at least 3 A current output at 10 ~ 30 V voltage output (You need to purchase a power adapter separately.).

#### Precaution for Power Input



- Make sure the power is turned off before connecting the power cord to the camera. Otherwise, damage to the camera may result.
- If the voltage applied to the camera is greater than specified in the specifications, damage to the camera may result.

## 7.4 Control I/O Receptacle

The control I/O receptacle is a Hirose 4-pin connector (part # HR10A-7R-4S) and consists of an external trigger signal input and strobe output ports. The pin assignments and configurations are as follows:

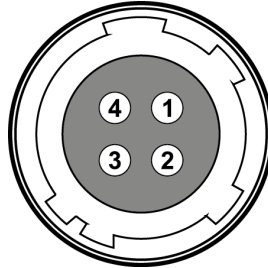


Figure 7.6 Pin Assignments for 4-pin Control I/O Receptacle

Pin Number	Signal	Type	Description
1	Trigger Input	Input	3.3 V ~ 5.0 V TTL input
2	Scan Direction Input	Input	3.3 V ~ 5.0 V TTL input
3	DC Ground	-	DC Ground
4	Strobe Out	Output	3.3 V TTL Output Output resistance: 47 $\Omega$

Table 7.4 Pin Arrangements for Control I/O Receptacle



A recommended mating connector for the Hirose 4-pin connector is the Hirose 4-pin plug (part # HR10A-7P-4P) or the equivalent.

## 7.5 Trigger / Direction Input Circuit

The following figure shows trigger signal and TDI direction input circuit of the 4-pin connector. Transmitted trigger and TDI direction signal is applied to the internal circuit through a CMOS buffer with a good noise margin. The minimum trigger width that can be recognized by the camera is 1  $\mu$ s. If transmitted trigger signal is less than 1  $\mu$ s, the camera will ignore the trigger signal. An external trigger and TDI direction circuit example is shown below.

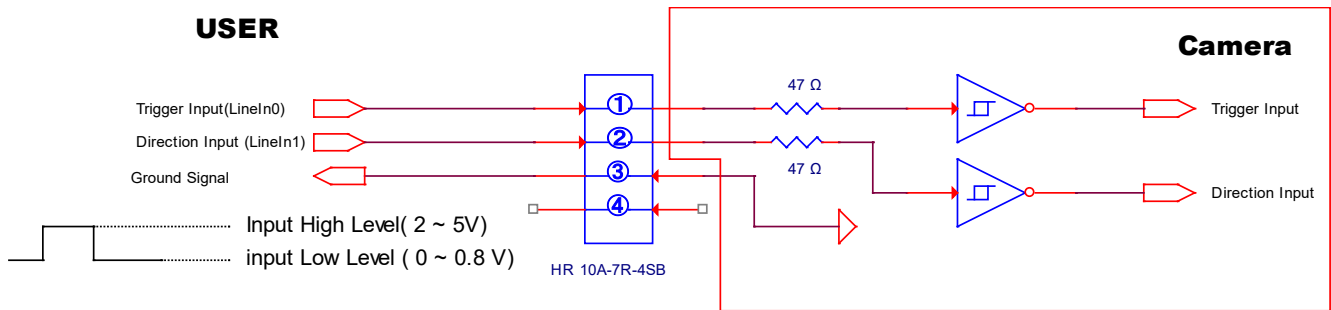


Figure 7.7 Trigger / Direction Input Schematic

## 7.6 Strobe Output Circuit

The strobe output signal comes out through a 3.3 V output level of Line Driver IC. A pulse width of the signal is synchronized with a Line Start trigger (shutter) signal of the camera (refer to [9.14 Strobe Mode](#)).

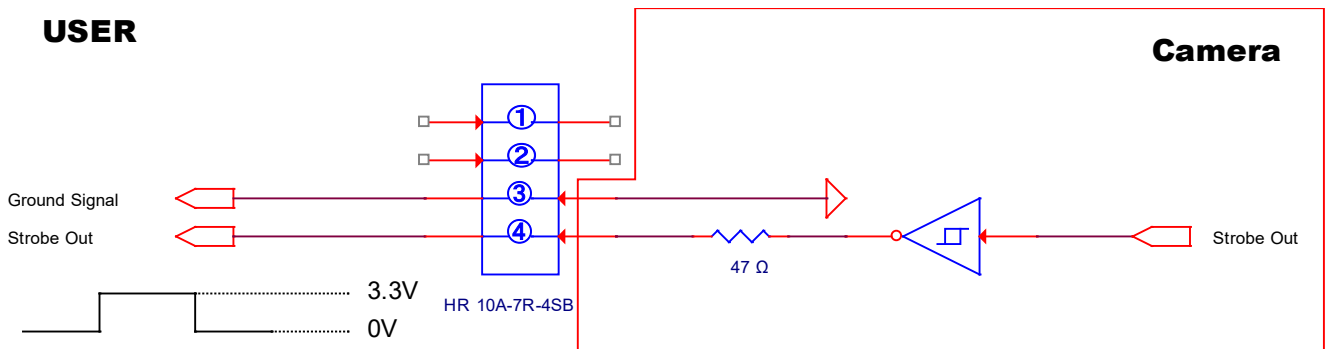


Figure 7.8 Strobe Output Schematic

## 8 Acquisition Control

This chapter provides detailed information about the following elements involved with the image acquisition.

- **Acquisition Start/Stop** commands and **Acquisition Mode** parameter
- Line Start trigger
- Line Rate control

### 8.1 Acquisition Start/Stop Commands and Acquisition Mode

The **Acquisition Start** command prepares the camera to acquire images. The camera cannot acquire images unless an **Acquisition Start** command has first been executed.

Executing an **Acquisition Stop** command terminates the camera's ability to acquire images.

A parameter called the **Acquisition Mode** has a direct bearing on how the **Acquisition Start** command operates. VT CXP cameras only support **Continuous** for the **Acquisition Mode** parameter.

The **Acquisition Start** command will remain in effect until you execute an **Acquisition Stop** command. Once an **Acquisition Stop** command has been executed, the camera will not be able to acquire images until a new **Acquisition Start** command is executed.



## 8.2 Line Start Trigger

The **Trigger Selector** parameter is used to select a type of trigger and only the **Line Start** trigger is available on the VT CXP camera. The Line Start trigger is used to begin line acquisition.

Line Start trigger signals can be generated within the camera or may be applied externally by setting the **Trigger Source** parameter to **LineIn0** or **CXPIn**. If a line start trigger signal is applied to the camera, the camera will begin to acquire images.

### 8.2.1 Trigger Mode

The main parameter associated with the line start trigger is the **Trigger Mode** parameter. The **Trigger Mode** parameter for the line start trigger has two available settings: **Off** and **On**.

#### 8.2.1.1 Trigger Mode = Off

When the **Trigger Mode** parameter is set to **Off**, the camera will generate all required line start trigger signals internally, and you do not need to apply line start trigger signals to the camera.

If the **Trigger Mode** parameter is set to **Off**, the camera will automatically begin generating line start trigger signals when it receives an **Acquisition Start** command. The camera will continue to generate line start trigger signals until it receives an **Acquisition Stop** command.

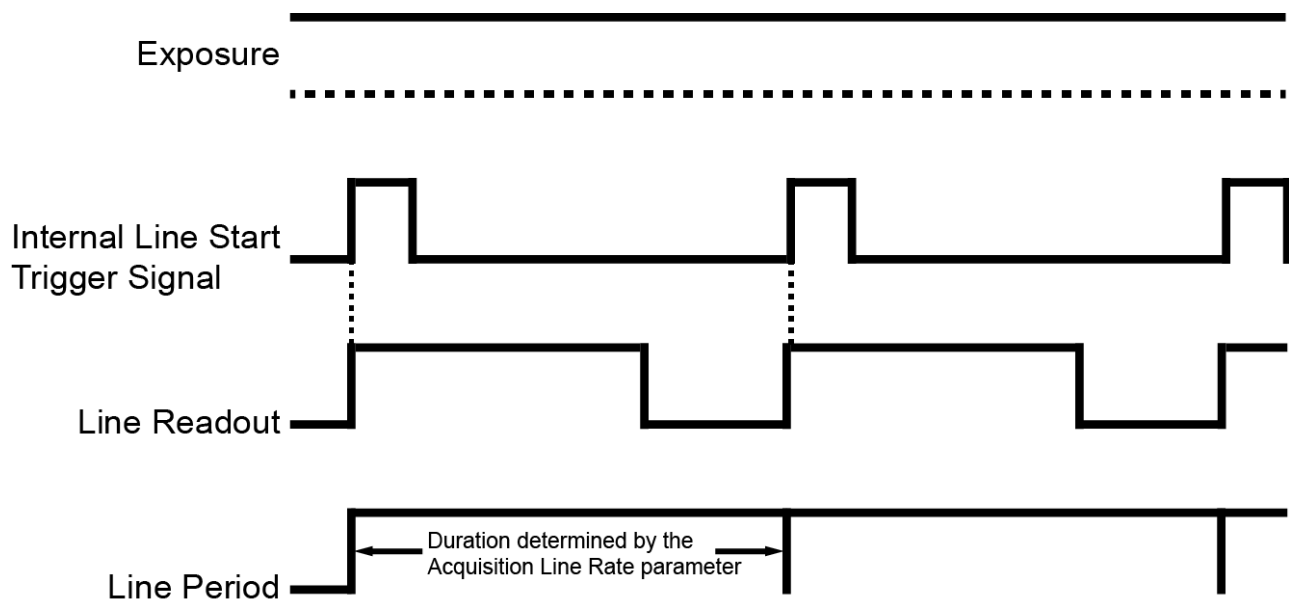


#### Free Run

When you set the **Trigger Mode** parameter to **Off**, the camera will generate all required trigger signals internally. When the camera is set this way, it will constantly acquire images without any need for triggering by the user. This use case is commonly known as “free run”.

The rate at which the line start trigger signals are generated may be determined by the camera's **Acquisition Line Rate** parameter.

- If the parameter is set to a value less than the maximum allowed line rate with the current camera settings, the camera will generate line start trigger signals at the rate specified by the parameter setting.
- If the parameter is set to a value greater than the maximum allowed line rate with the current camera settings, the camera will generate line start trigger signals at the maximum allowed line rate.



**Figure 8.1** Trigger Mode = Off

### 8.2.1.2 Trigger Mode = On

When the **Trigger Mode** parameter is set to **On**, you must apply a line start trigger signal to the camera each time you want to begin an image acquisition. The **Trigger Source** parameter specifies the source signal that will act as the line start trigger signal.

The available settings for the **Trigger Source** parameter are:

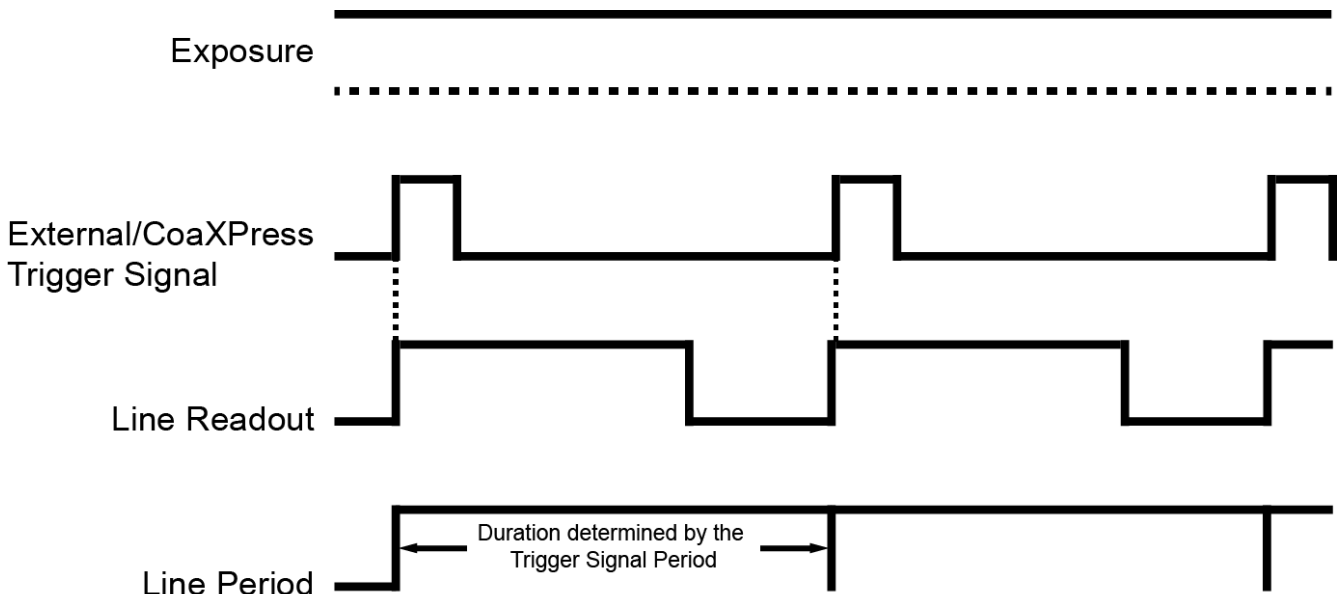
- **LineIn0:** You can apply a line start trigger signal to the camera by injecting an externally generated electrical signal (commonly referred to as a hardware or external trigger signal) into the Control I/O receptacle on the camera. Refer to [7.5 Trigger Input Circuit](#) for more information.
- **CXPIn:** You can apply a line start trigger signal via CH1 of the CXP Frame Grabber. For more information, refer to your CXP Frame Grabber User Manual.

If the **Trigger Source** parameter is set to **LineIn0** or **CXPIn**, you must also set the **Trigger Activation** parameter.

The available settings for the **Trigger Activation** parameter are:

- **Rising Edge:** Specifies that a rising edge of the electrical signal will act as the line start trigger.
- **Falling Edge:** Specifies that a falling edge of the electrical signal will act as the line start trigger.
- **Any Edge:** Specifies that both rising and falling edges of the electrical signal will act as the line start trigger.

When the **Trigger Mode** parameter is set to **On**, the camera's line rate can be controlled by manipulating the external trigger signal. At this point, it is important that you do not attempt to trigger images at a rate that is greater than the maximum allowed.



**Figure 8.2 Trigger Mode = On**

## 8.2.2 Using an External/CoaXPress Trigger Signal

If the **Trigger Mode** parameter is set to **On** and the **Trigger Source** parameter is set to **LineIn0** or **CXPIn**, you must apply an external or CoaXPress trigger signal to the camera to begin image acquisition.

To apply trigger signals via CH1 of the CXP Frame Grabber, you must set the **Trigger Source** parameter to **CXPIn**. At that point, each time a proper CoaXPress trigger signal is applied to the camera by using the APIs provided by a CXP Frame Grabber manufacturer, the line start trigger signal will be applied to the camera. For more information, refer to your CXP Frame Grabber User Manual.

To apply trigger signals via hardware (external), you must set the **Trigger Source** parameter to **LineIn0**. At that point, each time a proper electrical signal is applied to the camera, an occurrence of the line start trigger signal will be recognized by the camera.

A rising edge and/or a falling edge of the external or CoaXPress signal can be used to trigger image acquisition. The **Trigger Activation** parameter is used to select rising edge and/or falling edge triggering. When the camera is operating under control of an external or CoaXPress signal, the period of trigger signal will determine the rate at which the camera is acquiring images:

$$\text{Line Rate (Hz)} = \frac{1}{\text{External/CoaXPress signal period in seconds}}$$

For example, if you are operating a camera with an external trigger signal period of 20  $\mu\text{s}$  (0.00002 s):  
So in this case, the line rate is 50 kHz.

### 8.2.3 Trigger Rescaler Mode

In the **Trigger Rescaler Mode**, you can modulate the period of the external trigger signal as desired. For example, if you supply the external trigger signal into the camera's I/O receptacle using the conveyor's encoder, the number of output pulses per revolution of the encoder is fixed. In this situation, you can modulate the period of the trigger signal received from the camera in the following manner to match the pitch of the image in vertical direction.

$$\text{Line Rate (Hz)} = \text{External Trigger Line Rate} \times \text{Trigger Rescaler Rate}$$

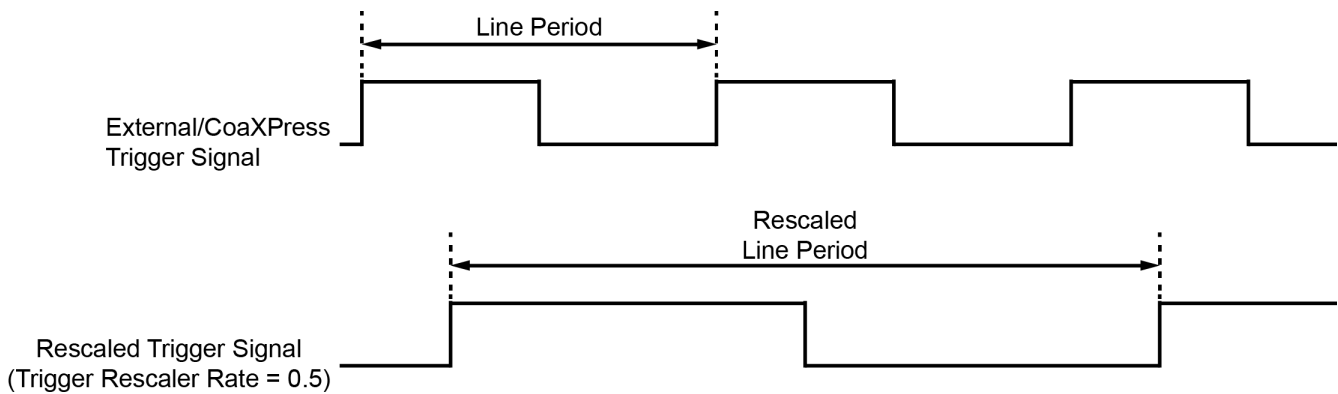


Figure 8.3 Trigger Rescaler Rate = 0.5

The XML parameters related to Trigger Rescaler Mode are as follows.

XML Parameters		Value	Description
AcquisitionControl	TriggerRescalerMode	Off	Disables Trigger Rescaler Mode.
		On	Enables Trigger Rescaler Mode.
	TriggerRescalerRate	0.010000 ~ 100.000000	Sets the trigger rescaler rate for converting trigger signals.
	TriggerRescalerFilter	Set the rescaler filter factor to decrease the jitter of the external trigger signals.	
		16	Set the rescaler filter factor to 16.
		32	Set the rescaler filter factor to 32.
		64	Set the rescaler filter factor to 64.
		128	Set the rescaler filter factor to 128.
256		Set the rescaler filter factor to 256.	
512	Set the rescaler filter factor to 512.		

Table 8.1 XML Parameters related to Trigger Rescaler Mode

## 8.2.4 Trigger Statistics

The Trigger Statistics feature allows you to determine the trigger signals applied to the camera and then converted by the Trigger Rescaler.

The XML parameters related to Trigger Statistics are as follows.

XML Parameters		Value	Description
TriggerStatistics	InputTriggerRate	-	Displays the rate at which the input trigger signals are applied to the camera in Hz.
	InputTriggerRateHighest	-	Displays the highest rate at which the input trigger signals are applied to the camera in Hz.
	InputTriggerJitter	-	Displays the jitter of the input trigger signals in %.
	InputTriggerDuration	-	Displays the pulse duration of the input trigger signals in $\mu s$ .
	RescaledTriggerRate	-	Displays the rate of the trigger signals converted by the Trigger Rescaler in Hz.
	RescaledTriggerJitter	-	Displays the jitter of the input trigger signals converted by the Trigger Rescaler in %.

**Table 8.2 XML Parameters related to Trigger Statistics**

## 8.3 Maximum Allowed Line Rate

In general, the maximum allowed acquisition line rate on the camera may be limited by the following factors:

- The maximum allowed bit rate per cable and the number of CXP Link Configuration

When the maximum allowed bit rate per cable is set to a high value (e.g., CXP5 supports up to 5.000 Gbps and CXP6 supports up to 6.250 Gbps), it will take less time to transfer acquired images from the camera to the CXP Frame Grabber in your computer.

When the camera is set for a CXP Link Configuration that uses more channels (e.g., CXP6\_X2 uses two channels and CXP6\_X4 uses four channels), it can typically transfer data out of the camera faster.

So if the camera is set for a high bit rate and a high number of channels, it will typically have a much higher maximum allowed line rate than when it is set for a low bit rate and a low number of channels.

The maximum allowed line rates of the M72 mount based VT CXP camera models are as follows:

CXP Link Configuration	VT-6K10X-E/H170	VT-9K7X-E/H250	VT-12K5X-E/H200	VT-18K3.5X-E/H140
CXP5 × 2	154 kHz	117 kHz	77 kHz (@ ROI 12480) 80 kHz (@ ROI 12000)	54 kHz (@ ROI 17824) 56 kHz (@ ROI 17120)
CXP6 × 2	172 kHz	125 kHz	96 kHz (@ ROI 12480) 100 kHz (@ ROI 12000)	67 kHz (@ ROI 17824) 70 kHz (@ ROI 17120)
CXP5 × 4	172 kHz	234 kHz	154 kHz (@ ROI 12480) 160 kHz (@ ROI 12000)	108 kHz (@ ROI 17824) 112 kHz (@ ROI 17120)
CXP6 × 4	172 kHz	250 kHz	192 kHz (@ ROI 12480) 200 kHz (@ ROI 12000)	134 kHz (@ ROI 17824) 140 kHz (@ ROI 17120)

**Table 8.3 Maximum Line Rates of the M72-mount based VT CXP Camera Models (continuous)**

CXP Link Configuration	VT-9K7X-E/H120	VT-12K5X-E/H100	VT-18K3.5X-E/H80
CXP5 × 2	108 kHz	77 kHz	54 kHz
CXP6 × 2	125 kHz	97 kHz	68 kHz
CXP5 × 4	125 kHz	100 kHz	80 kHz
CXP6 × 4	125 kHz	100 kHz	80 kHz

**Table 8.4 Maximum Line Rates of the M72-mount based VT CXP Camera Models**

The maximum allowed line rates of the M42 mount based VT CXP camera models are as follows:

CXP Link Configuration	VT-3K7X-E/H250	VT-4K5X-E/H200	VT-6K3.5X-E/H160
CXP5 × 1	141 kHz	100 kHz	72 kHz
CXP6 × 1	177 kHz	125 kHz	90 kHz
CXP5 × 2	250 kHz	200 kHz	143 kHz
CXP6 × 2	250 kHz	200 kHz	160 kHz

**Table 8.5 Maximum Line Rates of the M42-mount based VT CXP Camera Models**

The maximum allowed line rates of the M95 mount based VT CXP camera models are as follows:

CXP Link Configuration	VT-16K5X-E/H140	VT-23K3.5X-E/H100
CXP5 × 2	59 kHz	42 kHz
CXP6 × 2	74 kHz	52 kHz
CXP5 × 4	118 kHz	83 kHz
CXP6 × 4	140 kHz	100 kHz

**Table 8.6 Maximum Line Rates of the M95-mount based VT CXP Camera Models**



VT CXP camera also supports CXP 3 (3.125 Gbps).



## 9 Camera Features

### 9.1 Operation Mode

VT CXP cameras have two different operation modes: **Area** and **TDI** (Time Delay and Integration).

If the **Operation Mode** parameter is set to **Area**, the camera will operate as an area scan camera using two dimensional array of pixels. This mode is useful for aligning the camera to your target object.

If the **Operation Mode** parameter is set to **TDI**, the camera will operate as a high sensitivity line scan camera and provide up to  $256 \times$  higher sensitivity than existing line scan cameras.

The XML parameters related to Operation Mode are as follows.

XML Parameters		Value	Description
AcquisitionControl	OperationMode	TDI	Operates the camera in the TDI mode.
		Area	Operates the camera in the Area mode.

**Table 9.1 XML Parameters related to Operation Mode**

## 9.2 TDI Stages

In the **TDI** mode, the **TDI Stages** parameter is used to determine the number of integration stages used by the camera. For example, if the **TDI Stages** parameter is set to **256**, the camera will acquire images with  $256 \times$  higher sensitivity.

In the **Area** mode, the **TDI Stages** parameter is used to determine the height of the imaging sensor. For example, if the **Operation Mode** parameter is set to **Area** and the **TDI Stages** parameter is set to **256** on the VT-18K3.5X-H140A-256 camera, the camera will acquire  $17824 \times 256$  area images.

The XML parameters related to TDI Stages are as follows.

XML Parameters		Value	Description
ImageFormatControl	TDI Stages	32	Sets the number of TDI Stages to 32.
		64	Sets the number of TDI Stages to 64.
		96	Sets the number of TDI Stages to 96.
		128	Sets the number of TDI Stages to 128.

**Table 9.2 XML Parameters related to TDI Stages (VT-3K7X / VT-6K10X / VT-9K7X)**



VT-6K10X-H170 shows 64, 128, 192, 256 values to choose in the TDI Stages described the table above. However, each of those performs 32, 64, 96, 128 stages actually if chosen.

XML Parameters		Value	Description
ImageFormatControl	TDI Stages	64	Sets the number of TDI Stages to 64.
		128	Sets the number of TDI Stages to 128.
		192	Sets the number of TDI Stages to 192.
		256	Sets the number of TDI Stages to 256.

**Table 9.3 XML Parameters related to TDI Stages  
(VT-4K5X / VT-6K3.5X / VT-12K5X / VT-16K5X / VT-18K3.5X / VT-23K3.5X)**

The number of available TDI Stages for each camera model is as follows.

Camera Model	Available TDI Stage Values
VT-3K7X-E250A-32	32
VT-3K7X-H250A-128	32 / 64 / 96 / 128
VT-4K5X-E200A-64	64
VT-4K5X-H200A-256	64 / 128 / 192 / 256
VT-6K3.5X-E160A-64	64
VT-6K3.5X-H160A-256	64 / 128 / 192 / 256
VT-6K10X-E170-32	32
VT-6K10X-H170A-128	32 / 64 / 96 / 128
VT-9K7X-E120A-32	32
VT-9K7X-H120A-128	32 / 64 / 96 / 128
VT-9K7X-E250A-32	32
VT-9K7X-H250A-128	32 / 64 / 96 / 128
VT-12K5X-E100A-64	64
VT-12K5X-H100A-256	64 / 128 / 192 / 256
VT-12K5X-E200A-64	64
VT-12K5X-H200A-256	64 / 128 / 192 / 256
VT-16K5X-E140A-64	64
VT-16K5X-H140A-256	64 / 128 / 192 / 256
VT-18K3.5X-E80A-64	64
VT-18K3.5X-H80A-256	64 / 128 / 192 / 256
VT-18K3.5X-E140A-64	64
VT-18K3.5X-H140A-256	64 / 128 / 192 / 256
VT-23K3.5X-E100A-64	64
VT-23K3.5X-H100A-256	64 / 128 / 192 / 256

**Table 9.4 Available TDI Stage Values for each Camera Model**



VT-6K10X-H170 shows 64, 128, 192, 256 values to choose in the TDI Stages described the table above. However, each of those performs 32, 64, 96, 128 stages actually if chosen.

### 9.3 Scan Direction

In the **TDI** mode, the **Scan Direction** parameter is used to select the imaging sensor's scan direction. You need to set the **Scan Direction** parameter to **Forward** if the object being imaged will pass the bottom of the camera, and then pass the top of the camera. On the contrary, you need to set the **Scan Direction** parameter to **Reverse** if the object being imaged will pass the top of the camera, and then pass the bottom of the camera.

When you set the **Scan Direction** parameter to **Line 1**, you can also select the scan direction by injecting an externally generated electrical signal (Low = Forward, High = Reverse) into the pin 2 of the Control I/O receptacle on the camera.

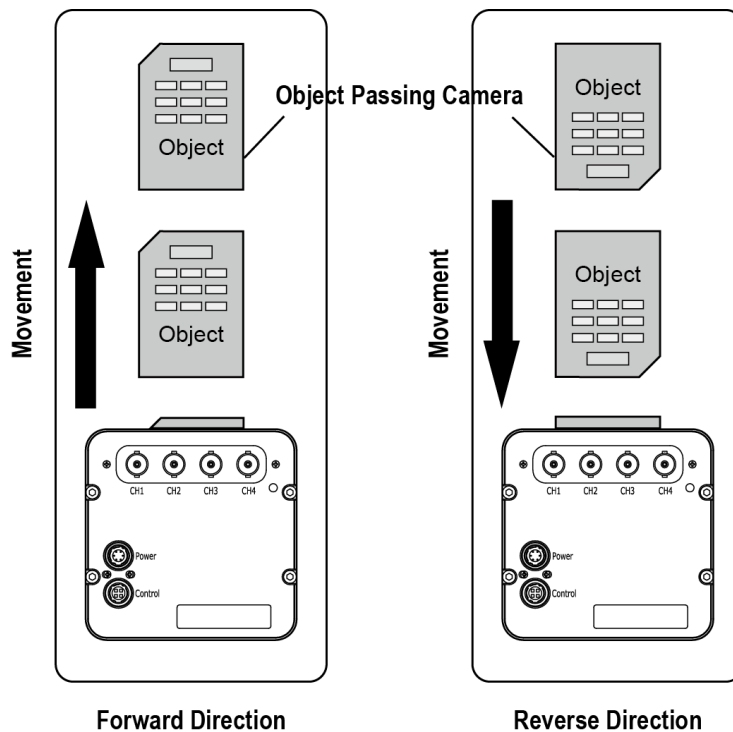


Figure 9.1 Scan Direction

XML Parameters		Value	Description
ImageFormatControl	Scan Direction	Forward	Scan images in the forward direction.
		Reverse	Scan images in the reverse direction.
		Line 1	Selects the scan direction using an external signal.

Table 9.5 XML Parameters related to Scan Direction

When you set the **Scan Direction** parameter to **Reverse** in the **Area** mode, you can acquire vertically flipped images.

## 9.4 Region of Interest

The Region of Interest (ROI) feature allows you to specify a portion of the sensor lines. During operation, only the pixel information from the specified portion of the lines are read out of the sensor and transmitted from the camera to the frame grabber.

The ROI is referenced to the left end of the sensor array. The location and size of the ROI is defined by declaring the **Offset X** and **Width** settings. For example, suppose that you set the Offset X parameter to 16 and the Width parameter to 256 as shown in the figure below. With these settings, the camera will read out and transmit pixel values for pixels 16 through 271.

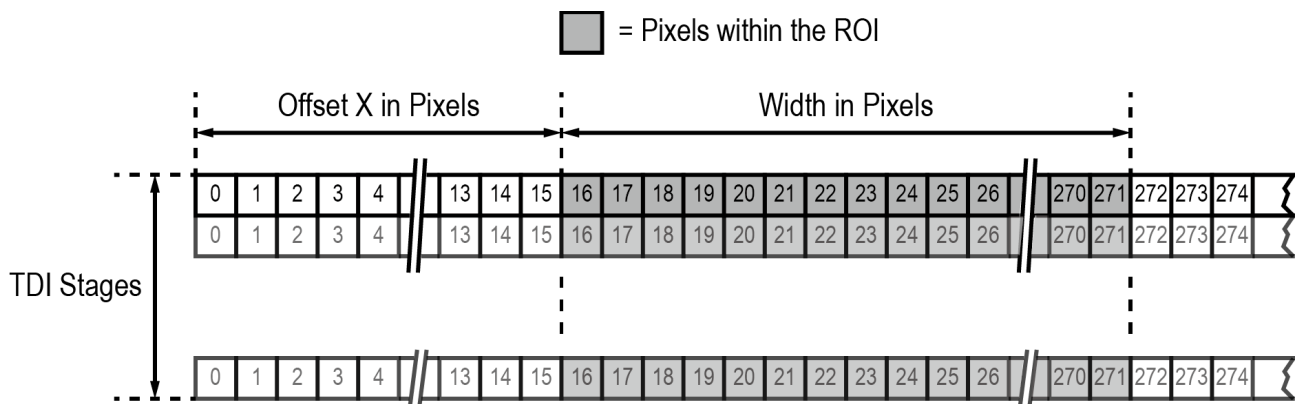


Figure 9.2 Region of Interest

### 9.4.1 Setting the ROI

By default, the ROI is set to use the full resolution of the camera's imaging sensor. You can change the size and location of the ROI by changing the Offset X and Width parameter values.

When you are setting the camera's region of interest, you must consider the following guidelines:

- The sum of the Offset X and Width setting values must not exceed the width of the camera's imaging sensor. For example, on the VT-12K5X camera, the sum of the Offset X and Width setting values must not exceed 12480.
- The Offset X setting value can be set to 0 and can be increased in increments of 16. The Width setting values must be a minimum of 256 and can be set to a multiple of 16.



Your CXP Frame Grabber may place additional restrictions on how the ROI location and size must be set. Refer to your CXP Frame Grabber User Manual for more information.

## 9.5 Binning

The Binning feature has the effects of increasing the scan speed and decreasing resolution by summing the values of the adjacent pixels and integrating them. This feature is particularly useful when you need to acquire line images with lower resolution. With the Binning feature, you can acquire lower resolution images without having to change the optics or lighting conditions.

### Horizontal Binning

If the Binning Horizontal parameter is set to  $\times 2$ , the sensitivity of the imaging sensor will be increased and the resolution of the imaging sensor will be decreased.

### Vertical Binning

If the Binning Vertical parameter is set to  $\times 2$ , the camera can achieve faster scan speed and the resolution of the imaging sensor will be decreased.

The XML parameters related to Binning are as follows.

XML Parameters		Value	Description
ImageFormatControl	BinningHorizontal	$\times 1$ , $\times 2$	Number of horizontal pixels to combine together
	BinningVertical	$\times 1$ , $\times 2$	Number of vertical pixels to combine together

**Table 9.6 XML Parameters related to Binning**



The Binning feature is only available on the VT-3K7X, VT-4K5X, VT-6K3.5X, VT-9K7X, VT-12K5X, VT-16K5X, VT-18K3.5X and VT-23K3.5X cameras.

## 9.6 Pixel Format

The camera processes image data in the unit of 12 bit internally. You can determine the format of these image data transmitted from the camera by using the **Pixel Format** parameter.

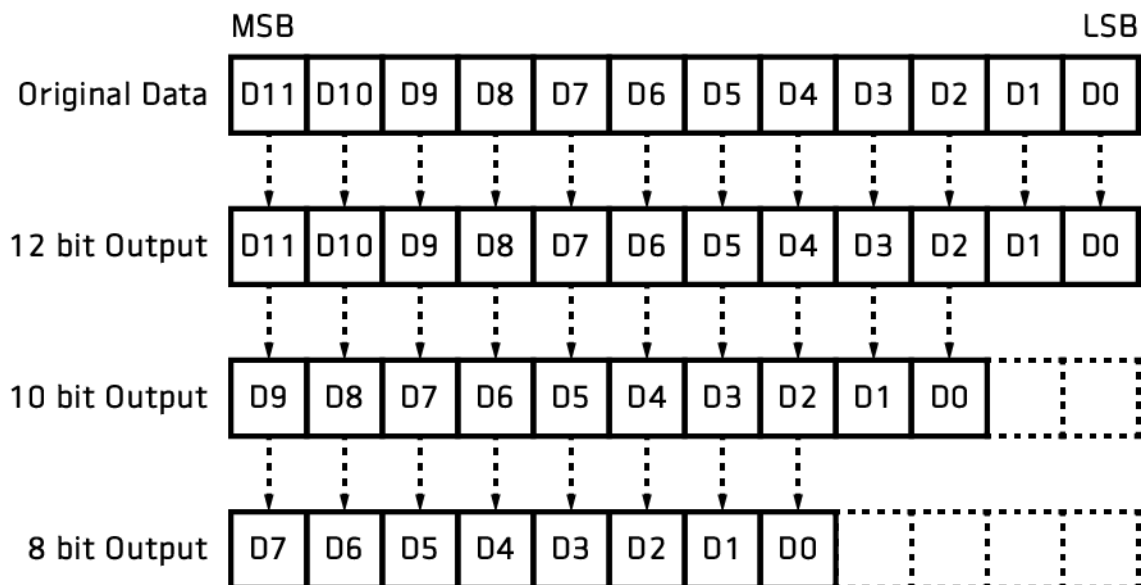


Figure 9.3 Data Format

The XML parameters related to Pixel Format are as follows.

XML Parameters		Value	Description
ImageFormatControl	PixelFormat	Mono8	Sets the pixel format to 8 bit.
		Mono10	Sets the pixel format to 10 bit.
		Mono12	Sets the pixel format to 12 bit.

Table 9.7 XML Parameter related to Pixel Format

## 9.7 Gain and Black Level

Increasing the **Gain** parameter increases all pixel values of the image. This results in a higher grey value output from the camera for a given amount of output from the image sensor.

1. Selects a Gain Control parameter as desired.
2. Set the Gain parameter to the desired value.

Adjusting the **Black Level** parameter will result in an offset to the pixel values output from the camera.

1. Set the Black Level parameter to the desired value.
2. The available setting range varies depending on the Pixel Format settings.

The XML parameters related to Gain and Black Level are as follows.

XML Parameters		Value	Description
AnalogControl	AnalogGain	×1, ×2, ×3, ×4	Sets an absolute analog gain value.
	DigitalGain	×1.0 ~ ×8.0	Sets an absolute digital gain value (0 dB ~ 18 dB).
	BlackLevel	-255 ~ 255	Sets an absolute physical black level value (@ 8 bits).

**Table 9.8 XML Parameters related to Gain and Black Level**



## 9.8 LUT

The Lookup Table (LUT) feature allows you to convert original image values to certain level values.

### Luminance

Since it is mapped one to one for each level value, 12 bit output can be connected to 12 bit input. The LUT is in the form of table that has 4096 entries between 0~4095 and VT camera provides a non-volatile space for LUT data storage. You can determine whether to apply LUT. For more information about how to download LUT to the camera, refer to [Appendix B](#).

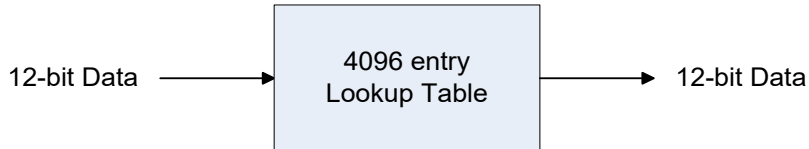


Figure 9.4 LUT Block

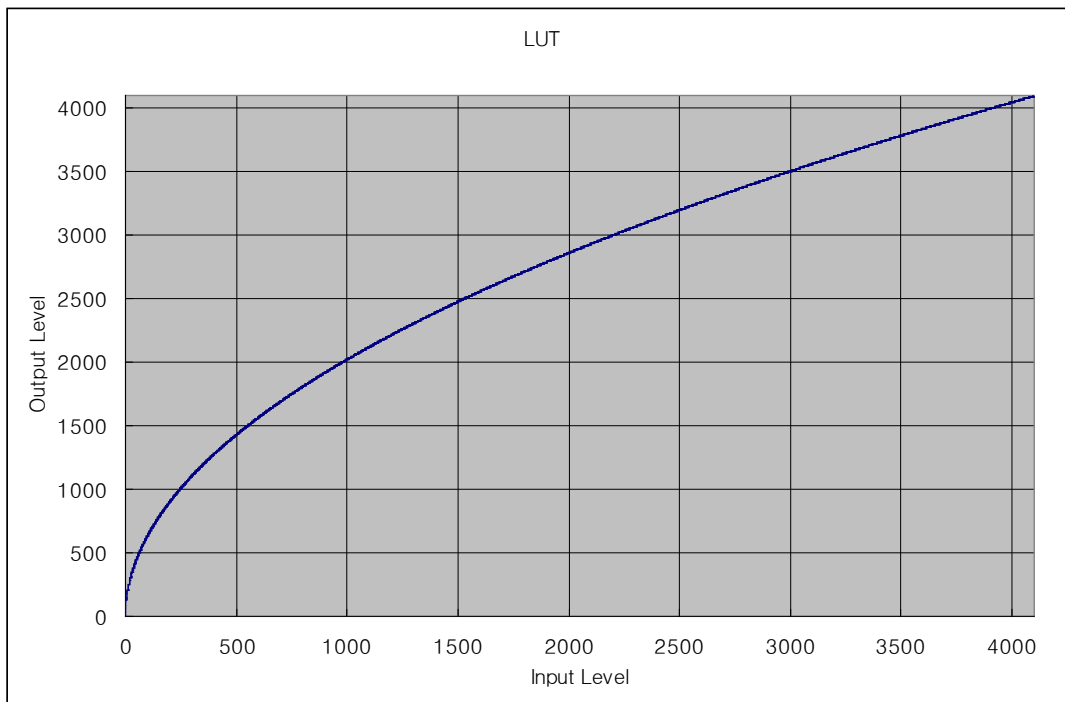


Figure 9.5 LUT at Gamma 0.5

XML parameters related to LUT are as follows.

XML Parameters		Value	Description
LUTControl	LUTSelector	Luminance	Luminance LUT
	LUTEnable	On	Activates the selected LUT.
		Off	Deactivates the selected LUT.
	LUTIndex	0 ~ 4095	Index of coefficient for verifying the LUT value.
	LUTValue	0 ~ 4095	Output value of the current LUT corresponding to the input value of LUT Index.
	LUTSave	-	Saves the current LUT data to the non-volatile memory.
	LUTLoad	-	Loads the LUT data from the non-volatile memory.

**Table 9.9 XML Parameters related to LUT**

## 9.9 Dark Signal Non-uniformity Correction

In theory, when a digital camera acquires images in complete darkness, all of the pixel values in the image should be near zero and they should be equal. In practice, however, slight variations in the performance of the pixels in the sensor will cause some variations in the pixel values output from the camera when the camera is acquiring in darkness. This variation is known as Dark Signal Non-uniformity (DSNU). VT CXP camera provides the DSNU Correction feature.

The XML parameters related to DSNU are as follows.

XML Parameters		Value	Description
DSNU	DSNUGenerateAll	-	Generates and saves the DSNU data for each Analog Gain setting value (×1, ×2, ×3, ×4).
	DSNUGenerate	-	Generates the DSNU data.
	DSNUSave	-	Saves the generated DSNU data in the non-volatile memory. <ul style="list-style-type: none"> <li>The generated data by executing the <b>DSNUGenerate</b> parameter are saved in the volatile memory so that the data are lost if the camera is reset or if power is turned off. To use the data after the camera is powered on or reset, save them in the non-volatile memory.</li> </ul>
	DSNULoad	-	Loads the DSNU data from the non-volatile memory into the volatile memory.

**Table 9.10 XML Parameters related to DSNU**

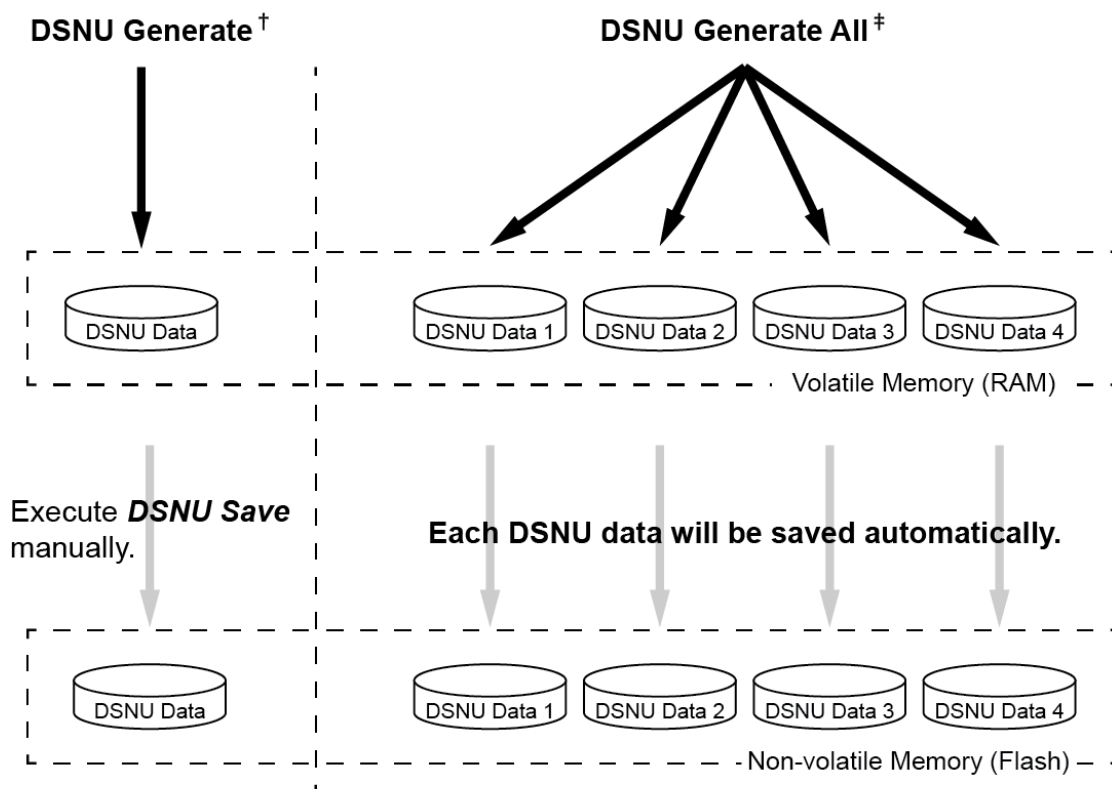
## 9.9.1 Generating and Saving User DSNU Correction Values

To generate and save user DSNU correction values, use the following procedure.



For optimum DSNU correction results, we recommend to generate DSNU data after the temperature of the camera housing has been stabilized.

1. The camera will use the entire sensor when generating DSNU correction values. Therefore, we recommend that you set the ROI setting to use the entire width of the sensor.
2. Ensure that the camera will be acquiring line images in complete darkness by covering the camera lens, closing the iris in the lens, or darkening the room.
3. Begin acquiring line images either by setting the camera for the Free-Run mode or by supplying external trigger signals to trigger line acquisitions.
4. Generate DSNU correction values.
  - Go to step 5 if you execute the **DSNU Generate** command to generate DSNU data.
  - Go to step 6 if you execute the **DSNU Generate All** command to generate DSNU data.
5. If you execute the **DSNU Generate** command,
  - a. Generates DSNU data according to the current Analog Gain setting value. The camera must acquire at least 1024 line images to create a set of DSNU correction values.
  - b. After completing 1024 line acquisitions, the generated DSNU correction values will be activated and saved in the camera's volatile memory.
  - c. To save the generated DSNU correction values in the camera's Flash (non-volatile) memory, execute the **DSNU Save** command. The previous DSNU values for the current Analog Gain setting value saved in the memory will be overwritten.
6. If you execute the **DSNU Generate All** command,
  - a. Generates the DSNU data for each Analog Gain setting value ( $\times 1$ ,  $\times 2$ ,  $\times 3$ ,  $\times 4$ ) and then executes the **DSNU Save** command automatically. The camera must acquire at least 4096 line images to create sets of DSNU correction values.
  - b. After completing 4096 line acquisitions, the generated DSNU correction values according to the current Analog Gain setting value will be activated.
7. If you change the Analog Gain setting value or want to load the existing values in the Flash memory, execute the **DSNU Load** command.



†. The camera generates **DSNU data** according to **the current Analog Gain setting**.

‡. The camera generates **four different DSNU data** according to **the Analog Gain setting values**.

Figure 9.6 Generating and Saving DSNU Correction Values

## 9.10 Photo Response Non-uniformity Correction

In theory, when a line scan camera acquires images with the camera viewing a uniform light-colored target in bright light, all of the pixel values in the image should be near the maximum grey value and they should be equal. In practice, however, slight variations in the performance of the pixels in the sensor, variations in the optics, and variations in the lighting will cause some variations in the pixel values output from the camera. This variation is known as Photo Response Non-uniformity (PRNU). VT CXP camera provides the PRNU Correction feature and five storage locations for PRNU correction values.

The XML parameters related to PRNU are as follows.

XML Parameters	Value	Description	
PRNU	PRNUMode	Off	Disables the PRNU Correction feature.
		On	Enables the PRNU Correction feature.
	PRNU Selector	0/1/2/3/4	Selects a location to save PRNU data to or load PRNU data from.
	TargetLevelAUTO	-	Select to set the PRNU Target Level automatically.
	PRNUTargetLevel	0 ~ 255	Sets the PRNU Target Level.
	PRNU Generate	-	Generates the PRNU data.
	PRNUSave	-	Saves the generated PRNU data in the non-volatile memory. <ul style="list-style-type: none"> <li>The generated data by executing the <b>PRNUGenerate</b> parameter are saved in the volatile memory so that the data are lost if the camera is reset or if power is turned off. To use the data after the camera is powered on or reset, save them in the non-volatile memory.</li> </ul>
	PRNULoad	-	Loads the PRNU data from the non-volatile memory into the volatile memory.

**Table 9.11 XML Parameters related to PRNU**

## 9.10.1 Generating and Saving User PRNU Correction Values

To generate and save user PRNU correction values, use the following procedure.



- We strongly recommend that you generate new PRNU correction values whenever you make a change to the optics or lighting or if you change the camera's line rate.
- For optimum PRNU correction results, we recommend to generate DSNU correction values first before generating PRNU correction values.

1. The camera will use the entire sensor when generating PRNU correction values. Therefore, we recommend that you set the ROI settings to use the entire width of the sensor.
2. Place a uniform white target in the field of view of the camera. Adjust the optics, lighting and line rate as you would for normal operation. We recommend that you make adjustments to achieve the digital output level in a range from 100 to 200 (Gain: 1.00 at 8 bit).
3. Begin acquiring line images either by setting the camera for the Free-Run mode or by supplying external trigger signals to trigger line acquisition.
4. Set the Target Level.
  - To set the Target Level automatically, select the **Target Level AUTO** check box.
  - To set the Target Level manually, deselect the **Target Level AUTO** check box and input the target level in a range from 0 to 255.
5. Execute the **PRNU Generate** command to generate PRNU correction values.
6. The camera must acquire at least 1024 line images to create a set of PRNU correction values.
7. After completing 1024 line acquisitions, the generated PRNU correction values will be activated and saved in the camera's volatile memory.
8. To save the generated PRNU correction values in the camera's Flash (non-volatile) memory, specify a location to save by using the **PRNU Selector** parameter and execute the **PRNU Save** command. The existing values in the memory will be overwritten.

To ignore the generated PRNU correction values and load the existing values in the Flash memory, specify a location to load from by using the **PRNU Selector** parameter and execute the **PRNU Load** command.

## 9.11 Reverse X

The Reverse X feature lets you flip the image horizontally. This feature is available in all operation modes.



Figure 9.7 Original Image



Figure 9.8 Reverse X Image

The XML parameter related to Reverse X is as follows.

XML Parameters		Value	Description
ImageFormatControl	Reverse X	-	Select to enable the Reverse X feature.

Table 9.12 XML Parameters related to Reverse X



## 9.12 CXP Link Configuration

VT CXP camera must be connected to a CXP Frame Grabber installed in your computer via CoaXPress interface. CoaXPress interface allows you to connect a camera to a CXP Frame Grabber by using simple coax cabling and allows up to 6.25 Gbps data rate per cable. Four channel VT CXP cameras support one master connection and up to three extension connections to configure a link. Two channel VT CXP cameras support one master connection and one extension connection to configure a link. In compliance with the CoaXPress standard, VT CXP camera includes an automatic link detection (Plug and Play) mechanism to correctly detect the camera to CXP Frame Grabber connections.

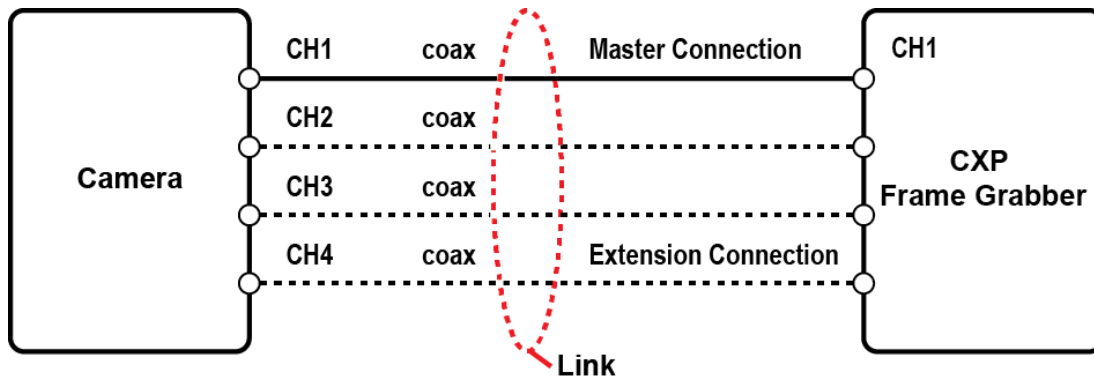


Figure 9.9 CXP Link Configuration

The XML parameters related to the link configuration between the camera and CXP Frame Grabber are located in the CoaXPress category under the Transport Layer Control as shown below.

XML Parameters		Value	Description
CoaXPress	CxpLinkConfiguration PreferredSwitch	CXP3_X1, X2, X4	Sets the <b>A</b> parameter value to CXP3_X1, X2, X4.
		CXP5_X1, X2, X4	Sets the <b>A</b> parameter value to CXP5_X1, X2, X4.
		CXP6_X1, X2, X4	Sets the <b>A</b> parameter value to CXP6_X1, X2, X4.
	CxpLinkConfiguration Preferred <sup>A</sup>	Read Only	Displays bit rate and the number of connections to be set for the link configuration between the camera and Host (Frame Grabber) while discovering devices.
	CXPLinkConfiguration	CXP3_X1, X2, X4 CXP5_X1, X2, X4 CXP6_X1, X2, X4	Forcefully sets bit rate and the number of connections for the link configuration. ex) CXP6_X4: Four connections running at a maximum of CXP6 speed (6.25 Gbps)

Table 9.13 XML Parameter related to CXP Link Configuration

### 9.13 CXP Multi-Link Configuration (M72/M95 based VT Series Only)

The CXP Multi-Link configuration of the VT CXP camera enables the transmission of data stream from a single camera to multiple frame grabbers or computers. When you configure the CXP Multi-Link, two channels of the camera are used to transmit image data to one CXP Frame Grabber and the other two channels are used to transmit the same image data to the other CXP Frame Grabber. In this case, the CH1 and CH2 channels serve as a 'Master Link' and the CH3 and CH4 channels serve as a 'Extension Link'. You can transmit image data, configure all camera features and apply trigger signals via the Master Link, however, you can only transmit image data via the Extension Link.

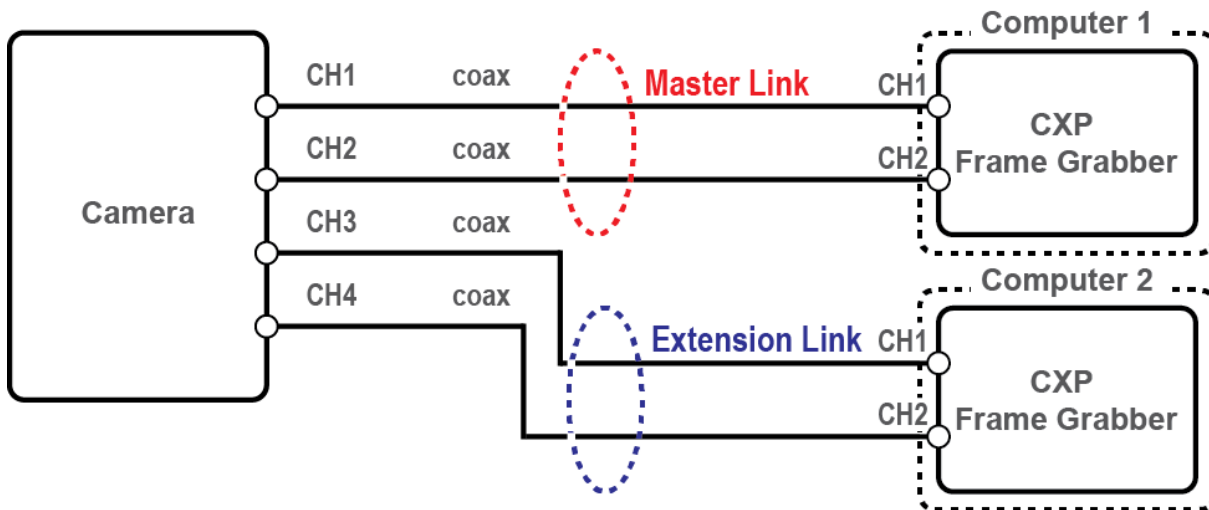


Figure 9.10 CXP Multi-Link Configuration

The XML parameter related to the multiple link configuration between the camera and CXP Frame Grabbers is located in the CoaXPress category under the Transport Layer Control as shown below.

XML Parameters		Value	Description
CoaXPress	CXPLinkCount	Link1	Configures a single link between one camera and one CXP Frame Grabber.
		Link2	Configures multi-link between one camera and two CXP Frame Grabbers.

Table 9.14 XML Parameter related to CXP Multi-Link Configuration



To use the Multi-Link function described above, the **CXP Link Counter** value needs to be set to Link2. Do one of two followings:

- Set the **CXPLinkCount** value to **Link2**. After that, execute **UserSetSave** and **UserSetLoad** sequentially.
- Set the **CXPLinkCount** value to **Link2**, after that, re-supply the power for a camera or execute **DeviceReset** to reset a camera.

## 9.14 Strobe Mode

VT CXP camera can output pulse signals through the control I/O receptacle. You can set a width of the pulse signal by using the **Strobe Mode** feature. This feature is useful when you need to supply source signals to the other devices such as a Strobe Controller.

The XML parameters related to Strobe Mode are as follows.

XML Parameters		Value	Description
DigitalIOControl	StrobeMode	Off	Disables the Strobe Mode feature.
		Timed	Outputs pulse signals according to the Strobe Duration setting values.
		PulseWidth	Outputs pulse signals of which the pulse width is equal to the trigger signals applied to the camera.
		On	Outputs continuous High signals.
	StrobeInverter	-	Select to invert the output signal.
	StrobeOutDelay	0 ~ 1000.00	Sets a delay to the current output signal in microseconds.
	StrobeDuration	0 ~ 1000.00	Sets a duration of pulse signal in microseconds when the Strobe Mode is set to Timed.

**Table 9.15 Strobe Mode**

## 9.15 Device User ID

You can input user defined information up to 16 bytes.

The XML parameter related to Device User ID is as follows.

XML Parameters		Description
DeviceControl	DeviceUserID	Inputs user defined information (16 byte).

**Table 9.16 XML Parameter related to Device User ID**

## 9.16 Device Reset

Reset the camera physically to power off and on. You must configure a link again because the camera will be released from the link between the camera and CXP Frame Grabber after reset.

The XML parameter related to Device Reset is as follows.

XML Parameters		Description
DeviceControl	DeviceReset	Resets the camera physically.

**Table 9.17 XML Parameter related to Device Reset**

## 9.17 Temperature Monitor

The camera has an embedded sensor chip to monitor the internal temperature.

The XML parameter related to Device Temperature is as follows.

XML Parameters		Description
DeviceControl	DeviceTemperature	Displays device temperature in Celsius.

**Table 9.18 XML Parameter related to Device Temperature**

## 9.18 Status LED

A red/green LED is installed on the back panel of the camera to inform the operation status of the camera. LED status and corresponding camera status are as follows.

Status LED	Descriptions
Steady Red	Camera is not initialized.
Slow Flashing Red	A CXP link is not configured.
Fast Flashing Orange	Camera is checking a CXP link configuration.
Steady Green	A CXP link is configured.
Fast Flashing Green	Camera is acquiring images.

**Table 9.19 Status LED**

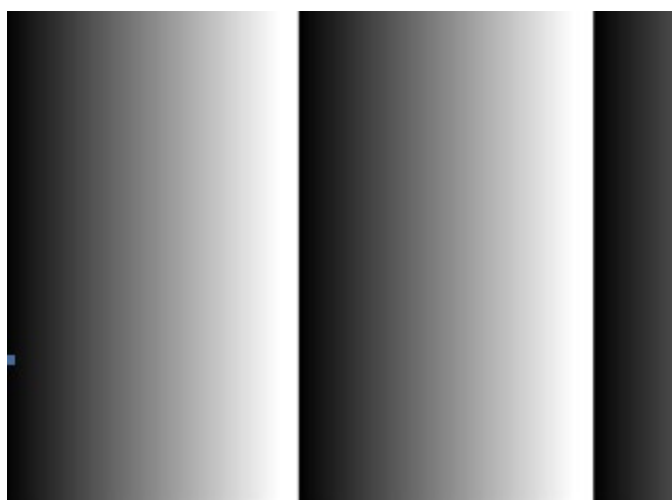
## 9.19 Test Pattern

To check normal operation of the camera, it can be set to output test patterns created inside, instead of image data from the imaging sensor. There are three types of test pattern; image with different value in horizontal direction (Grey Horizontal Ramp), image with different value in diagonal direction (Grey Diagonal Ramp), and moving image with different value in diagonal direction (Grey Diagonal Ramp Moving).

The XML parameter related to Test Pattern is as follows.

XML Parameters		Value	Description
ImageFormatControl	TestPattern	Off	Test Pattern Off
		GreyHorizontalRamp	Sets to Grey Horizontal Ramp.
		GreyDiagonalRamp	Sets to Grey Diagonal Ramp.
		GreyDiagonalRampMoving	Sets to Grey Diagonal Ramp Moving.

**Table 9.20 XML Parameter related to Test Pattern**



**Figure 9.11 Grey Horizontal Ramp**

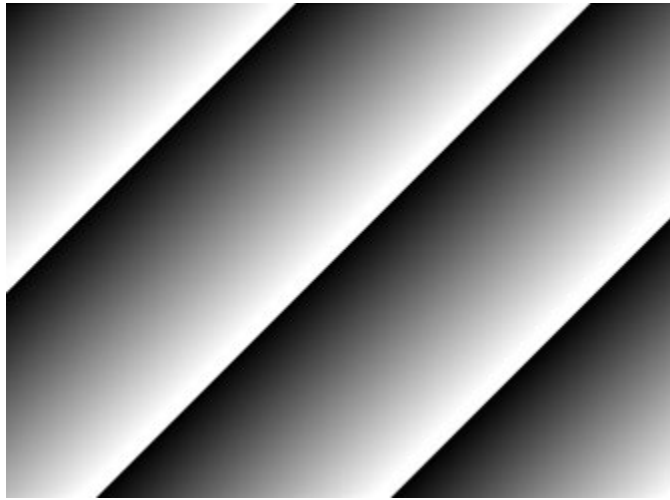


Figure 9.12 Grey Diagonal Ramp

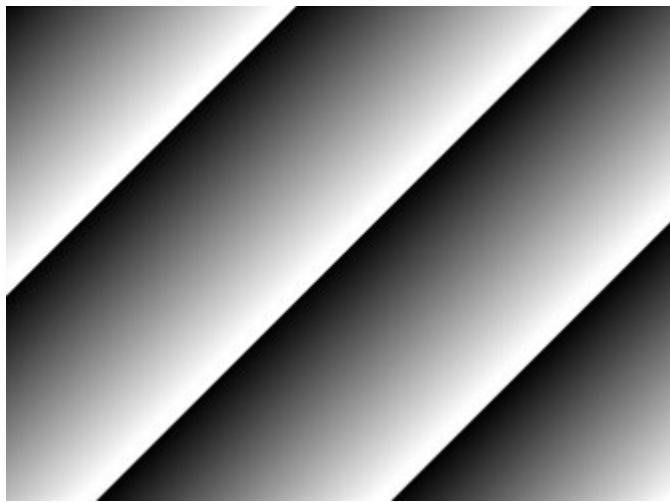


Figure 9.13 Grey Diagonal Ramp Moving



The test pattern may look different because the region of the test pattern may vary depending on the camera's resolution.

## 9.20 User Set Control

You can save the current camera settings to the camera's internal ROM. You can also load the camera settings from the camera's internal ROM. The camera provides two setups to save and three setups to load settings. The XML parameters related to User Set Control are as follows.

XML Parameters		Value	Description
UserSetControl	UserSetSelector	Default	Selects the Factory Default settings.
		UserSet1	Selects the User Set1 settings.
		UserSet2	Selects the User Set2 settings.
	UserSetLoad	-	Loads the User Set specified by User Set Selector to the camera.
	UserSetSave	-	Saves the current settings to the User Set specified by User Set Selector. <ul style="list-style-type: none"> <li>The Default is a Factory Default settings and allowed to load only.</li> </ul>
	UserSetDefault	Default	Applies the Factory Default settings when reset.
		UserSet1	Applies the User Set1 when reset.
		UserSet2	Applies the User Set2 when reset.

**Table 9.21 XML Parameters related to User Set Control**



## 9.20.1 Factory Default Setting Values

When you power the camera for the first time on, the factory default setting values will be loaded into the camera and the factory default setting values are as follows:

XML Parameters	Value
Operation Mode	TDI
Scan Direction	Forward
TDI Stages	Maximum Integration Stages
Trigger Mode	Off
Test Pattern	Off
Binning	×1
Pixel Format	Mono 8
PRNU Mode	On
DSNU Mode	On
CXP Link Configuration Preferred (4CH VT CXP Camera)	CXP5 × 4 CH or CXP6 × 4
CXP Link Configuration Preferred (2CH VT CXP Camera)	CXP5 × 2 CH or CXP6 × 2
Analog Gain	×1
Digital Gain	×1
Line Rate	80 kHz

**Table 9.22 Factory Default Setting Values**

## 9.21 Field Upgrade

The camera provides a feature to upgrade Firmware and FPGA logic through CoaXPress interface rather than disassemble the camera in the field. Refer to [Appendix A](#) for more details on how to upgrade.

## 10 Troubleshooting

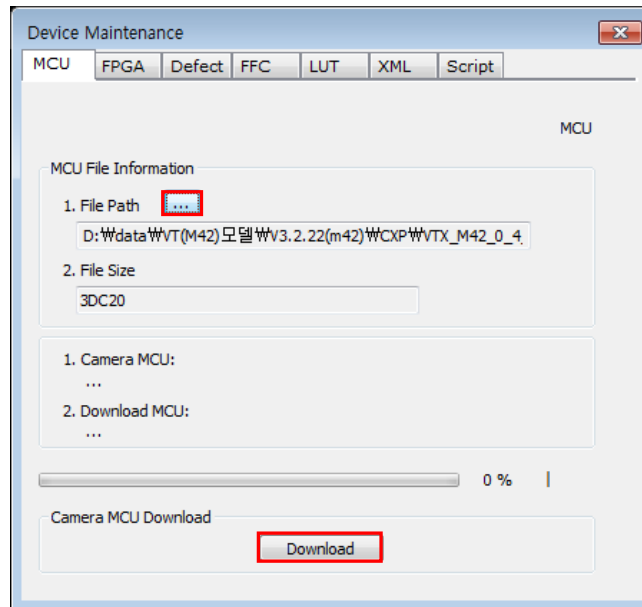
When you have a problem with a Vieworks camera, please check the followings:

- If no image is displayed on your computer,
  - Ensure that all cable connections are secure.
  - Ensure that the power supply is properly connected.
  - Ensure that trigger signals are applied correctly when you operate the camera with trigger signals.
- If images are not clear,
  - Ensure the camera lens or glass is clean.
  - Check the lens aperture is adjusted properly.
- If images are dark,
  - Ensure the camera lens is not blocked.
  - Check the line rate is set properly.
  - Check the aperture is opened properly.
  - Check the digital gain value is not set to small.
- If you identify abnormal operation or overheating sign,
  - Ensure the power supply is properly connected.
  - Stop using the camera when you notice smoke or abnormal overheating.
- If you have a problem using the Trigger Mode,
  - Ensure that the trigger related parameters on your CXP Frame Grabber are configured correctly when you set the Trigger Source parameter to CXPin.
  - Ensure that cable connections are secure when you operate the camera with external trigger signals.
- If there is a communication failure between the camera and user's computer,
  - Ensure coax cables are connected properly.
  - Ensure that you have configured a CXP Frame Grabber in your computer correctly and the camera is connected properly to the CXP Frame Grabber.

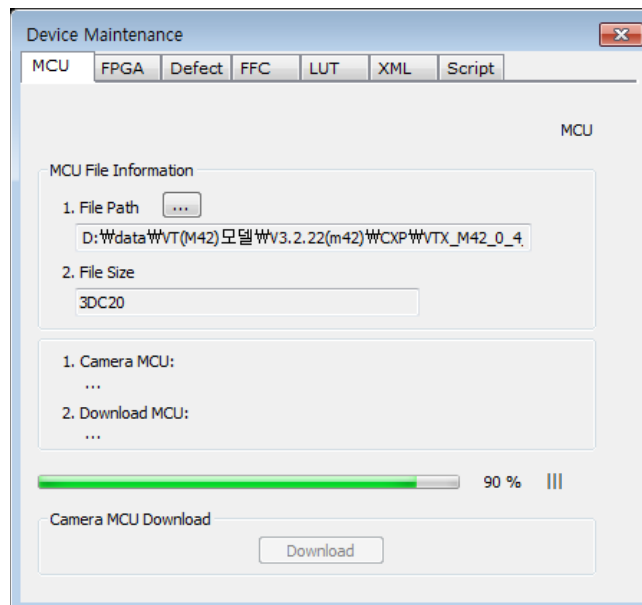
## Appendix A Field Upgrade

### A.1 MCU

1. Run Vieworks Imaging Solution 7.X and click the **Configure** button to display the window as shown below.
2. Select the **MCU** tab, click the File Path button, search and select the MCU upgrade file, and then click the **Download** button.



3. MCU upgrade file download starts and the downloading status is displayed at the bottom of the window.



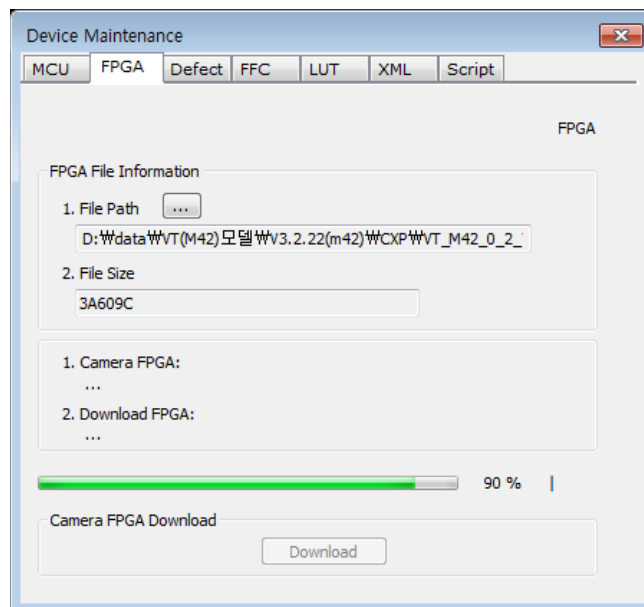
4. Once all the processes have been completed, turn the camera power off and turn it back on again.  
Check the Device Version parameter value in the Device Control category to confirm the version.

## A.2 FPGA

1. Run Vieworks Imaging Solution 7.X and click the **Configure** button to display the window as shown below.
2. Select the **FPGA** tab, click the File Path button, search and select the FPGA upgrade file, and then click the **Download** button.

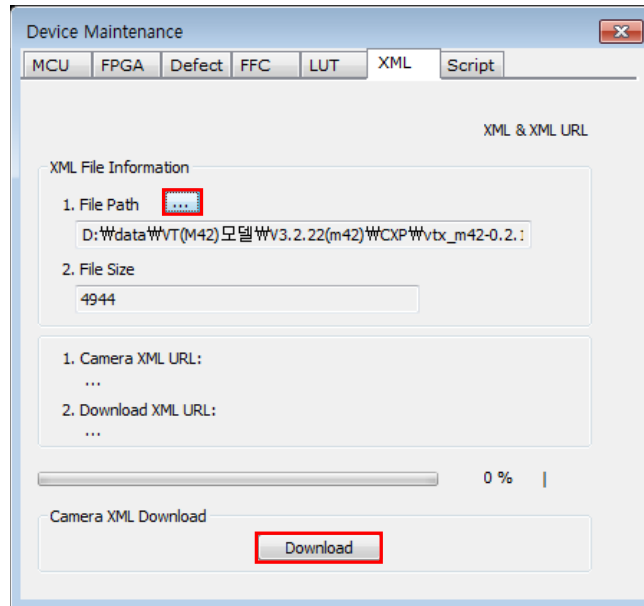


3. The subsequent processes are identical to those of MCU upgrade.

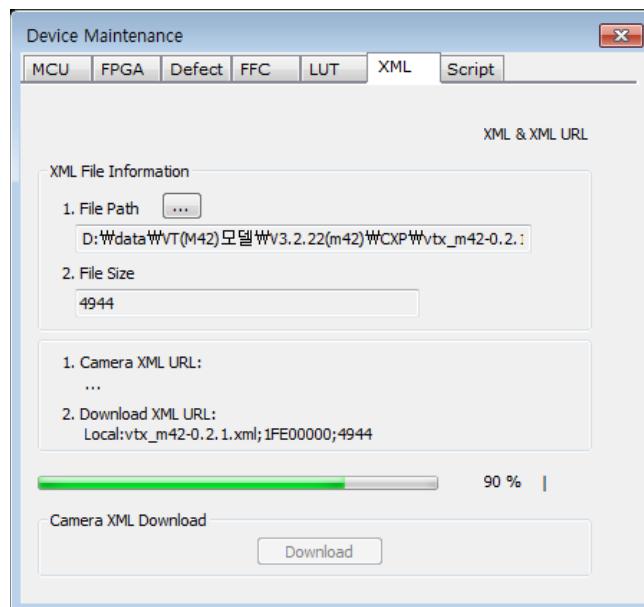


## A.3 XML

1. Run Vieworks Imaging Solution 7.X and click the **Configure** button to display the window as shown below.
2. Select the **XML** tab, click the File Path button, search and select the XML upgrade file, and then click the **Download** button.



3. The subsequent processes are identical to those of MCU upgrade.

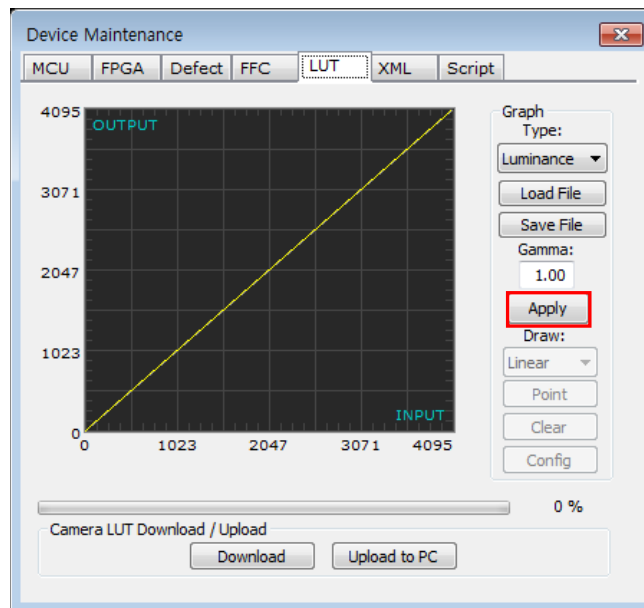


## Appendix B LUT Download

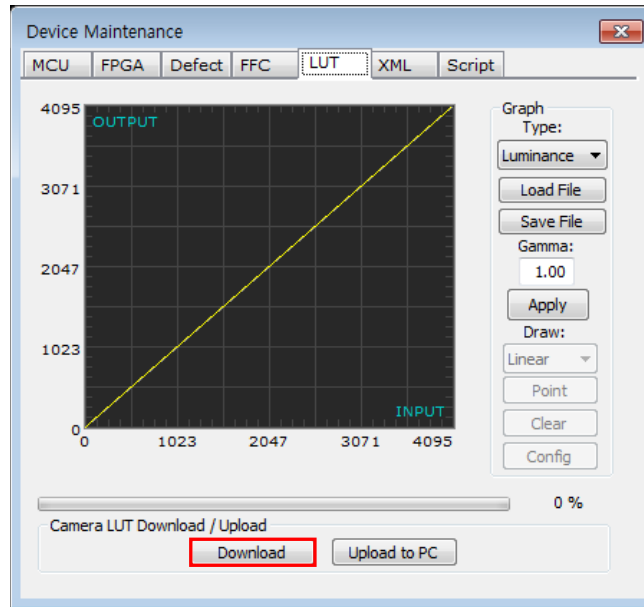
You can create LUT data in two different ways; by adjusting the gamma values on the gamma graph provided in the program and then downloading the data or by opening a CSV file (\*.csv) and then downloading the data.

### B.1 Gamma Graph Download

1. Run Vieworks Imaging Solution 7.X and click the **Configure** button to display the window as shown below. Select the **LUT** tab, and then select **Luminance** from the **Type** dropdown list.
2. Set a desired value in the **Gamma** input field and click the **Apply** button.



3. Click the **Download** button to download the gamma values to the camera.



4. After completing the download, click the **OK** button to close the confirmation.



## B.2 CSV File Download

1. Create the LUT table in Microsoft Excel format as shown in the left picture below and save as a CSV file (\*.csv). The picture in the right shows the created file opened in Notepad. Once the file has been created completely, change the .csv file extension to .lut. The following rules need to be applied when creating the file.

- Lines beginning with ':' or '--' are treated as notes.
- Based on the input values, make sure to record from 0 to 4095.

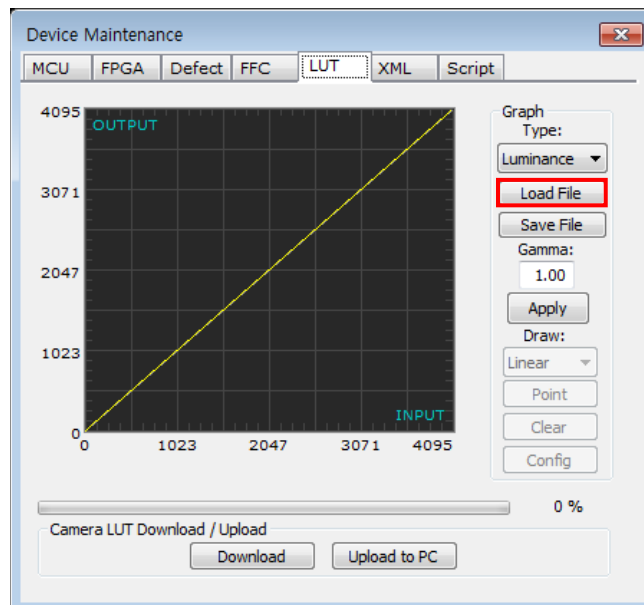
	A	B	C	D
1	:	comment line		
2	--	comment line		
3	--	input	output	
4		0	4095	
5		1	4094	
6		2	4093	
7		3	4092	
8		4	4091	
9	:	:		
10		4095	0	
11				
12				
13				

```

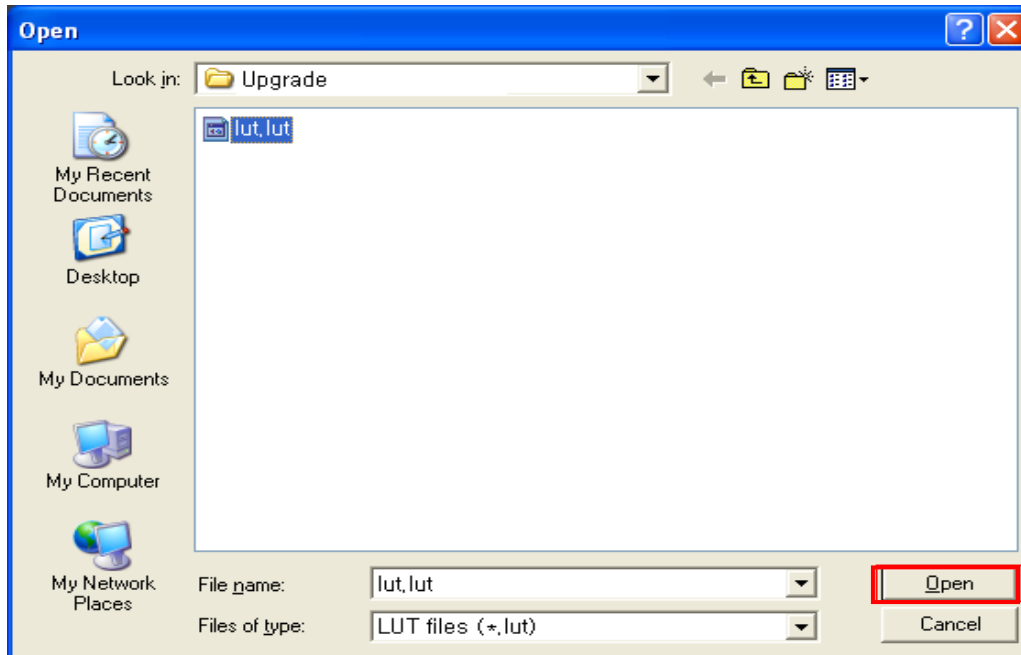
lut - Notepad
File Edit Format View Help
): comment line,
-- comment line,
-- input, output
0,4095
1,4094
2,4093
3,4092
4,4091
:::
4095,0

```

2. Run Vieworks Imaging Solution 7.X and click the **Configure** button to display the window as shown below. Select the **LUT** tab, select **Luminance** from the **Type** dropdown list, and then click the **Load File** button.



3. Search and select the created LUT file and click the **Open** button.



4. Click the **Download** button. After completing the download, click the **OK** button to close the confirmation.

## Appendix C Correction Control

The VT CXP cameras provide an additional feature to adjust DSNU or PRNU correction values after the DSNU or PRNU Correction feature is enabled. You can specify a pixel or region of the sensor and the pixel information from the specified portion will be adjusted according to the DSNU or PRNU coefficient value.

The XML parameters related to Correction Control are as follows.

XML Parameters	Value	Description	
Correction Control	StartX	-	X coordinate of a start pixel
	EndX	-	X coordinate of an end pixel
	DSNUCoef	-	Sets an additional DSNU correction value [Black Level value to be added to the specified region (DN, digital number)]
	DSNUCoefSet	-	Applies the additional DSNU correction value to the specified region.
	PRNUCoef	-	Sets an additional PRNU correction value (Gain value to be multiplied to the specified region)
	PRNUCoefSet	-	Applies the additional PRNU correction value to the specified region.
DSNU	DSNUSave	-	Saves the generated DSNU data in the non-volatile memory. <ul style="list-style-type: none"> <li>The generated data by executing the <b>DSNUCoefSet</b> parameter are saved in the volatile memory so that the data are lost if the camera is reset or if power is turned off. To use the data after the camera is powered on or reset, save them in the non-volatile memory.</li> </ul>
	DSNULoad	-	Loads the DSNU data from the non-volatile memory into the volatile memory.
PRNU	PRNUSelector	0/1/2/3/4	Selects a location to save PRNU data to or load PRNU data from.
	PRNUSave	-	Saves the generated PRNU data in the non-volatile memory. <ul style="list-style-type: none"> <li>The generated data by executing the <b>PRNUCoefSet</b> parameter are saved in the volatile memory so that the data are lost if the camera is reset or if power is turned off. To use the data after the camera is powered on or reset, save them in the non-volatile memory.</li> </ul>
	PRNULoad	-	Loads the PRNU data from the non-volatile memory into the volatile memory.

Table C.1 XML Parameters related to Correction Control

## C.1 Adjusting and Saving Additional DSNU Correction Value

For example, if you want to apply -2 black level from the 100<sup>th</sup> pixel to the 109<sup>th</sup> pixel, follow the procedures below.

1. Set the **Start X** parameter to 99.
2. Set the **End X** parameter to 108.
3. Set the **DSNU Coef** parameter to -2.
4. Execute the **DSNU Coef Set** command.
5. Execute the **DSNU Save** command to save the additional DSNU correction value in the camera's Flash (non-volatile) memory. In this case, the previous DSNU values for the current Analog Gain setting value saved in the memory will be overwritten. To ignore the adjusted DSNU correction values and load the existing values in the Flash memory, execute the **DSNU Load** command.

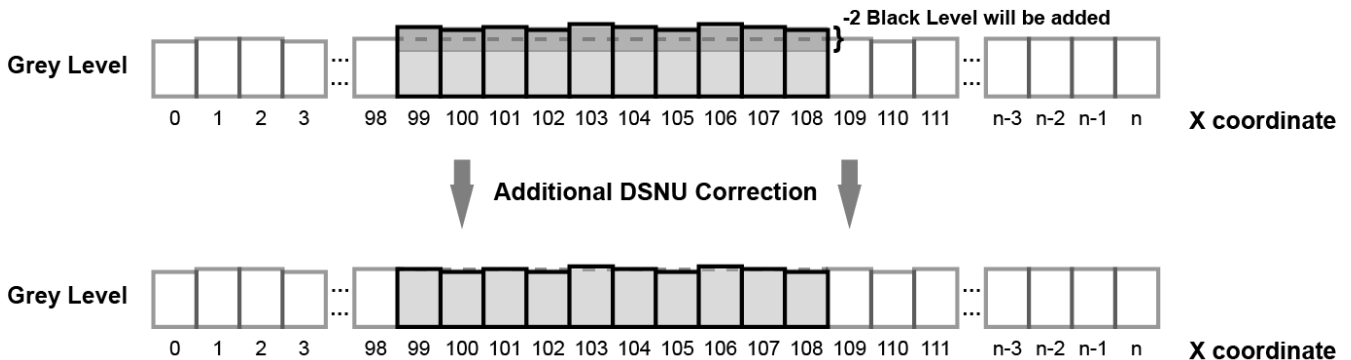


Figure C.1 Additional DSNU Correction

## C.2 Adjusting and Saving Additional PRNU Correction Value

For example, if you want to apply  $\times 1.1$  gain from the 100<sup>th</sup> pixel to the 109<sup>th</sup> pixel, follow the procedures below.

1. Set the **Start X** parameter to 99.
2. Set the **End X** parameter to 108.
3. Set the **PRNU Coef** parameter to 1.1.
4. Execute the **PRNU Coef Set** command.
5. Specify a location to save by using the **PRNU Selector** parameter and execute the **PRNU Save** command to save the additional PRNU correction value in the camera's Flash (non-volatile) memory. The existing values in the Flash memory will be overwritten. To ignore the adjusted PRNU correction values and load the existing values in the Flash memory, specify a location to load from by using the **PRNU Selector** parameter and execute the **PRNU Load** command.

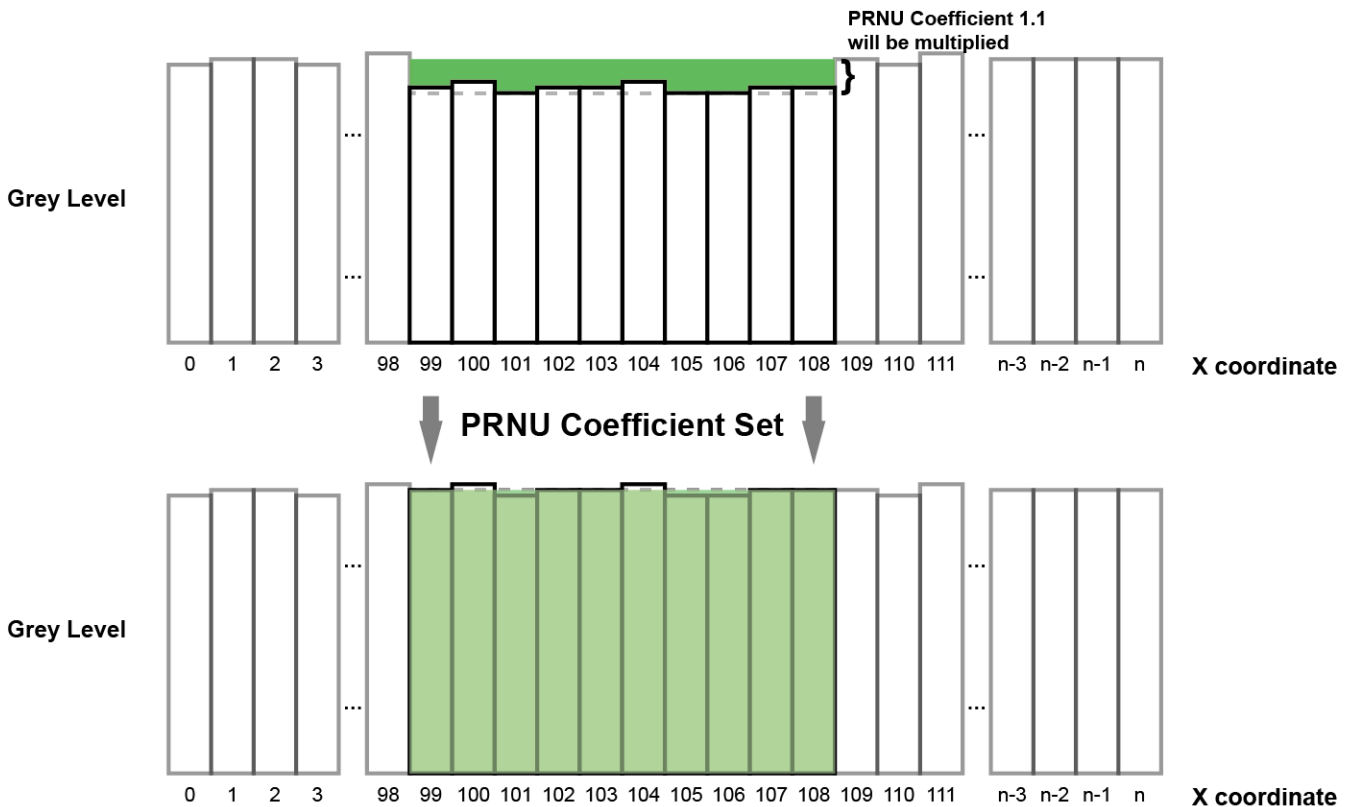
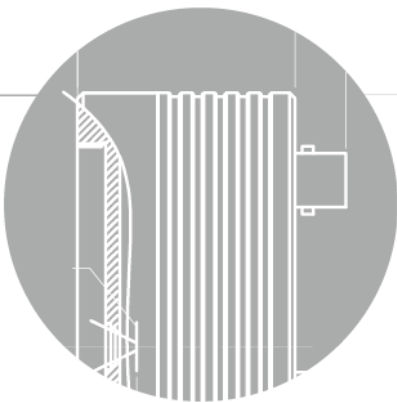
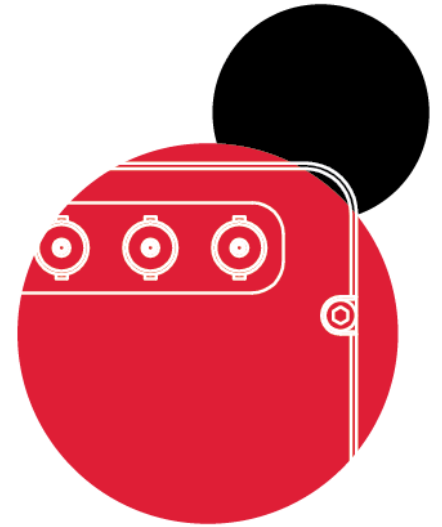
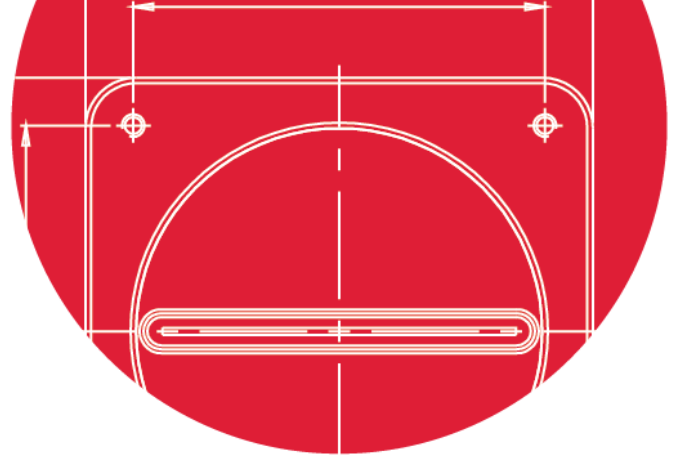


Figure C.2 Additional PRNU Correction



Before executing the **PRNU Coef Set** command, if you set the **PRNU Mode** parameter to **On**, you can determine the adjusted PRNU correction values in the acquired line images.



**Vieworks Co., Ltd.**

41-3, Burim-ro, 170beon-gil,  
Dongan-gu, Anyang-si, Gyeonggi-do  
14055 Republic of Korea

Tel: +82-70-7011-6161

Fax: +82-31-386-8631

<http://vision.vieworks.com>

[vision@vieworks.com](mailto:vision@vieworks.com)